

**INSTALLATION, OPERATING AND
SERVICE INSTRUCTIONS FOR**

APEX™

**CONDENSING HIGH EFFICIENCY
DIRECT VENT**

GAS - FIRED HOT WATER BOILER

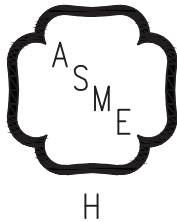

WARNING: Improper installation, adjustment, alteration, service or maintenance can cause property damage, injury, or loss of life. For assistance or additional information, consult a qualified installer, service agency or the gas supplier. This boiler requires a special venting system. Read these instructions carefully before installing.

IMPORTANT INFORMATION - READ CAREFULLY

NOTE: The equipment shall be installed in accordance with those installation regulations enforced in the area where the installation is to be made. These regulations shall be carefully followed in all cases. Authorities having jurisdiction shall be consulted before installations are made.

All wiring on boilers installed in the USA shall be made in accordance with the *National Electrical Code* and/or local regulations. All wiring on boilers installed in Canada shall be made in accordance with the *Canadian Electrical Code* and/or local regulations.

The City of New York requires a Licensed Master Plumber supervise the installation of this product.

The Massachusetts Board of Plumbers and Gas Fitters has approved the Apex™ Series boiler. See the Massachusetts Board of Plumbers and Gas Fitters website, http://license.reg.state.ma.us/pubLic/pl_products/pb_pre_form.asp for the latest Approval Code or ask your local Sales Representative.

The Commonwealth of Massachusetts requires this product to be installed by a Licensed Plumber or Gas Fitter.

The following terms are used throughout this manual to bring attention to the presence of hazards of various risk levels, or to important information concerning product life.



DANGER

Indicates an imminently hazardous situation which, if not avoided, will result in death, serious injury or substantial property damage.



CAUTION

Indicates a potentially hazardous situation which, if not avoided, may result in moderate or minor injury or property damage.



WARNING

Indicates a potentially hazardous situation which, if not avoided, could result in death, serious injury or substantial property damage.

NOTICE

Indicates special instructions on installation, operation, or maintenance which are important but not related to personal injury hazards.



WARNING

Explosion Hazard. DO NOT store or use gasoline or other flammable vapors or liquids in the vicinity of this or any other appliance.

If you smell gas vapors, DO NOT try to operate any appliance - DO NOT touch any electrical switch or use any phone in the building. Immediately, call the gas supplier from a remotely located phone. Follow the gas supplier's instructions or if the supplier is unavailable, contact the fire department.

Special Installation Requirements for Massachusetts

- A. For all sidewall horizontally vented gas fueled equipment installed in every dwelling, building or structure used in whole or in part for residential purposes and where the sidewall exhaust vent termination is less than seven (7) feet above grade, the following requirements shall be satisfied:
1. If there is no carbon monoxide detector with an alarm already installed in compliance with the most current edition of NFPA 720, NFPA 70 and the Massachusetts State Building Code in the residential unit served by the sidewall horizontally vented gas fueled equipment, a battery operated carbon monoxide detector with an alarm shall be installed in compliance with the most current edition of NFPA 720, NFPA 70 and the Massachusetts State Building Code.
 2. In addition to the above requirements, if there is not one already present, a carbon monoxide detector with an alarm and a battery back-up shall be installed and located in accordance with the installation requirements supplied with the detector on the floor level where the gas equipment is installed. The carbon monoxide detector with an alarm shall comply with 527 CMR, ANSI/UL 2034 Standards or CSA 6.19 and the most current edition of NFPA 720. In the event that the requirements of this subdivision can not be met at the time of the completion of the installation of the equipment, the installer shall have a period of thirty (30) days to comply with this requirement; provided, however, that during said thirty (30) day period, a battery operated carbon monoxide detector with an alarm shall be installed in compliance with the most current edition of NFPA 720, NFPA 70 and the Massachusetts State Building Code. In the event that the sidewall horizontally vented gas fueled equipment is installed in a crawl space or an attic, the carbon monoxide detector may be installed on the next adjacent habitable floor level. Such detector may be a battery operated carbon monoxide detector with an alarm and shall be installed in compliance with the most current edition of NFPA 720, NFPA 70 and the Massachusetts State Building Code.
 3. A metal or plastic identification plate shall be permanently mounted to the exterior of the building at a minimum height of eight (8) feet above grade directly in line with the exhaust vent terminal for the horizontally vented gas fueled heating appliance or equipment. The sign shall read, in print size no less than one-half (1/2) inch in size, **“GAS VENT DIRECTLY BELOW. KEEP CLEAR OF ALL OBSTRUCTIONS”**.
 4. A final inspection by the state or local gas inspector of the sidewall horizontally vented equipment shall not be performed until proof is provided that the state or local electrical inspector having jurisdiction has granted a permit for installation of carbon monoxide detectors and alarms as required above.
- B. EXEMPTIONS: The following equipment is exempt from 248 CMR 5.08(2)(a) 1 through 4:
1. The equipment listed in Chapter 10 entitled “Equipment Not Required To Be Vented” in the most current edition of NFPA 54 as adopted by the Board; and
 2. Product Approved sidewall horizontally vented gas fueled equipment installed in a room or structure separate from the dwelling, building or structure used in whole or in part for residential purposes.
- C. When the manufacturer of Product Approved sidewall horizontally vented gas equipment provides a venting system design or venting system components with the equipment, the instructions for installation of the equipment and the venting system shall include:
1. A complete parts list for the venting system design or venting system; and
 2. Detailed instructions for the installation of the venting system design or the venting system components.
- D. When the manufacturer of a Product Approved sidewall horizontally vented gas fueled equipment does not provide the parts for venting flue gases, but identifies “special venting systems”, the following shall be satisfied:
1. The referenced “special venting system” instructions shall be included with the appliance or equipment installation instructions; and
 2. The “special venting systems” shall be Product Approved by the Board, and the instructions for that system shall include a parts list and detailed installation instructions.
- E. A copy of all installation instructions for all Product Approved sidewall horizontally vented gas fueled equipment, all venting instructions, all parts lists for venting instructions, and/or all venting design instructions shall remain with the appliance or equipment at the completion of the installation.

TABLE OF CONTENTS

I.	Product Description, Specifications and Dimensional Data.....	5
II.	Unpacking Boiler.....	10
III.	Pre-Installation and Boiler Mounting.....	11
IV.	Venting.....	15
	A. General Guidelines.....	15
	B. CPVC/PVC Venting.....	20
	C. Polypropylene Venting.....	26
	D. Stainless Steel Venting.....	29
	E. Removing the Existing Boiler.....	32
	F. Multiple Boiler Installation Venting.....	33
V.	Condensate Disposal.....	35
VI.	Water Piping and Trim.....	37
VII.	Gas Piping	51
VIII.	Electrical	55
IX.	System Start-Up	69
X.	Operation.....	77
	A. Overview.....	77
	B. Supply Water Temperature Regulation.....	78
	C. Boiler Protection Features.....	79
	D. Multiple Boiler Control Sequencer.....	80
	E. Boiler Sequence of Operation.....	81
	1. Normal Operation.....	81
	2. Using the Display.....	82
	3. Status Screens.....	83
	4. Detail Screens.....	85
	5. Multiple Boiler Sequencer Screens.....	86
	F. Changing Adjustable Parameters.....	87
	1. Entering Adjust Mode.....	87
	2. Adjusting Parameters.....	87
XI.	Service and Maintenance	105
XII.	Troubleshooting.....	111
XIII.	Repair Parts	115
	Appendix A - Figures.....	128
	Appendix B - Tables.....	130
	Warranty.....	Back Page

I. Product Description, Specifications and Dimensional Data

Apex Series boilers are condensing high efficiency gas-fired direct vent hot water boilers designed for use in forced hot water space or space heating with indirect domestic hot water heating systems, where supply water temperature does not exceed 210°F. These boilers have special coil type stainless steel heat exchangers, constructed, tested and

stamped per Section IV ‘Heating Boilers’ of ASME Boiler and Pressure Vessel Code, which provide a maximum heat transfer and simultaneous protection against flue gas product corrosion. These boilers are not designed for use in gravity hot water space heating systems or systems containing significant amount of dissolved oxygen (swimming pool water heating, direct domestic hot water heating, etc.).

Table 1A: Specifications

Specification	Boiler Model				
	APX425	APX525	APX625	APX725	APX825
Altitude (ft. above sea level)	0-4500	0-4500	0-2000	0-2000	0-4500
Fuel	Shipped for Natural Gas, Field Converted for LP Gas		Shipped for Natural Gas or Shipped for LP Gas (no Field Conversion)		
Max. Allowable Water Temperature (°F)	210	210	210	210	210
Max. Allowable Working Pressure (psi)	160	160	160	160	160
Factory Supplied Safety Relief Valve (psi)*	50	50	60	60	60
Boiler Water Volume (gal.)	3.4	4.2	5.5	5.5	5.0
Heat Transfer Area (sq. ft.)	41.8	50.8	76.2	76.2	65.3
Approx. Shipping Weight (lb.)	304	350	455	455	430

* Optional 80 psi and 100 psi safety relief valves are available for all models.

Table 1B: Dimensions (See Figures 1A, 1B, 1C and 1D)

Dimension	Boiler Model				
	APX425	APX525	APX625	APX725	APX825
A - Inch (mm)	28-7/8 (734)	44-7/8 (1140)	50-1/4 (1276)	50-1/4 (1276)	54-9/16 (1384)
B - Inch (mm)	6-3/16 (157)	22-1/8 (562)	N/A	N/A	28-3/8 (724)
C - Inch (mm)	13-1/16 (332)	29 (737)	24 (610)	24 (610)	34-1/4 (876)
D - Inch (mm)	23-3/4 (602)	39-11/16 (1008)	38-7/8 (987)	38-7/8 (987)	48-1/16 (1226)
E - Inch (mm)	15-13/16 (402)	29-3/8 (752)	31-5/8 (803)	31-5/8 (803)	33-13/16 (864)
Gas Inlet F (FPT)	3/4"	3/4"	1"	1"	1"
Return G	1-1/2" (FPT)		2" (MPT)	2" (MPT)	2" (MPT)
Supply H	1-1/2" (FPT)		2" (MPT)	2" (MPT)	2" (MPT)
Condensate Drain J	Factory Provided Socket End Compression Pipe Joining Clamp for 3/4" Schedule 40 PVC Pipe				
Boiler Two-Pipe CPVC/PVC Vent Connector (Figures 1A, 1B, 1C and 1D) - Inch	4 x 4		6 x 6	6 x 6	6 x 6

6 I. Product Description, Specifications and Dimensional Data (continued)

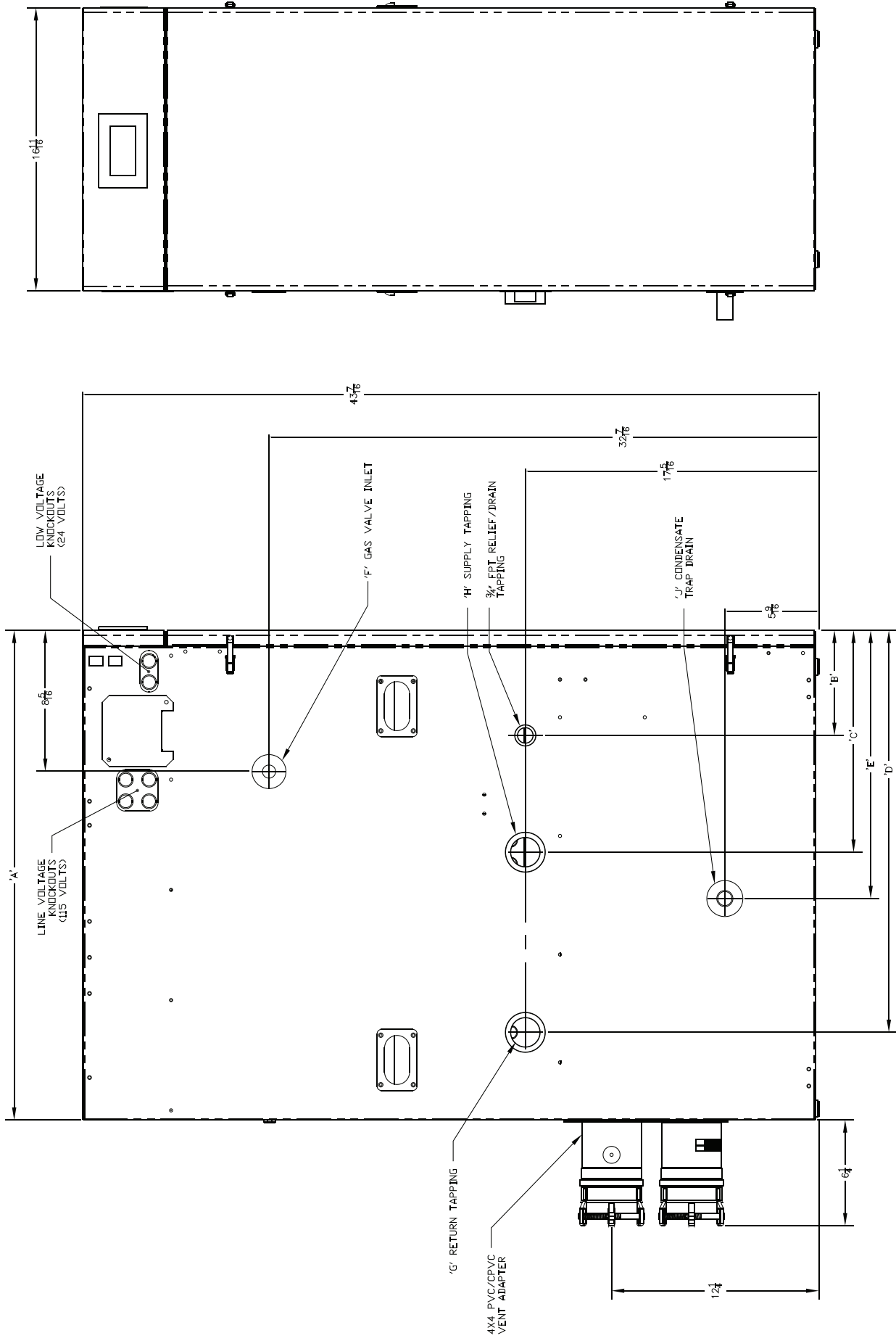

Figure 1A: Apex - Model APX425

I. Product Description, Specifications and Dimensional Data (continued)

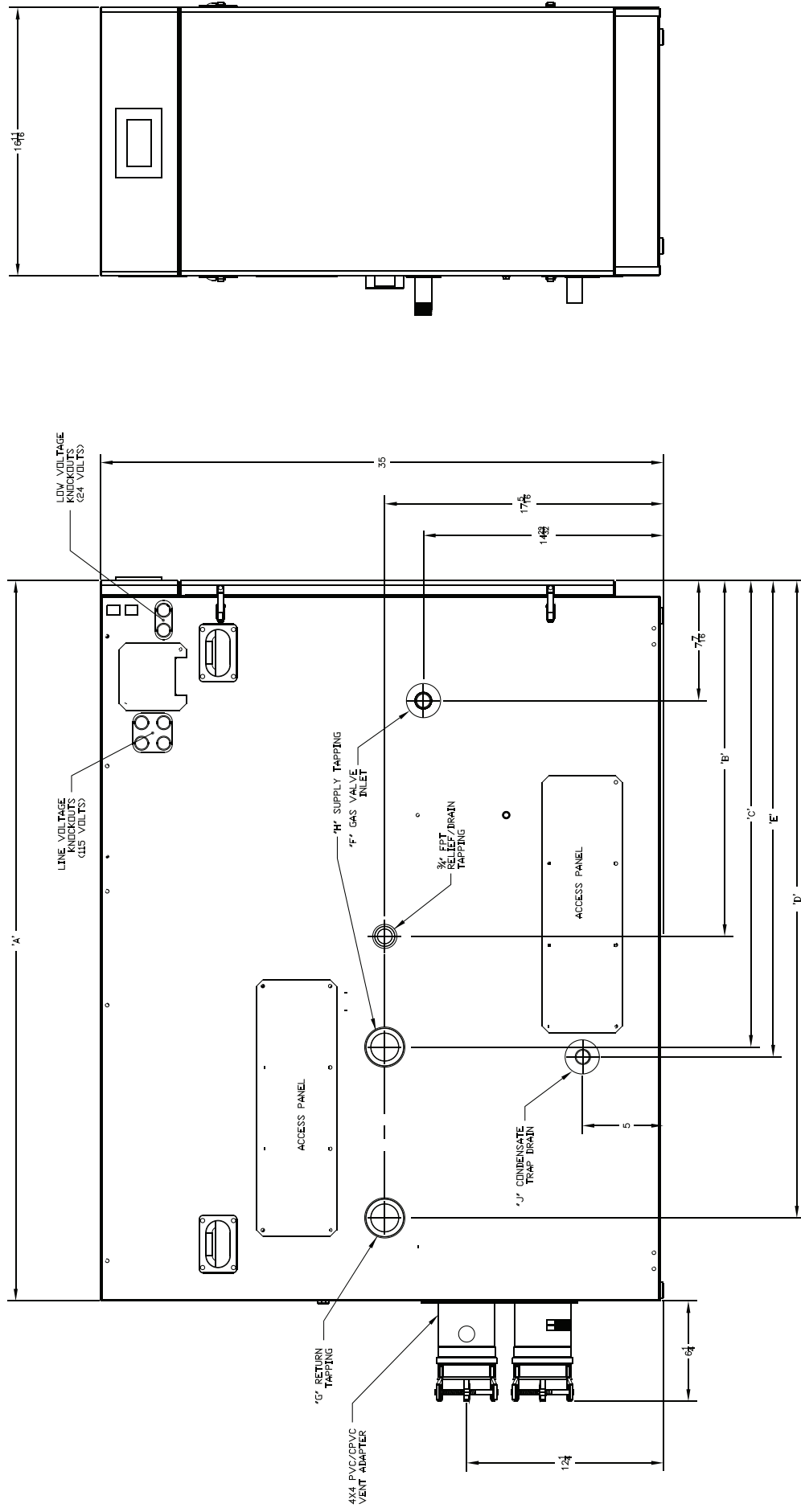

Figure 1B: Apex - Model APX525

∞ I. Product Description, Specifications and Dimensional Data (continued)

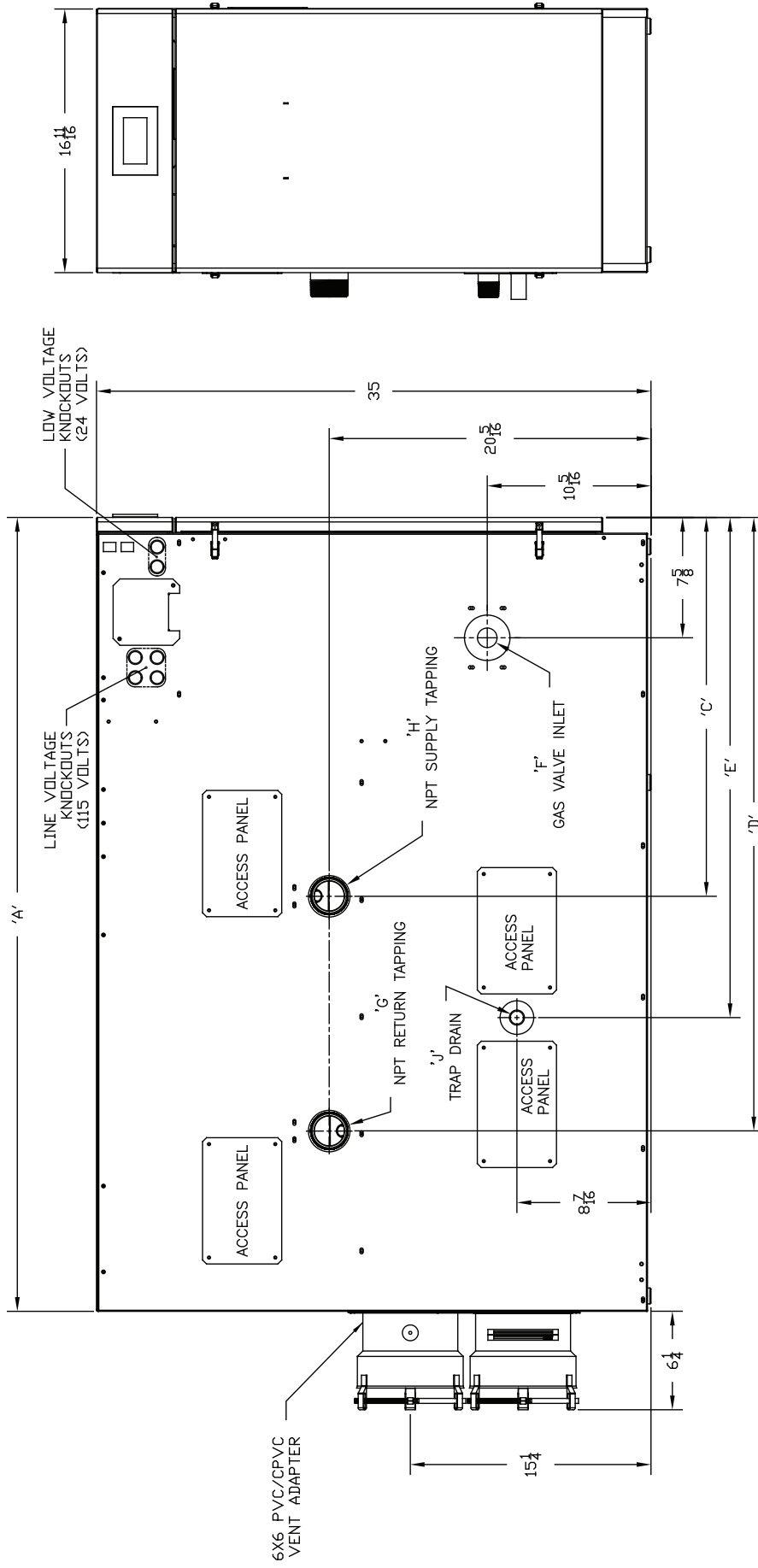

Figure 1C: Apex - Models APX625 and APX725

I. Product Description, Specifications and Dimensional Data (continued)

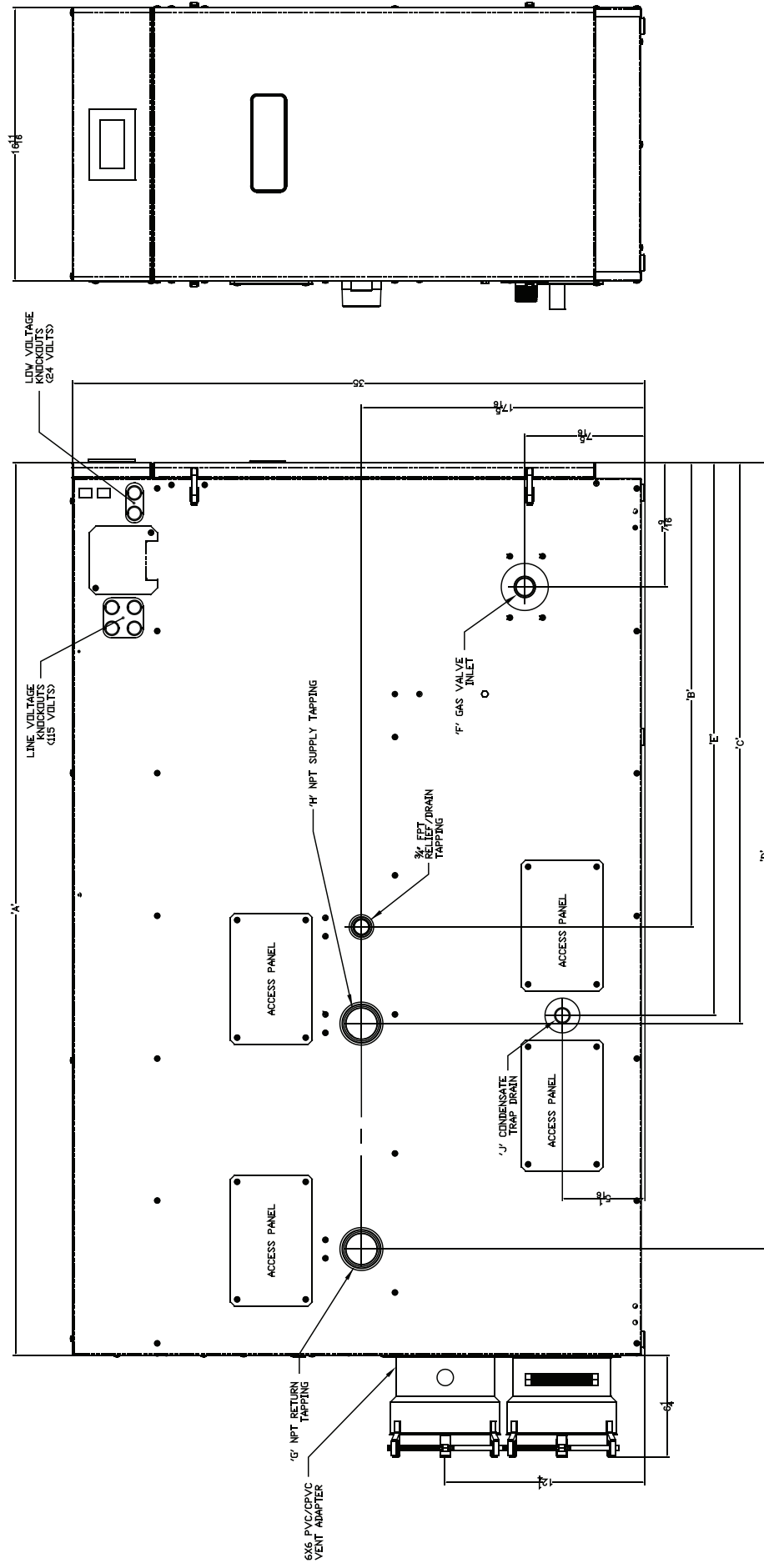



Figure 1D: Apex - Model APX825

I. Product Description, Specifications and Dimensional Data (continued)

Table 2: Ratings

Apex Series Gas-Fired Boilers						
						
Model Number	Input (MBH)		Gross Output (MBH)	Net Ratings Water ¹ (MBH)	Thermal Efficiency (%)	Combustion Efficiency (%)
	Min.	Max.				
APX425	80	399	375	326	94.1	94.5
APX525	100	500	475	413	95.0	95.0
APX625	125	625	594	517	95.0	96.0
APX725	145	725	689	599	95.0	95.0
APX825	160	800	760	661	95.0	93.0

Ratings shown are for installations at sea level and elevations up to 2000 ft. For elevations above 2000 ft., the boiler will naturally derate by 2.5% for each 1000 ft. above sea level.

¹ Net AHRI Water Ratings based on allowance of 1.15. Consult manufacturer before selecting boiler for installations having unusual piping and pickup requirements, such as intermittent system operation, extensive piping systems, etc.

II. Unpacking Boiler

NOTICE

Do not drop boiler.

- A. Move boiler** to approximate installed position.
- B. Remove all** crate fasteners.
- C. Lift and remove** outside container.
- D. Remove boiler** from cardboard positioning sleeve on shipping skid.
- E. Move boiler** to its permanent location.

III. Pre-Installation and Boiler Mounting



WARNING

Explosion Hazard. Asphyxiation Hazard. Electrical Shock Hazard. Installation of this boiler should be undertaken only by trained and skilled personnel from a qualified service agency. Follow these instructions exactly. Improper installation, adjustment, service, or maintenance can cause property damage, personal injury or loss of life.

NOTICE

Due to the low water content of the boiler, mis-sizing of the boiler with regard to the heating system load will result in excessive boiler cycling and accelerated component failure. Thermal Solutions DOES NOT warrant failures caused by mis-sized boiler applications. DO NOT oversize the boiler to the system. Multiple boiler installations greatly reduce the likelihood of boiler oversizing.



WARNING

Asphyxiation Hazard.
Models APX425 and APX525:
Apply supplied dielectric grease to gasket inside vent section of two-pipe vent connector. Failure to apply the grease could result in flue gas leaks from gasket rupture during vent pipe installation or gasket deterioration due to condensate exposure.

- A. Installation must conform** to the requirements of the authority having jurisdiction in or, in the absence of such requirements, to the *National Fuel Gas Code*, ANSI Z223.1/NFPA 54, and/or *Natural Gas and Propane Installation Code*, CAN/CSA B149.1. Where required by the authority having jurisdiction, the installation must conform to the *Standard for Controls and Safety Devices for Automatically Fired Boilers*, ANSI/ASME CSD-1.
- B. Boiler is certified** for installation on combustible flooring. Do not install boiler on carpeting.
- C. Provide clearance** between boiler jacket and combustible material in accordance with local fire ordinance. Refer to Figure 2 for minimum listed clearances from combustible material. Recommended service clearance is 24 in. (610 mm) from left side, front, top and rear of the boiler. Recommended front clearance may be reduced to the combustible material clearance providing:

1. Access to boiler front is provided through a door or removable front access panel.
2. Access is provided to the condensate trap located underneath the heat exchanger.
3. Access is provided to thermal link located at boiler rear.

- D. Protect gas ignition system components** from water (dripping, spraying, rain, etc.) during boiler operation and service (circulator replacement, condensate trap, control replacement, etc.).
- E. Provide combustion and ventilation air** in accordance with applicable provisions of local building codes, or: USA - *National Fuel Gas Code*, ANSI Z223.1/NFPA 54, Air for Combustion and Ventilation; Canada - *Natural Gas and Propane Installation Code*, CAN/CSA-B149.1, Venting Systems and Air Supply for Appliances.



WARNING

Asphyxiation Hazard. Adequate combustion and ventilation air must be provided to assure proper combustion. Install combustion air intake per Section IV "Venting".

- F. The boiler should be located** so as to minimize the length of the vent system. The combustion air piping must terminate where outdoor air is available for combustion and away from areas that may contaminate combustion air. In particular, avoid areas near chemical products containing chlorines, chlorofluorocarbons, paint removers, cleaning solvents and detergents. Avoid areas containing saw dust, loose insulation fibers, dry wall dust etc.

NOTICE

Avoid operating this boiler in an environment where sawdust, loose insulation fibers, dry wall dust, etc. are present. If boiler is operated under these conditions, the burner interior and ports must be cleaned and inspected daily to insure proper operation.

G. General.

1. Apex boilers are intended for installations in an area with a floor drain, or in a suitable drain pan to prevent any leaks or safety relief valve discharge resulting in property damage.
2. Apex boilers are not intended to support external piping and venting. All external piping and venting must be supported independently of the boiler.
3. Apex boilers must be installed level to prevent condensate from backing up inside the boiler.

III. Pre-Installation and Boiler Mounting G. General (continued)

4. Boiler Installation:

- For basement installation provide a solid level base such as concrete where floor is not level or where water may be encountered on the floor around boiler. Floor must be able to support weight of boiler, water and all additional system components.
- Boiler must be level to prevent condensate from backing up inside the boiler.
- Provide adequate space for condensate piping or a condensate pump if required.

* Note:

When boiler is vented vertically, the minimum clearance from the rear of the jacket is increased to 18 in. (460 mm) with a short radius 90° elbow provided in order to provide adequate space at boiler rear for installation of vent and air intake piping and service access.

Boiler Clearances to Combustible (and Non-Combustible) Material:

Models APX425 and APX525:

These boilers are listed for closet installation with the following minimum clearances – Top = 1 in. (25 mm), Front = 1 in. (25 mm), Left Side = 10 in. (250 mm), Right Side = 2 in. (50 mm), Rear = *6 in. (150 mm)

Models APX625, APX725 and APX825:

These boilers are listed for alcove installation with the following minimum clearances – Top = 1 in. (25 mm), Front = Open, Left Side = 10 in. (250 mm), Right Side = 2 in. (50 mm), Rear = *6 in. (150 mm)

Boiler Service Clearances – Applicable to all Boiler Models:

Top = 24 in. (610 mm), Front = 24 in. (610 mm), Left Side = 24 in. (610 mm), Right Side = 24 in. (610 mm), Rear = 24 in. (610 mm)

The above clearances are recommended for service access but may be reduced to the Combustible Material Clearances provided:

- The boiler front is accessible through a door.
- Access is provided to the condensate trap located on the left side of boiler.
- Access is provided to thermal link located at the boiler rear.

Listed Direct Vent System	Vent Pipe Material	Vent Pipe Direction	Enclosure	Vent Pipe Nominal Diameter	Minimum Clearance to Combustible Material
<u>Factory Standard</u> Two-Pipe CPVC/PVC Vent and PVC Combustion Air Intake	* CPVC/PVC	Vertical or Horizontal	Unenclosed at all Sides	4 in. (100 mm) or 6 in. (150 mm)	1 in. (25 mm)
<u>Available Optional</u> Two-Pipe Rigid Polypropylene Vent (or, Flexible Polypropylene Liner for Vertical Venting only) and Rigid Polypropylene or PVC Combustion Air Intake	Pipe Rigid Polypropylene Vent (or, Flexible Polypropylene Liner for Vertical Venting only)			4 in. (100 mm) or 6 in. (150 mm) or 160 mm	1 in. (25 mm)
<u>Available Optional</u> Two-Pipe Stainless Steel Vent and Galvanized Steel or PVC Combustion Air Intake	Stainless Steel			4 in. (100 mm) or 6 in. (150 mm)	1 in. (25 mm)

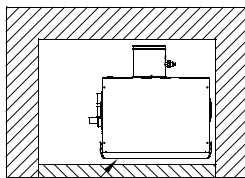

Removable Front Access Panel
Top View

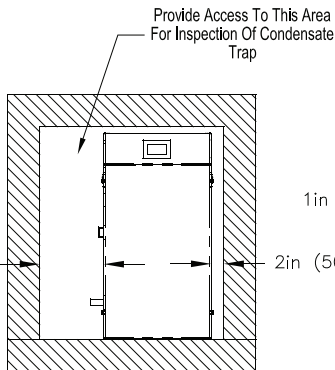

Front View

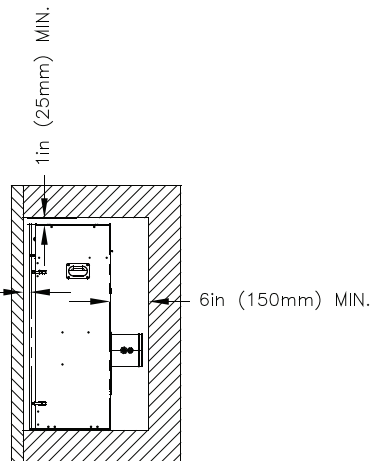

Right View

Figure 2: Clearances To Combustible and Non-combustible Material

III. Pre-Installation and Boiler Mounting H. Boiler Stacking (continued)

H. Boiler Stacking

1. For installations with unusually high space heating and/or domestic hot water heating loads, where employing 2 Apex boilers will offer the benefits of greater operational efficiency, floor space savings and boiler redundancy, Apex boilers may be installed stacked maximum one boiler on top of another. Refer to Table 3 “Apex Boiler Model Stacking Combinations” for details.

Table 3: Apex Boiler Model Stacking Combinations

Bottom Boiler Model	Top Boiler Model
APX425	APX425
APX525	APX425 or APX525
APX625	APX425, APX525 or APX625
APX725	APX425, APX525, APX625 or APX725
APX825	APX425, APX525, APX625, APX725 or APX825

2. To field assemble individual Apex boilers into a stackable configuration, use the steps below:
 - a. Position the bottom boiler first. Refer to Sections II “Unpacking Boiler” and III “Pre-Installation & Boiler Mounting” of the manual for details. **Always position higher input boiler model as bottom boiler.**
 - b. Each Apex boiler is factory packaged with 2 stacking boiler attachment brackets (P/N 101679-01) and the bracket mounting hardware [six (6) self-drilling hex washer head plated #8 x 1/2” long screws, P/N 80860743]. Locate and remove the brackets and the hardware. The stacking boiler attachment bracket has three 7/32” diameter holes punched in a triangular pattern. See Figure 3 “Stacking Boiler Attachment Bracket Placement”.
 - c. Apex boiler left and right side panels have a series of dimples at panel top and bottom. These dimples are positioning dimples for stacking boiler attachment bracket mounting screws. Side panel bottom positioning dimples are evenly spaced from boiler front and back, while side panel top positioning dimples follow specific pattern to compensate for Apex boiler model variable depth.
 - d. Position the upper boiler on top of the bottom boiler and align boiler front doors and sides flush with each other.
 - Place first stacking boiler attachment bracket onto the upper boiler left side panel, at the panel lower left corner and align bracket two upper holes with corresponding side panel lower dimples.

- The remaining lower bracket hole must align with a matching bottom boiler left side panel top positioning dimple.
 - Once bracket holes and side panel dimple alignment is verified, attach the bracket to top and bottom boiler left side panels with the mounting screws.
- e. Repeat above procedure to install second stacking boiler attachment bracket and secure the stacked boiler right side panels together at the front right corner.
 - f. Install the third stacking boiler attachment bracket to secure top and bottom boiler left side panels at the rear left corner. Align the bracket holes with corresponding positioning dimples in the top boiler and bottom boiler left side panels, then secure bracket with the screws.
 - g. Repeat above procedure to install the fourth stacking boiler attachment bracket to secure stacked boiler right side panels at the rear right corner.

3. When installing stackable boiler combinations observe the following guidelines:

- a. Venting - Top and bottom boilers must have their individual vent piping and vent terminals.

WARNING

Asphyxiation Hazard. No common manifold venting is permitted. Each boiler must have its own individual vent and combustion air pipes and terminals.

For sidewall venting individual model vent terminals must terminate no closer than 12 in. (300 mm) horizontally and 3 ft. (900 mm) vertically from each other in order to prevent combustion air contamination. For vertical through the roof venting, individual vertical vent terminals, if level with each other, must be spaced no closer than 12 in. (300 mm) horizontally. If vertical terminals cannot end in one plane, they must be spaced no closer than 3 ft. (900 mm) horizontally.

Follow instructions in Section IV “Venting” of the manual for specifics of individual boiler vent termination. Follow instructions in Section V “Condensate Disposal” for each individual boiler flue gas condensate line construction and condensate disposal. Terminating individual boiler condensate lines into common pipe prior to drain disposal is permissible, providing common pipe has sufficient flow capacity to handle combined condensate volume of stackable combination.

III. Pre-Installation and Boiler Mounting H. Boiler Stacking (continued)

- b. Gas Piping - Follow instructions in Section VII “Gas Piping” of the manual for sizing and installation of an individual boiler. When common gas piping is sized, insure it will have adequate capacity for combined input (CFH gas flow) of the selected stackable boiler combination.
- c. Water Piping and Trim - Follow instructions in Section VI “Water Piping and Trim” of the manual for system piping and boiler secondary

piping selection/sizing based on combined heating capacity and/or gross output of the selected stackable boiler combination. Follow instructions of Section VI “Water Piping and Trim” for each individual boiler trim installation.

- d. Electrical - Follow instructions in Section VIII “Electrical” of the manual to wire individual boilers.

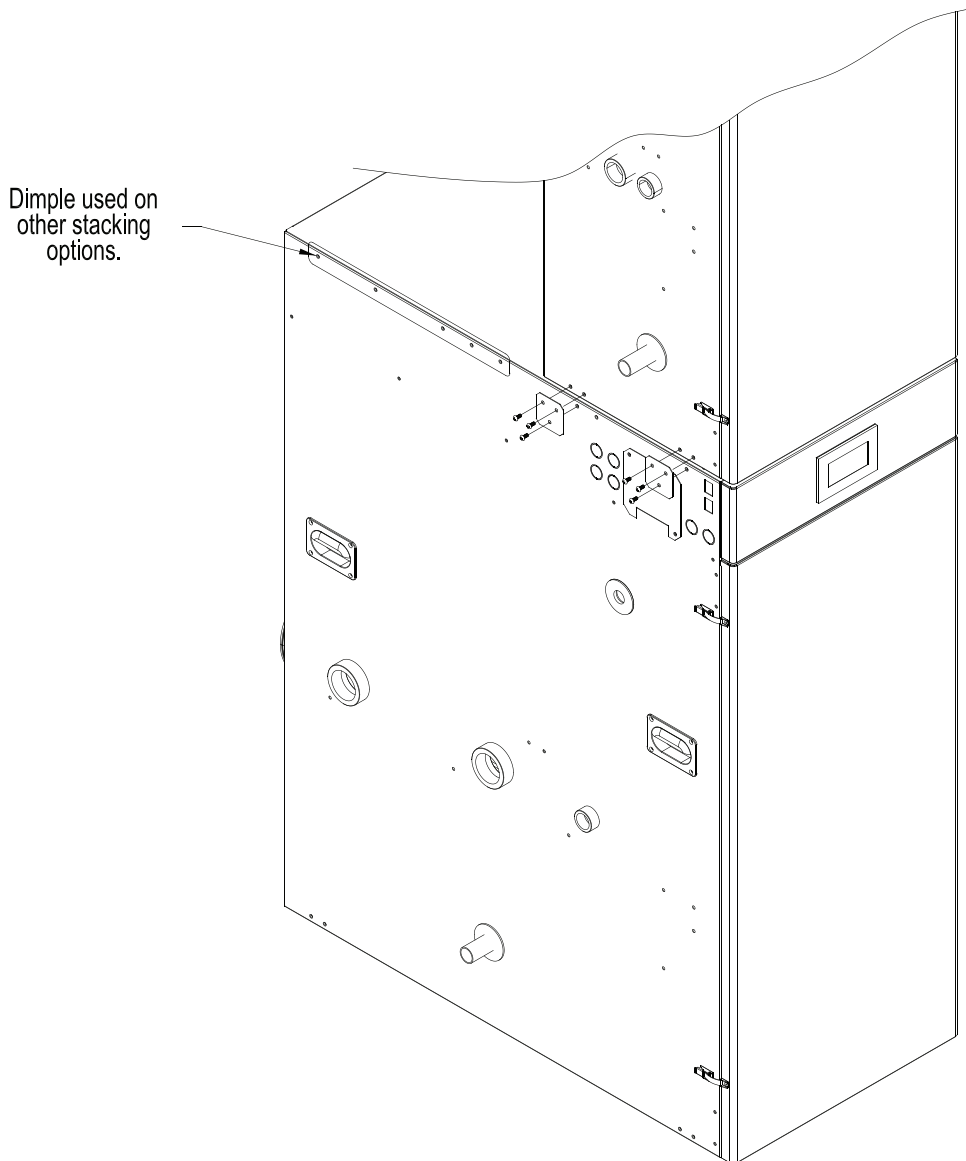

Figure 3: Stacking Boiler Attachment Bracket Placement

IV. Venting



WARNING

Asphyxiation Hazard. Failure to vent this boiler in accordance with these instructions could cause products of combustion to enter the building resulting in severe property damage, personal injury or death.

Do not use a barometric damper, draft hood or vent damper with this boiler.

Do not locate vent termination under a deck.

Do not locate vent termination where exposed to prevailing winds.

Do not locate combustion air termination where chlorines, chlorofluorocarbons (CFC's), petroleum distillates, detergents, volatile vapors or other chemicals are present. Severe boiler corrosion and failure will result.

Use outdoor air for combustion. Do not obtain combustion air from within the building.

Use specified vent and combustion air pipe diameters. Do not reduce specified diameters of vent and combustion air piping.

Do not interchange vent systems or materials unless otherwise specified.

Do not apply thermal insulation to vent pipe or fittings.

Moisture and ice may form on surface around vent termination. To prevent deterioration, surface must be in good repair (sealed, painted, etc.).

Do not allow low spots in the vent where condensate may pool.

The CPVC vent materials supplied with this boiler do not comply with *Natural Gas and Propane Installation Code*, CAN/CSA B149.1.S1-07 and are not approved for use in Canadian jurisdictions that require vent systems be listed to ULC S636-2008. In these jurisdictions, vent this boiler using either stainless steel Special Gas vent or a listed ULC S636 Class IIB venting system.

A. General Guidelines

1. Listed Vent/Combustion Air Systems

- a. Install vent system in accordance with *National Fuel Gas Code*, ANSI Z223.1/NFPA 54 or *Natural Gas and Propane Installation Code*, CAN/CSA B149.1 Installation Code for Canada, or, applicable provisions of local building codes. Contact local building or fire officials about restrictions and installation inspection in your area.
- b. The Apex is a Direct Vent (sealed combustion) boiler. Combustion air must be supplied directly to the burner enclosure from outdoors and flue gases must be vented directly outdoors.
- c. The following combustion air/vent system options are listed for use with the Apex boilers (refer to Table 4):
 - i. Two-Pipe CPVC/PVC Vent/Combustion Air System - Separate CPVC/PVC pipe serves to expel products of combustion and separate PVC pipe delivers fresh outdoor combustion air. Refer to Part B for specific details.
 - ii. Two-Pipe Polypropylene Vent/Combustion Air System - Separate rigid or flexible polypropylene pipe serves to expel products of combustion and separate rigid polypropylene or PVC pipe delivers fresh

outdoor combustion air. Refer to Part C for specific details.

- iii. Two-Pipe Stainless Steel Vent/Combustion Air System - Separate stainless steel pipe serves to expel products of combustion and separate PVC or galvanized steel pipe delivers fresh outdoor combustion air. Refer to Part D for specific details.

2. Vent/Combustion Air Piping

- a. Do not exceed maximum vent/combustion air lengths listed in Table 5. Vent/combustion air length restrictions are based on equivalent length of vent/combustion air pipe (total length of straight pipe plus equivalent length of fittings). Table 6A lists equivalent lengths for fittings. Do not include vent/combustion air terminals in equivalent feet calculations. Use vent/combustion air equivalent length worksheet provided in Table 6B.
- b. Maintain minimum clearance to combustible materials. See Figure 2 for details.
- c. Enclose vent passing through occupied or unoccupied spaces above boiler with material having a fire resistance rating at least equal to the rating of adjoining floor or ceiling.

Note: For one or two family dwellings, fire resistance rating requirement may not need to be met, but is recommended.

IV. Venting A. General Guidelines (continued)

Table 4: Vent/Combustion Air System Options

Approved Direct Vent System	Vent Material	Orientation	Termination	Description	Figures	Component Table	Part
<u>Factory Standard</u> Two-Pipe, CPVC/PVC Vent and PVC Air Intake	CPVC/PVC	Horizontal	Standard (through sidewall)	The system includes separate CPVC vent pipe and PVC air intake pipe terminating through sidewall with individual penetrations for the vent and air intake piping and separate terminals (tees).	4, 5A, 5B 9 through 13	7A	B.
			Optional Snorkel (through sidewall)	Same as above but separate snorkel type terminals.	4, 6A, 6B 9 through 13	7B	
		Optional Vertical	Vertical (through roof)	The system includes separate CPVC vent pipe and PVC air intake pipe terminating through roof with individual penetrations for the vent and air intake piping and separate vertical terminals.	7 through 11 13	7C	
<u>Available Optional</u> Two-Pipe, Rigid Polypropylene Vent (or Flexible Polypropylene Liner for Vertical venting only) and Rigid Polypropylene or PVC Pipe Air Intake	Rigid Polypropylene (or Flexible Polypropylene Liner for vertical Venting only)	Horizontal	Standard (through sidewall)	The system includes separate Rigid Polypropylene vent pipe and Rigid Polypropylene or PVC air intake pipe terminating through sidewall with individual penetrations for the vent and air intake piping and separate terminals (tees).	4, 5A, 5B 9, 12, 14	10A, 10B	C.
			Optional Snorkel (through sidewall)	Same as above but separate snorkel type terminals.	4, 6A, 6B 9, 12, 14	10A, 10B	
		Optional Vertical	Vertical (through roof or chimney/chase)	The system includes separate Flexible Polypropylene vent liner and Rigid Polypropylene vent pipe combination for venting and Rigid Polypropylene or PVC air intake pipe terminating through roof with individual penetrations for the vent and air intake and separate terminals.	7 through 9 14, 15	10A, 10B	
<u>Available Optional</u> Two-Pipe, Stainless Steel Vent and PVC/Galvanized Steel Air Intake	Stainless Steel	Horizontal	Standard (through sidewall)	The system includes separate stainless steel vent pipe and PVC/galvanized steel air intake pipe terminating through sidewall with individual penetrations for the vent and air intake piping and separate terminals.	4, 5A, 5B 9, 12, 16	11A, 11B	D.
			Optional Snorkel (through sidewall)	Same as above but separate snorkel type terminals.	4, 6A, 6B 9, 12, 16		
		Vertical	Vertical (through roof)	The system includes separate stainless steel vent pipe and PVC/galvanized steel air intake pipe terminating through roof with individual penetrations for the vent and air intake piping and separate terminals.	7 through 9 16		

**Table 5: Vent/Combustion Air Pipe Length – Two-Pipe Direct Vent System Options
CPVC/PVC; Polypropylene (PP) or Polypropylene (PP)/PVC; Stainless Steel/PVC or Galvanized Steel**

Boiler Model	Combustion Air			Vent		
	Nominal Pipe Diameter	Minimum Equivalent Length	Maximum Equivalent Length	Nominal Pipe Diameter	Minimum Equivalent Length	Maximum Equivalent Length
APX425	4 in. (100 mm or 110 mm)	2.5 ft. (760 mm)	100 ft. (30.5 m)	4 in.	2.5 ft.	100 ft.
APX525				(100 mm or 110 mm)	(760 mm)	(30.5 m)
APX625	6 in. (150 mm or 160 mm)	2.5 ft. (760 mm)	200 ft. (61.0 m)	6 in.	2.5 ft.	200 ft.
APX725				(150 mm or 160 mm)	(760 mm)	(61.0 m)
APX825				(150 mm or 160 mm)	(760 mm)	(61.0 m)

Table 6A: Vent System and Combustion Air System Components Equivalent Length vs. Component Nominal Diameter

Vent or Combustion Air System Component Description	Equivalent Length for Vent or Combustion Air System Component vs. Component Nominal Diameter	
	4 in. (100 mm or 110 mm)	6 in. (150 mm or 160 mm)
90° Elbow (Short Radius)	13 ft. (4.0 m)	22 ft. (6.7 m)
45° Elbow (Short Radius)	4.5 ft. (1.4 m)	7.5 ft. (2.3 m)

IV. Venting A. General Guidelines (continued)

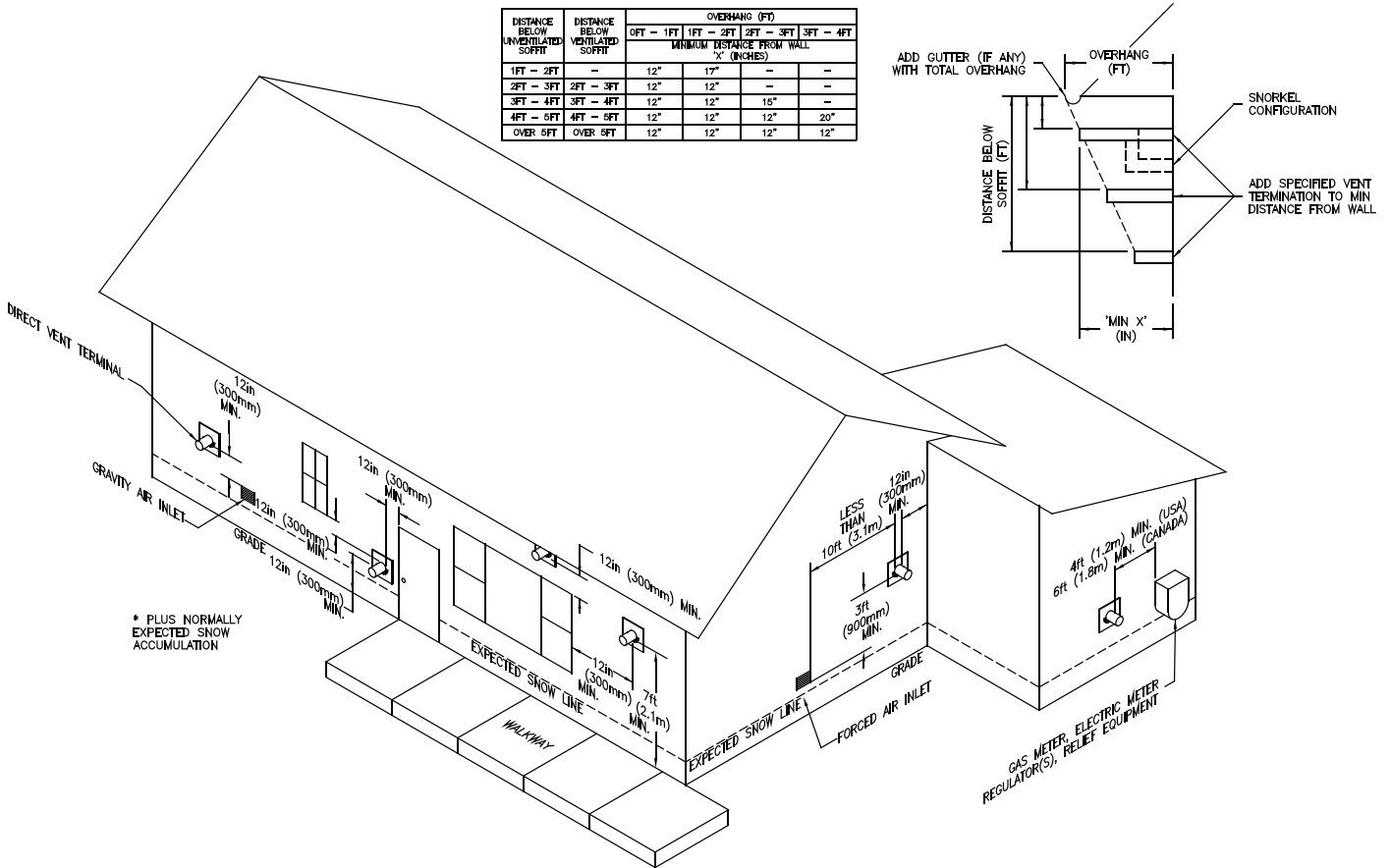

Figure 4: Location of Vent Terminal Relative to Windows, Doors, Grades, Overhangs, Meters and Forced Air Inlets - Two-Pipe System Vent Terminal (Shown), Two-Pipe System Air Intake Terminal (Not Shown)

- d. Slope horizontal vent pipe minimum 1/4 in/ft (21 mm/m) downward towards the boiler.
Les chaudières de catégories I, II et IV doivent présenter des tronçons horizontaux dont la pente montante est d'au moins 1/4 po par pied (21 mm/m) entre la chaudière et l'évent.
- e. If possible, slope horizontal combustion air pipe minimum 1/4 in/ft (21 mm/m) downward towards terminal. If not, slope towards boiler.
- f. Use noncombustible 3/4 in. pipe strap to support horizontal runs and maintain vent location and slope while preventing sags in pipe. Do not restrict thermal expansion or movement of vent system. Maximum support spacing 4 ft. (1.2 m). Avoid low spots where condensate may pool. Do not penetrate any part of the vent system with fasteners.
Les instructions d'installation du système d'évacuation doivent préciser que les sections horizontales doivent être supportées pour

- prévenir le fléchissement. Les méthodes et les intervalles de support doivent être spécifiés. Les instructions doivent aussi indiquer les renseignements suivants:
- les chaudières de catégories II et IV doivent être installées de façon à empêcher l'accumulation de condensat: et
- si nécessaire, les chaudières de catégories II et IV doivent être pourvues de dispositifs d'évacuation du condensat.
- g. For multiple boiler installations with vertical roof terminals, separate vent pipes from multiple boilers may be piped through a common conduit or chase so that one roof penetration may be made.

3. Vent/Combustion Air Terminals

Install venting system components on exterior of building only as specifically required by these instructions (refer to Figure 4).

IV. Venting A. General Guidelines (continued)

Table 6B: Vent/Combustion Air Equivalent Length Calculation Work Sheet

Combustion Air				Vent			
90° Elbow(s) (Installer Supplied)				90° Elbow(s) (CPVC Supplied with Boiler)			
Nominal Diameter	Quantity (Pc)	Equivalent Length, per Pc	Subtotal, Equivalent Length (A)	Nominal Diameter	Quantity (Pc)	Equivalent Length, per Pc	Subtotal, Equivalent Length (D)
4 in. (100 mm or 110 mm)		13 ft. (4.0 m)		4 in. (100 mm or 110 mm)	1	13 ft. (4.0 m)	13 ft. (4.0 m)
6 in. (150 mm or 160 mm)		22 ft. (6.7 m)		6 in. (150 mm or 160 mm)	1	22 ft. (6.7 m)	22 ft. (6.7 m)
45° Elbow(s) (Installer Supplied)				90° Elbow(s) (Installer Supplied)			
Nominal Diameter	Quantity (Pc)	Equivalent Length, per Pc	Subtotal, Equivalent Length (B)	Nominal Diameter	Quantity (Pc)	Equivalent Length, per Pc	Subtotal, Equivalent Length (A)
4 in. (100 mm or 110 mm)		4.5 ft. (1.4 m)		4 in. (100 mm or 110 mm)		13 ft. (4.0 m)	
6 in. (150 mm or 160 mm)		7.5 ft. (2.3 m)		6 in. (150 mm or 160 mm)		22 ft. (6.7 m)	
Straight Pipe, (Installer Supplied)				45° Elbow(s) (Installer Supplied)			
Nominal Diameter	Quantity Length, ft or m	Equivalent Length, ft/ft or m/m	Subtotal, Equivalent Length (C)	Nominal Diameter	Quantity Length, ft or m	Equivalent Length, ft/ft or m/m	Subtotal, Equivalent Length (B)
4 in. (100 mm or 110 mm)		1		4 in. (100 mm or 110 mm)		4.5 ft. (1.4 m)	
6 in. (150 mm or 160 mm)		1		6 in. (150 mm or 160 mm)		7.5 ft. (2.3 m)	
* Total Equivalent Length (A+B+C) =				2.5 Ft. (760 mm) Straight Pipe, (CPVC Supplied with Boiler)			
* Notes: 1. Calculated total equivalent length cannot exceed maximum equivalent length shown in Table 5. 2. Vent and combustion air terminals do not count towards total equivalent length. 3. Pressure drop for flexible polypropylene liner is 20% greater than for rigid pipe. Multiply measured flexible polypropylene liner length by 1.2 to obtain equivalent length. <u>Example</u> Measure length of flexible polypropylene liner = 35 ft. Equivalent length of flexible polypropylene liner = 35 ft. x 1.2 = 42 ft. 4. Maximum equivalent length of flexible polypropylene liner is 48 ft. (14.6 m). 5. All elbows referenced are short radius.				Nominal Diameter	Quantity Length, ft or m	Equivalent Length, ft/ft or m/m	Subtotal, Equivalent Length (E)
				4 in. (100 mm or 110 mm)	2.5 ft. (0.76 m)	1	2.5 ft. (0.76 m)
				6 in. (150 mm or 160 mm)	2.5 ft. (0.76 m)	1	2.5 ft. (0.76 m)
				Straight Pipe, (Installer Supplied)			
				Nominal Diameter	Quantity Length, ft	Equivalent Length, ft/ft	Subtotal, Equivalent Length (C)
4 in. (100 mm or 110 mm)		1					
6 in. (150 mm or 160 mm)		1					
* Total Equivalent Length (A+B+C+D+E) =							

- a. Use only listed vent/combustion air terminals.
 - i. Horizontal Sidewall Venting: For models APX425 and APX 525, use tee terminals for both vent and combustion air as shown in Figure 5A. For models APX625, APX725, and APX825, use tee terminals or 90° elbows for both vent and combustion air as shown in Figure 5A or Figure 5B. Alternate snorkel terminations are shown in Figure 6A and Figure 6B.
 - ii. Vertical Roof Venting: Use straight coupling on vent and two 90° elbows turned downwards for combustion air as shown in Figure 7 and Figure 8.
- b. Maintain correct clearance and orientation between vent and combustion air terminals.

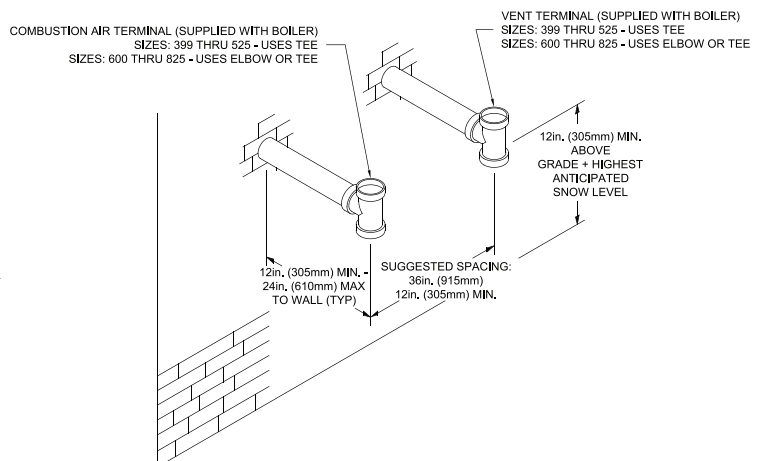

Figure 5A: Direct Vent - Sidewall Tee Terminations

IV. Venting A. General Guidelines (continued)

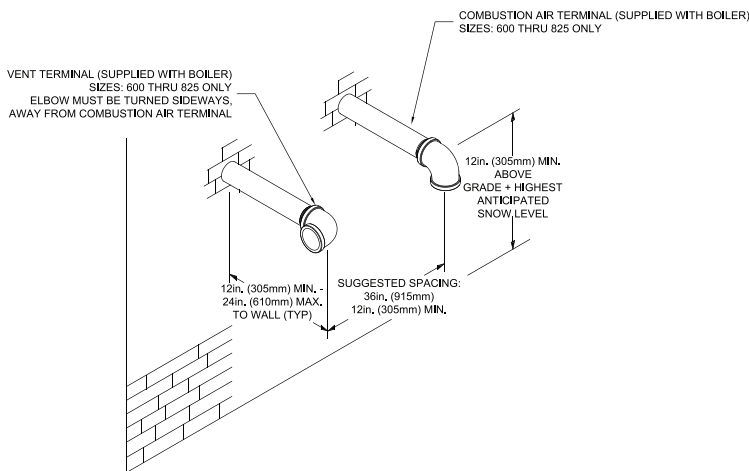

Figure 5B: Direct Vent - Sidewall Elbow Terminations, Size 625 through 825 Only

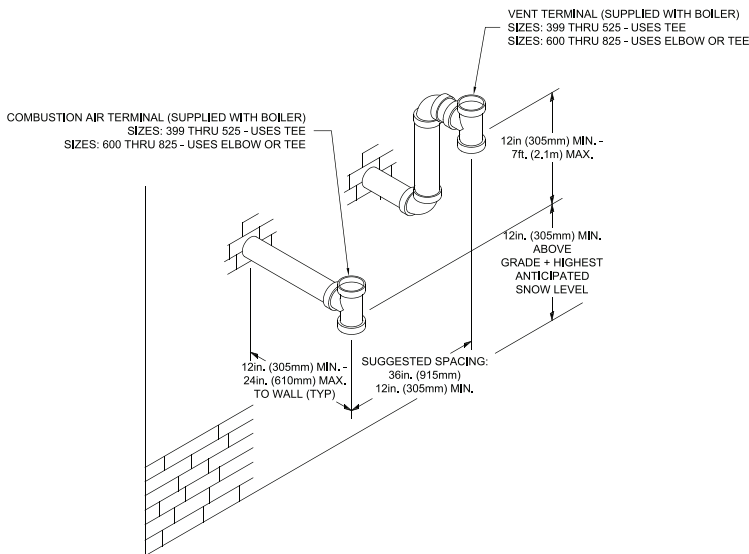

Figure 6A: Direct Vent - Optional Vent Sidewall Snorkel Termination

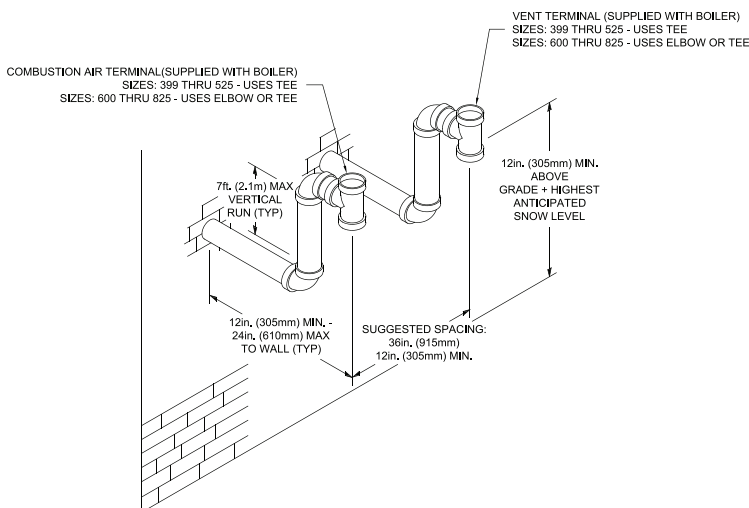

Figure 6B: Direct Vent - Optional Vent and Combustion Air Sidewall Snorkel Terminations

- i. Space centerlines of vent and combustion air terminals minimum 12 in. (300 mm) apart. More than 12 in. (300 mm) spacing is recommended.
 - ii. If possible, locate vent and combustion air terminals on the same wall to prevent nuisance shutdowns. If not, boiler may be installed with roof vent terminal and sidewall combustion air terminal.
 - iii. When installed on the same wall, locate vent terminal at same height or higher than combustion air terminal.
 - iv. When using tee terminals, do not locate vent terminal directly above air intake as dripping condensate may freeze on and block intake.
- c. Locate bottom of vent and combustion air terminals at least 12 in. (300 mm) [18 in. (460 mm) in Canada] above the normal snow line and at least 12 in. (300 mm) above grade level.
 - d. Locate vent and combustion air terminals at least 12 in. (300 mm) from any door, window, or gravity inlet into the building.
 - e. Do not install vent terminal directly above windows or doors.
 - f. Locate bottom of vent terminal at least 3 ft. (900 mm) above any forced air inlet located within 10 ft. (3.0 m).
 - g. If window and/or air inlet is within 4 ft. (1.2 m) of an inside corner, maintain at least 6 ft. (1.8 m) spacing between terminal and adjoining wall of inside corner.
 - h. Locate bottom of vent terminal at least 7 ft. (2.1 m) above a public walkway.
 - i. Maintain minimum clearance of at least 4 ft. (1.2 m) [3 ft. (900 mm) in Canada] horizontally between vent terminal and gas meters, electric meters, regulators, and relief equipment. Do not install vent terminal above or below this equipment.
 - j. Do not locate the vent terminal under decks or similar structures.
 - k. Top of terminal must be at least 24" below ventilated eaves, soffits, and other overhangs. In no case may the overhang exceed 48". Where permitted by the authority having jurisdiction and local experience, the terminal may be located closer to unventilated soffits. The minimum vertical separation depends upon the depth of the soffit. See Figure 4 for details.
 - l. Maintain minimum 12 in. (300 mm) horizontal spacing between vent terminal and a building corner.
 - m. Under certain conditions, water in the flue gas may condense, and possibly freeze, on objects around the terminal including on the structure

IV. Venting A. General Guidelines - B. CPVC/PVC Venting (continued)

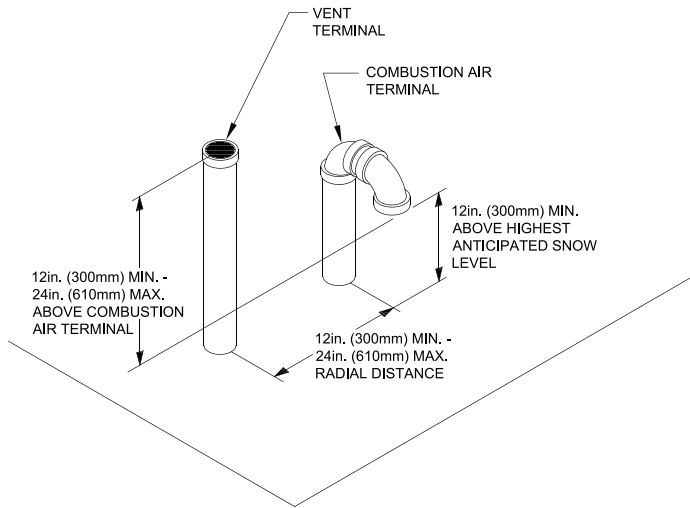

Figure 7: Direct Vent - Vertical Terminations

itself. If these objects are subject to damage by flue gas condensate, they should be moved or protected.

- n. If possible, install the vent and combustion air terminals on a wall away from the prevailing wind. Reliable operation of this boiler cannot be guaranteed if terminals are subjected to winds in excess of 40 mph (64 km/hr).
- o. Do not locate combustion air terminal in areas that might contain combustion air contaminants, such as near swimming pools.
- p. For multiple boiler installations with horizontal wall terminals, maintain minimum 12 in. (300 mm) horizontal distance between adjacent boiler vent terminals. Maintaining greater spacing is recommended to avoid frost damage to building surfaces where vent terminations are placed.

- q. For multiple boiler installations with vertical roof terminals, maintain minimum 12 in. (300 mm) horizontal distance between adjacent boiler vent terminals.

B. CPVC/PVC Venting

WARNING

Asphyxiation Hazard. Failure to follow these instructions could cause products of combustion to enter the building, resulting in severe property damage, personal injury, or death.

Use all CPVC vent components (supplied with boiler) for near-boiler vent piping before transitioning to Schedule 40 PVC pipe (ASTM 2665) components for remainder of vent system.

Use CPVC vent components within any interior space where air cannot circulate freely, including through vertical or horizontal chase ways, inside a stud wall, in closets, and through wall penetrations.

The use of cellular core PVC (ASTM F891), cellular core CPVC or Radel (polyphenolsulfone) is prohibited.

All condensate that forms in the vent must be able to drain back to the boiler.

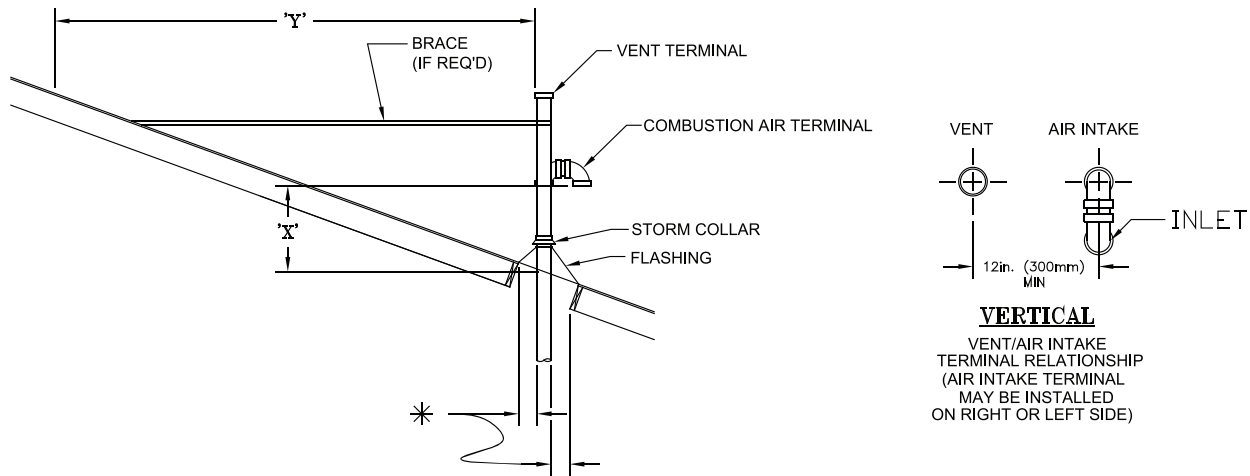

* VENT PIPE MINIMUM CLEARANCE TO COMBUSTIBLE MATERIAL IS 1in. (25mm). COMBUSTION AIR PIPE MINIMUM CLEARANCE TO COMBUSTIBLE MATERIAL IS ZERO.

Figure 8: Direct Vent - Vertical Terminations with Sloped Roof

Extend vent/combustion air piping to maintain minimum vertical ('X') and minimum horizontal ('Y') distance of 12 in. (300 mm) [18 in. (460 mm) Canada] from roof surface. Allow additional vertical ('X') distance for expected snow accumulation.

IV. Venting B. CPVC/PVC Venting (continued)

NOTICE

Do not exceed maximum vent/combustion air system length. Refer to “2. Vent/Combustion Air Piping” under “A. General Guidelines” of this section for maximum vent/combustion air system length.

Use only vent and combustion air terminals and terminal locations shown in “3. Vent/Combustion Air Terminals” under “A. General Guidelines” of this section.

1. Components

- See Table 7A for CPVC/PVC vent and combustion air components included with boiler.
- See Table 7B for CPVC/PVC installer provided vent and combustion air components required for optional horizontal snorkel terminals shown in Figure 6B.
- See Table 7C for CPVC/PVC installer provided vent and combustion air components required for optional vertical roof terminals shown in Figure 7.

2. Field Installation of CPVC/PVC Two-Pipe Vent System Connector

Refer to Figure 9 and following steps:

- Position the CPVC/PVC vent connector and gasket onto boiler rear panel and insert vent connector inner stainless steel vent pipe into heat exchanger vent outlet.
- Align vent connector plate and gasket clearance holes with rear panel engagement holes. Then, secure the connector and gasket to the panel with six mounting screws.
- Attach flue temperature sensor wiring harness (taped to boiler rear panel) female connectors to the sensor male spade terminals. Failure to do so will prevent boiler from starting and boiler display will flash Red and display Limit String Fault (see Section XII “Troubleshooting” for details).

NOTICE

Flue temperature sensor harness must be connected to flue temperature sensor for the boiler to start-up and operate properly. The installation is not complete unless the harness and the sensor are interconnected.

Table 7A: CPVC/PVC Vent & Air Intake Components Included With Boiler

Vent & Air Intake Components	Quantity	
	Models APX425 & APX525 Standard 4 In. Termination Vent Kit (P/N 102189-03) includes	Models APX625, APX725 & APX825 Standard 6 In. Termination Vent Kit (P/N 103253-01) includes
Schedule 40 PVC Tee	102190-02 (Qty. 2)	N/A
Schedule 40 PVC 90° Elbow	N/A	103313-01 (Qty. 2)
Stainless Steel Rodent Screen	102191-02 (Qty. 2)	102191-03 (Qty. 2)
30 in. Schedule 40 CPVC Pipe	102193-02	103267-01
Schedule 80 CPVC 90° Elbow	102192-02	103268-01
4 oz. Bottle of Transition Cement	102195-01	
4 oz. Bottle of Primer	102194-01	
CPVC/PVC Connector	4 in. x 4 in. 102183-03	6 in. x 6 in. 103270-01
CPVC/PVC Connector Gasket	4 in. x 4 in. 102185-02	6 in. x 6 in. 103248-01

Table 7B: CPVC/PVC Vent & Air Intake Components (Installer Provided) required for Optional Horizontal (Snorkel) Termination

Vent Components	Quantity	
	APX425 & APX525 Horizontal (Snorkel) Termination, 4 in.	APX625, APX725 & APX825 Horizontal (Snorkel) Termination, 6 in.
Schedule 40 PVC Pipe x up to 7 ft. (2.1 m) max. vertical run	2	2
Schedule 40 PVC 90° Elbow	4	4
Schedule 40 PVC Pipe x 6 in. (150 mm) min. horizontal run	2	N/A
Schedule 40 PVC Pipe x 9 in. (230 mm) min. horizontal run	N/A	2

IV. Venting B. CPVC/PVC Venting (continued)

Table 7C: CPVC/PVC Vent & Air Intake Components (Installer Provided) required for Optional Vertical (Roof) Termination

Vent Components	Quantity	
	APX425 & APX525 Vertical (Roof) Termination, 4 in.	APX625, APX725 & APX825 Vertical (Roof) Termination, 6 in.
Schedule 40 PVC Coupler	1	1
Schedule 40 PVC 90° Elbow	2	2
Schedule 40 CPVC Pipe x 6 in. (150 mm) min. horizontal run	1	N/A
Schedule 40 CPVC Pipe x 9 in. (230 mm) min. horizontal run	N/A	1

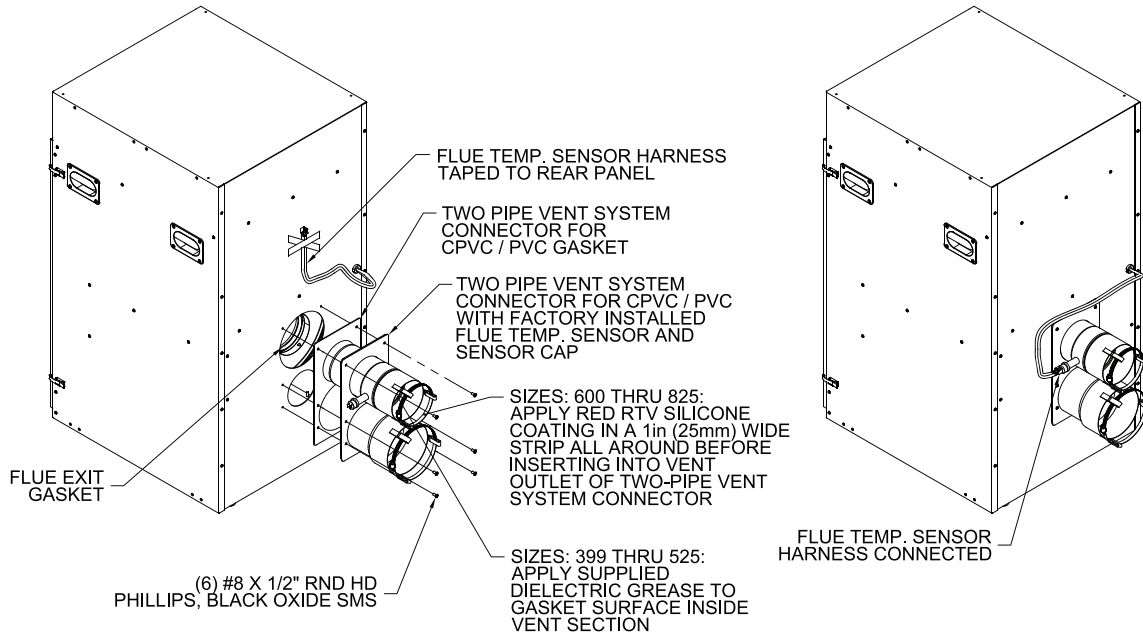

Figure 9: Field Installation of CPVC/PVC Two-Pipe Vent Connector with Factory Installed Flue Temperature Sensor and Sensor Cap

3. Near-Boiler Vent/Combustion Air Piping

Refer to Figure 10 and the following Steps:

a. Models APX425 and APX525 only:

Apply supplied dielectric grease (grease pouch attached to two-pipe vent connector) to gasket

inside vent section of 4 in. x 4 in. two-pipe vent connector. The grease will prevent vent gasket rupture when inserting vent pipe and gasket deterioration due to condensate exposure.

! WARNING

Asphyxiation Hazard. Models APX425 and APX525 only: Apply supplied dielectric grease to gasket inside vent section of two-pipe vent connector. Failure to apply the grease could result in flue gas leaks from gasket rupture during vent pipe installation or gasket deterioration due to condensate exposure.

Models APX625, APX725, and APX825 only: Two-pipe vent connector does not have gasketed seal. Apply supplied red RTV silicon sealant to circumference of vent pipe before inserting pipe into vent connector. Failure to apply the silicon could result in flue gas leaks.

IV. Venting B. CPVC/PVC Venting (continued)

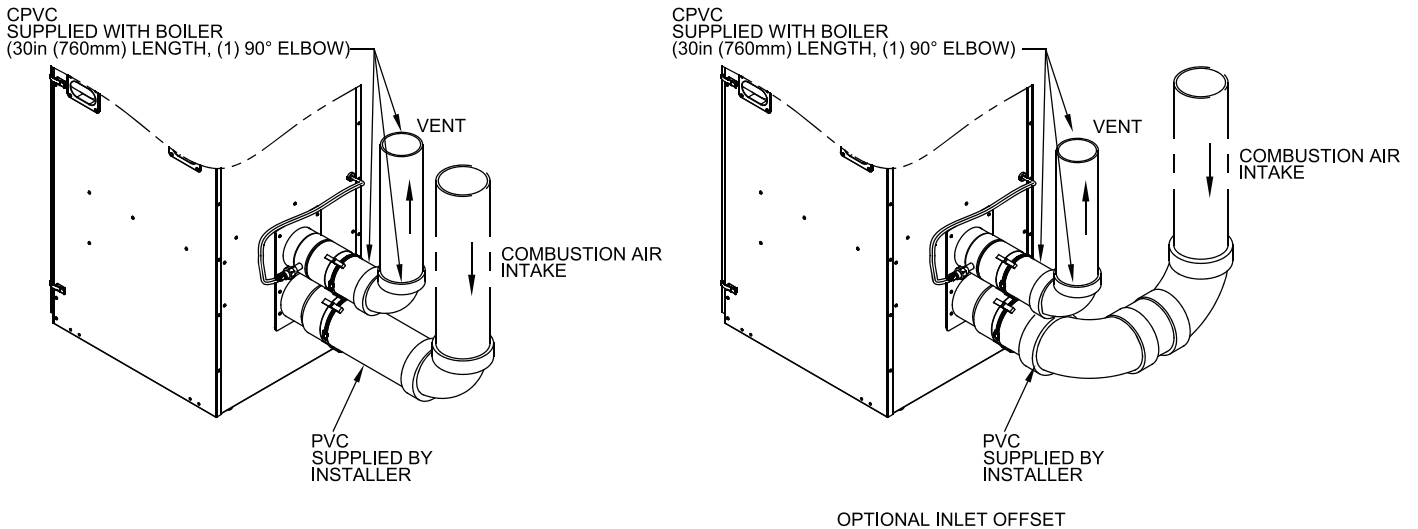

Figure 10: Near-Boiler Vent/Combustion Air Piping

- b. Models APX625, APX725, and APX825 only: 6 in. x 6 in. two-pipe connector does not have factory installed internal sealing gaskets at both vent and combustion air sections. Apply a coating of supplied red RTV silicon sealant, at least 1 in. (25 mm) wide, around circumference of provided 6 in. Schedule 40 x 30 in. (760 mm) long CPVC pipe.
- c. Install provided Schedule 40 x 30 in. (760 mm) long CPVC pipe into the vent section of the connector with a slight twisting motion and secure by tightening the worm band clamp screw.
- d. All CPVC vent components supplied with boiler inside vent carton [Schedule 40 x 30 in. (760 mm) long CPVC pipe and Schedule 80 CPVC 90° Elbow] must be used for near-boiler piping before transitioning to Schedule 40 PVC (ASTM 2665) pipe components for remainder of vent system. The 30 in. (760 mm) long CPVC straight pipe may be cut to accommodate desired vent configuration provided both pieces are used in conjunction with CPVC 90° Elbow before any PVC components are used. Ensure that the CPVC 90° Elbow is the first elbow used in the vent system as it exits the boiler.
- e. Insert Schedule 40 PVC combustion air pipe (installer provided) into the combustion air section of the connector with a slight twisting motion and secure by tightening the worm band clamp screw. For models APX625, APX725 and APX825: Apply supplied red RTV silicon sealant, at least 1 in. (25 mm) wide, around circumference of installer provided 6 in. Schedule 40 PVC combustion air pipe at end to be inserted into vent connector.

- f. Clean all vent and combustion air pipe joints with primer and secure with transition cement (4-oz. bottles of primer and cement are supplied with boiler inside vent carton). Follow application instructions provided on primer and cement bottles.

4. System Assembly



WARNING

Asphyxiation Hazard. CPVC/PVC vent piping and fittings rely on glued joints for proper sealing. Follow all manufacturer instructions and warnings when preparing pipe ends for joining and using the primer and the cement.

- a. Plan venting system to avoid possible contact with plumbing or electrical wires. Start at vent connector at boiler and work towards vent termination.
- b. Design the vent system to allow 3/8 in. (9.5 mm) of thermal expansion per 10 ft. (3.0 m) of CPVC/PVC pipe. Runs of 20 ft. (6.1 m) or longer that are restrained at both ends must use an offset or expansion loop. Refer to Figure 11 and Table 8.
- c. All CPVC/PVC vent and combustion air pipe joints must be cleaned with primer and glued with cement. Follow all manufacturer instructions and warnings when preparing pipe ends for joining and using the primer and the cement.

5. Horizontal Sidewall Termination

- a. Standard Two-Pipe Termination
See Figures 5A and 5B.

IV. Venting B. CPVC/PVC Venting (continued)

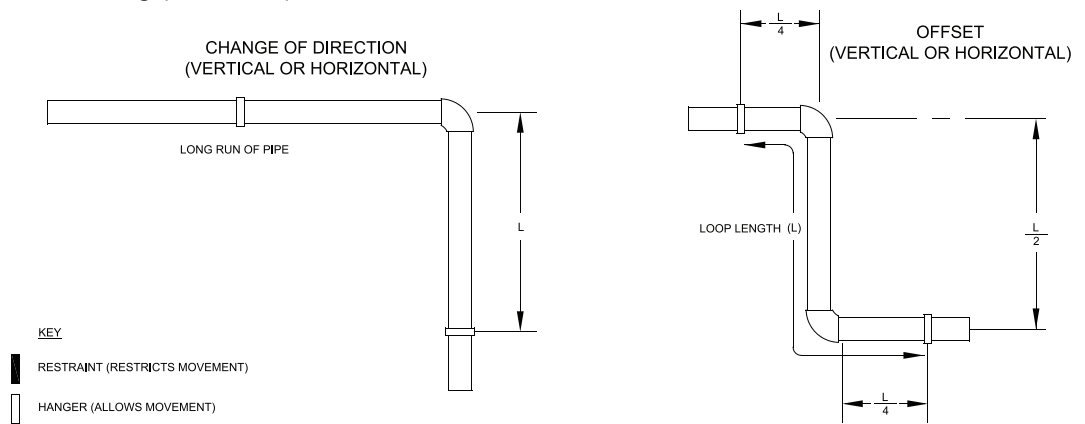

Table 8: Expansion Loop Lengths

Nominal Pipe Dia. (In.)	Length of Straight Run		Loop Length "L"	
	ft.	m	in.	mm
4	20	6.1	60	1520
	30	9.1	74	1880
	40	12	85	2159
	50	15	95	2413
	60	18	104	2642
6	20	6.1	73	1850
	30	9.1	90	2290
	40	12	103	2620
	50	15	116	2950
	60	18	127	3230

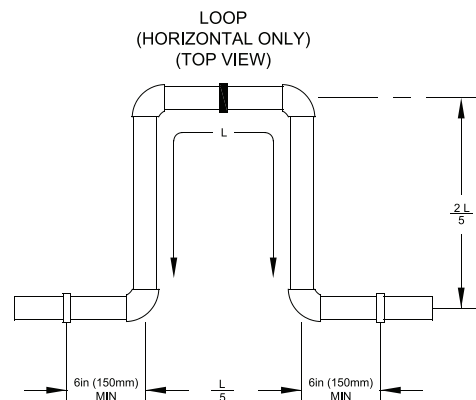

Figure 11: CPVC/PVC Expansion Loop and Offset

i. Vent Piping

Running PVC vent pipe inside Enclosures and through Walls:

- PVC vent pipe must be installed in such way as to permit adequate air circulation around the outside of the pipe to prevent internal wall temperature rising above ANSI Z21.13 standard specified limit.
- Do not enclose PVC venting. Use higher temperature rated CPVC pipe in enclosed spaces or to penetrate combustible or non-combustible walls.
- PVC vent pipe may not be used to penetrate combustible or non-combustible walls unless all following three conditions are met simultaneously (see Figure 12):
 - The wall penetration is at least 66 in. (1680 mm) from the boiler as measured along the vent
 - The wall is 12 in. (300 mm) thick or less
 - An air space of at least of that shown in Figure 12 is maintained around outside of the vent pipe to provide air circulation

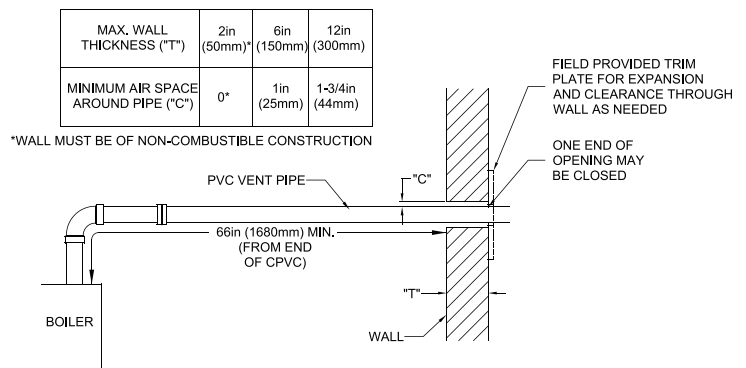

Figure 12: Wall Penetration Clearances for PVC Vent Pipe

- If above three conditions cannot be met simultaneously when penetrating a combustible wall, use CPVC pipe for wall penetration.
- Size and cut wall opening such that a minimal clearance is obtained and to allow easy insertion of vent pipe.
- Apply sealant between vent pipe and wall opening to provide weather-tight seal. Sealant should not restrain the expansion of the vent pipe.

IV. Venting B. CPVC/PVC Venting (continued)

- Install contractor provided optional trim plate on wall outside surface to cover wall opening (see Figure 12).
- Secure trim plate to wall with nails or screws and seal ID and plate OD or perimeter with sealant material.
- Install rodent screen and vent terminal (supplied with boiler). See Figure 13 for appropriate configuration details.

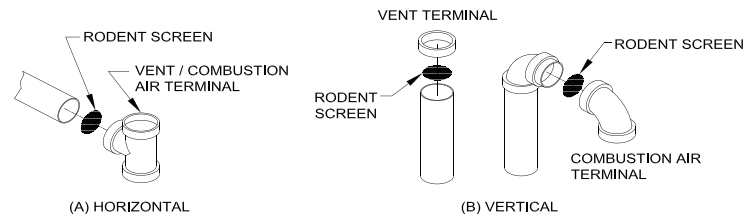

Figure 13: Rodent Screen Installation

NOTICE

Methods of securing and sealing terminals to the outside wall must not restrain the thermal expansion of the vent pipe.

- ii.* Combustion Air Piping
 - Size combustion air pipe wall penetration opening to allow easy insertion of the pipe.
 - Install rodent screen and combustion air terminal (supplied with boiler). See Figure 13 for appropriate configuration details.
 - Apply sealant between combustion air pipe and wall opening to provide weather-tight seal.

- b.* Optional Two-Pipe Snorkel Termination
See Figures 6A and 6B.

This installation will allow a maximum of 7 ft. (2.1 m) vertical exterior run of the vent/combustion air piping to be installed on the CPVC/PVC horizontal venting application.

NOTICE

Exterior run to be included in equivalent vent/combustion air lengths.

- i.* Vent Piping
 - After penetrating wall, install a Schedule 40 PVC 90° elbow so that the elbow leg is in the up direction.
 - Install maximum vertical run of 7 ft. (2.1 m) of Schedule 40 PVC vent pipe. See Figure 6A.
 - At top of vent pipe length install another PVC 90° elbow so that elbow leg is opposite the building's exterior surface.
 - Install rodent screen and vent terminal (supplied with boiler), see Figure 13 for appropriate configuration.
 - Brace exterior piping if required.

- ii.* Combustion Air Piping

- After penetrating wall, install a Schedule 40 PVC 90° elbow so that elbow leg is in the up direction.
- Install maximum vertical run of 7 ft. (2.1 m) of Schedule 40 PVC vent pipe. See Figure 6B.
- At top of air pipe length install another PVC 90° elbow so that elbow leg is opposite the building's exterior surface.
- Install rodent screen and combustion air terminal (supplied with boiler). See Figure 13 for appropriate configuration.
- Brace exterior piping if required.

6. Vertical Roof Termination

- a.* Standard Two-Pipe Termination

See Figures 7 and 8.

- i.* Vent Piping

- Install fire stops where vent passes through floors, ceilings or framed walls. The fire stop must close the opening between the vent pipe and the structure.
- Whenever possible, install vent straight through the roof. Refer to Figures 7 and 8.
 - Size roof opening to maintain minimum clearance of 1 in. (25 mm) from combustible materials.
 - Extend vent pipe to maintain minimum vertical and horizontal distance of 12 in. (300 mm) from roof surface. Allow additional vertical distance for expected snow accumulation. Provide brace as required.

NOTICE

Vertical venting and combustion air roof penetrations (where applicable) require the use of roof flashing and storm collar, which are not supplied with boiler, to prevent moisture from entering the structure.

IV. Venting B. CPVC/PVC Venting - C. Polypropylene Venting (continued)

- Install storm collar on vent pipe immediately above flashing. Apply Dow Corning Silastic 732 RTV Sealant or equivalent between vent pipe and storm collar to provide weather-tight seal.
- Install rodent screen and vent terminal (supplied with boiler). See Figure 13 for appropriate configuration.
- Brace exterior piping if required.
- ii. Combustion Air Piping
 - If possible, locate combustion air termination on the same roof location as the vent termination to prevent nuisance boiler shutdowns. Combustion air terminal may be installed closer to roof than vent. Alternatively, boiler may be installed with vertical roof vent terminal and sidewall combustion air terminal.
 - Size roof opening to allow easy insertion of combustion air piping and allow proper installation of flashing and storm collar to prevent moisture from entering the structure.
 - Use appropriately designed vent flashing when passing through roofs. Follow flashing manufacturers' instructions for installation procedures.
 - Extend combustion air pipe to maintain minimum vertical and horizontal distance of 12 in. (300 mm) from roof surface. Allow additional vertical distance for expected snow accumulation. Provide brace as required.
 - Install storm collar on combustion air pipe immediately above flashing. Apply Dow Corning Silastic 732 RTV Sealant or equivalent between combustion air pipe and storm collar to provide weather-tight seal.
 - Install rodent screen and combustion air terminal (supplied with boiler). See Figure 13 for appropriate configuration.
 - Brace exterior piping if required.

C. Polypropylene Venting



WARNING

Asphyxiation Hazard. Follow these instructions and the installation instructions included by the original polypropylene venting component manufacturers, M&G/ DuraVent or Centrotherm, whichever applicable. Failure to do so could cause products of combustion to enter the building, resulting in severe property damage, personal injury or death. Where a conflict arises between M&G/ DuraVent or Centrotherm instructions and these instructions, the more restrictive instructions shall govern.

Do not mix vent components or joining methods for listed manufacturers.

Examine all components for possible shipping damage prior to installation.

All condensate that forms in the vent must be able to drain back to the boiler.

NOTICE

Do not exceed maximum vent/combustion air system length. Refer to "2. Vent/Combustion Air Piping" under "A. General Guidelines" of this section for maximum vent/combustion air system length.

Use only vent and combustion air terminals and terminal locations shown in "3. Vent/Combustion Air Terminals" under "A. General Guidelines" of this section.

1. Components

- a. Listed polypropylene vent system manufacturers are shown in Table 9. It is the responsibility of the installing contractor to procure polypropylene vent system pipe and related components.
- i. M&G/DuraVent PolyPro Single Wall Rigid Vent and PolyPro Flex Flexible Vent comply with the requirements of ULC-S636-08 'Standard for Type BH Gas Venting Systems'.

Table 9: Listed Polypropylene Vent System Manufacturers

Make	Model
M&G/DuraVent	PolyPro Single Wall Rigid Vent PolyPro Flex Flexible Vent (APX425 and APX525)
Centrotherm Eco Systems	InnoFlue SW Rigid Vent Flex Flexible Vent (APX425 and APX525)

IV. Venting C. Polypropylene Venting

- ii. Centrotherm Eco Systems InnoFlue SW Rigid Vent and Flex Flexible Vent comply with the requirements of UL 1738 ‘Standard for Safety for Venting Systems’ and ULC-S636-08 ‘Standard for Type BH Gas Venting Systems’.

- b. See Table 10A for specific M&G DuraVent components.
 c. See Table 10B for specific Centrotherm Eco Systems components.

2. Field Installation of CPVC/PVC Two-Pipe Vent System Connector and PVC to Polypropylene Adapter

- a. Install CPVC/PVC two-pipe vent system connector. Follow instructions in “2. Field Installation of CPVC/PVC Two-Pipe Vent System Connector” under “B. CPVC/PVC Venting.” See Figures 9 and 14.
 b. Models APX425 and APX525 only: Apply provided dielectric grease (grease pouch taped to the vent system connector) all around to the vent or air connection inner red silicon gasket.
 c. Models APX625, APX725 and APX825 only: Apply a coating of supplied red RTV silicone sealant, at least 1 in. (25 mm) wide, around circumference of PVC to PP adapter male end.
 d. Push and twist PVC to PP adapter into two-pipe vent system connector vent or combustion air supply port until bottomed out.
 e. Tighten the worm band clamp screw to secure PVC to PP adapter.

- f. Do not install PVC to PP adapter at the lower combustion air supply port of the two-pipe vent system connector when using PVC pipe for combustion air supply to boiler.

3. System Assembly

WARNING

Asphyxiation Hazard. Vent systems made by M&G/DuraVent and Centrotherm Eco Systems rely on gaskets for proper sealing. When these vent systems are used, take the following precautions:

- **Make sure that gasket is in position and undamaged in the female end of the pipe.**
- **Make sure that both the male and female pipes are free of damage prior to assembly.**
- **Only cut vent pipe as permitted by the vent manufacturer in accordance with their instructions. When pipe is cut, cut end must be square and carefully de-burred prior to assembly.**
- **Use locking band clamps at all vent pipe joints.**

- a. Plan venting system to avoid possible contact with plumbing or electrical wires. Start at vent connector at boiler and work towards vent termination.

Table 10A: Listed Polypropylene Pipe, Fittings and Terminations - M&G/DuraVent

Boiler Model	M&G / DuraVent Part Numbers/Sizes					
	Male Boiler Adapter, PVC to PP	Rigid Pipe Nominal Dia.	Flex Pipe Nominal Dia.	Pipe Joint Locking Band	Side Wall Termination Tee	Chimney Kit for Venting Only
APX425	4PPS-04PVCM-4PPF	4 in. (100 mm)	4 in. (100 mm)	43PPS-LB	43PPS-TB	4PPS-FK
APX525		6 in. (150 mm)	N/A	6PPS-LBC	6PPS-E90B	N/A
APX625	6PPS-06PVCM-6PPF					
APX725						
APX825						

Table 10B: Listed Polypropylene Pipe, Fittings and Terminations - Centrotherm Eco

Boiler Model	Centrotherm Eco Part Numbers/Sizes					
	Male Boiler Adapter, PVC to PP	Rigid Pipe Nominal Dia.	Flex Pipe Nominal Dia.	Pipe Joint Locking Band	Side Wall Termination Tee	Chimney Kit for Venting Only
APX425	ISAA0404	4 in. (110 mm)	4 in. (110 mm)	IANS04	ISTT0420	IFCK0425 and IFCK0435
APX525	ISSAL0404					
APX625	ISAA0606 ISSAL0606	6 in. (160 mm)	N/A	IANS06	ISTT0620	N/A
APX725						
APX825						

IV. Venting C. Polypropylene Venting (continued)

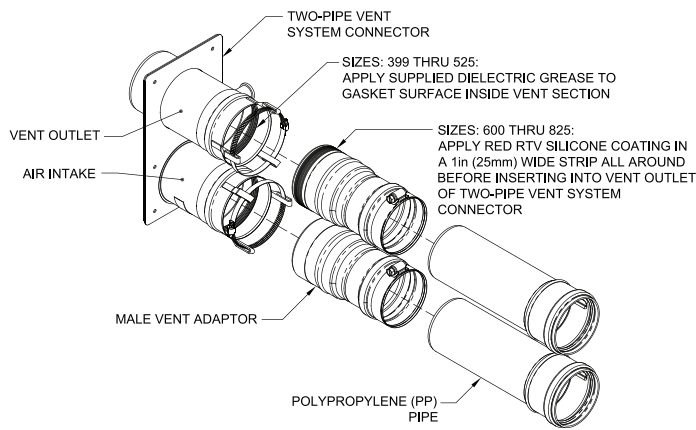

Figure 14: Vent System Field Modification to Install PVC to PP Adapter (M&G/DuraVent Shown)

- b. Follow all manufacturer instructions and warnings when preparing pipe ends for joining and when assembling the vent/combustion air system.
- c. Use locking band clamps at all vent pipe joints.

NOTICE

The venting system must be free to expand and contract and supported in accordance with installation instructions included by the original polypropylene venting component manufacturers, M&G/DuraVent or Centrotherm, whichever applicable. Polypropylene pipe sections must be disengaged 1/4 to 5/8 in. (6 mm to 16 mm) per joint to allow for thermal expansion.

4. Running Flexible Polypropylene Vent (Liner) Through Unused Chimney Chase



WARNING

Asphyxiation Hazard. Flexible polypropylene vent must be installed only in an UNUSED chimney. A chimney, either single or multiple flue type, is considered UNUSED when none of the flues is being used for any appliance venting. Where one of the multiple flues is being used for an appliance venting, the flexible vent installation is not permitted through any of adjacent flues.

NOTICE

Pressure drop for flexible polypropylene liner is 20% greater than from rigid pipe. Multiply measured flexible polypropylene liner length by 1.2 to obtain equivalent length. Maximum equivalent length of flexible polypropylene liner is 48 ft. (14.6 m).

- a. Models APX425 and APX525 are listed for vertical venting by installing flexible vent in an UNUSED masonry chimney/chase and supplying combustion air through a separate wall or roof combustion air terminal.
- b. Refer to Figure 15 for details of chimney chase installation.
- c. Flexible polypropylene pipe must be treated carefully and stored at temperatures higher than 41°F (5°C).
- d. Do not bend or attempt to install flexible pipe if it has been stored at lower ambient temperature without allowing the pipe to warm up to a higher temperature first.



WARNING

Asphyxiation Hazard. Bending or attempting to install flexible pipe if it has been stored at ambient temperature below 41°F (5°C) will cause material to become brittle and lead to cracks, resulting in flue gas leaks.

Do not install flexible polypropylene pipe at an angle greater than 45 degrees from vertical plane when used for combustion product venting. Failure to do so will result in improper condensate drainage towards the boiler and possible subsequent vent pipe blockage.

- e. When flexible polypropylene pipe (liner) is used for combustion product venting, it must not be installed at an angle greater than 45 degrees from vertical plane. This will insure proper condensate flow back towards the boiler.
- f. When flexible polypropylene pipe (liner) is used for combustion air supply to a boiler, the pipe (liner) can be installed in vertical or horizontal position.
- g. Follow flexible polypropylene pipe (liner) manufacturer specific installation instructions regarding application/listing, permits, minimum clearances to combustibles, installation details (proper joint assembly, pipe support and routing, gasket and fitting installation, optional tooling availability/usage, routing through masonry chimney for combustion product venting or, combination of combustion product venting and combustion air supply).
- h. When there is a conflict between flexible polypropylene pipe (liner) manufacturer installation instructions and Apex boiler Installation, Operating and Service Instructions, the more restrictive instructions shall govern.

IV. Venting C. Polypropylene Venting - D. Stainless Steel Venting (continued)

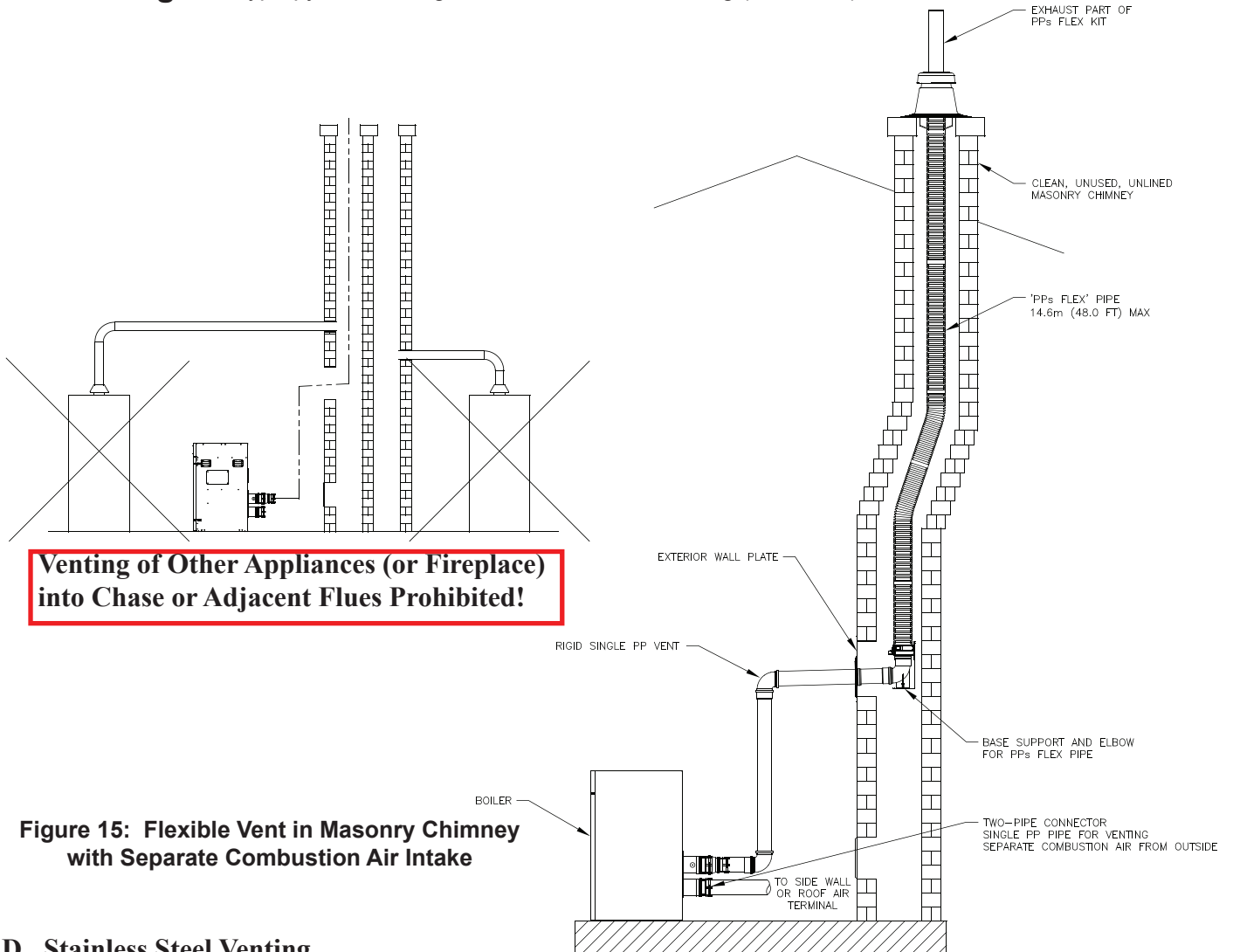

Figure 15: Flexible Vent in Masonry Chimney with Separate Combustion Air Intake

D. Stainless Steel Venting

WARNING

Asphyxiation Hazard. Follow these instructions and the installation instructions included by the original stainless steel venting component manufacturers, Heat Fab, M&G/DuraVent or Z-Flex, whichever applicable. Failure to do so could cause products of combustion to enter the building, resulting in severe property damage, personal injury or death. Where a conflict arises between Heat Fab, M&G/DuraVent or Z-Flex instructions and these instructions, the more restrictive instructions shall govern.

Do not mix vent components from listed manufacturers.

Examine all components for possible shipping damage prior to installation.

All condensate that forms in the vent must be able to drain back to the boiler.

NOTICE

Do not exceed maximum vent/combustion air system length. Refer to “2. Vent/Combustion Air Piping” under “A. General Guidelines” in this section for maximum vent/combustion air system length.

Use only vent and combustion air terminals and terminal locations shown in “3. Vent/Combustion Air Terminals” under “A. General Guidelines” of this section.

1. Components

- a. For use on models APX425 and APX525, Thermal Solutions offers size 4 in. vent pipe and fittings shown in Table 11A. It is the responsibility of the installing contractor to procure stainless steel vent system pipe and related components.
- b. Alternate listed stainless steel vent system manufacturers and components are shown in Table 11B.

IV. Venting D. Stainless Steel Venting (continued)

Table 11A: Thermal Solutions Vent System Components (Stainless Steel, 4 in. only)

Vent System Component	Part Numbers	Equivalent Length of Pipe
	APX425 and APX525	
	4 In. Vent	
SS Vent Kit	102501-02	N/A
Horizontal Vent Terminal (Included in Kit)	8116313	
PVC to SS Vent Adapter (Included In Kit)	102220-01	
Vertical Vent Terminal	102680-02	
Pipe x 1 ft. (0.3 m)	100176-01	
Pipe x 3 ft. (0.9 m)	100177-01	3 ft. (0.9 m)
Pipe x 5 ft. (1.5 m)	100178-01	5 ft. (1.5 m)
Pipe x Adjustable	100179-01	Equal to Installed Length 1.06 to 1.64 ft. (0.3 m to 0.5 m)
90° Elbow	100180-01	8 ft. (2.4 m)
45° Elbow	100181-01	4.5 ft. (1.4 m)
Horizontal Drain Tee	100182-01	2 ft. (0.6 m)
Vertical Drain Tee	100183-01	7.5 ft. (2.3 m)
Single Wall Thimble	100184-01	N/A

- c. Where the use of “silicone” is called for in the following instructions, use GE RTV 106 or equivalent for the vent collar. Seal galvanized combustion air piping sections with any general-purpose silicone sealant such as GE RTV102. Seal PVC combustion air piping sections with PVC cement.
- d. Do not drill holes in vent pipe.

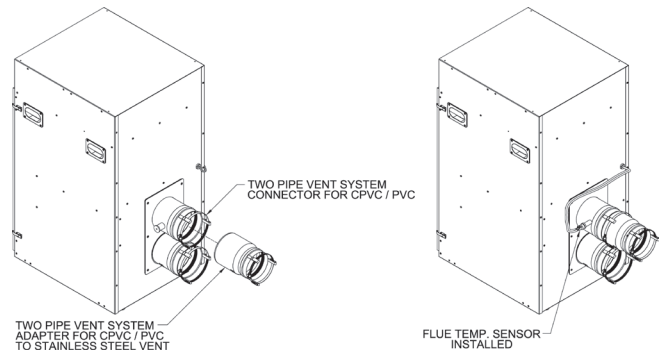

Figure 16: Field Installation of Two-Pipe Vent System Adapter for Stainless Steel

2. Field Installation of CPVC/PVC Two-Pipe Vent System Connector and PVC to Stainless Steel Adapter

- a. Install CPVC/PVC two-pipe vent system connector. Follow instructions in “2. Field Installation of CPVC/PVC Two-Pipe Vent System Connector” under “B. CPVC/PVC Venting.” See also Figures 9 and 16.
- b. Models APX425 and APX525 only: Apply provided dielectric grease (grease pouch taped to the vent system connector) all around to the vent or air connection inner red silicon gasket.
- c. Models APX625, APX725 and APX825 only: Apply a coating of supplied red RTV silicone sealant, at least 1 in. (25 mm) wide, around circumference of PVC to stainless steel adapter (P/N 103285-01) male end.
- d. Push and twist 6 in. PVC to stainless steel adapter (P/N 103285-01) into two-pipe vent system connector vent or combustion air supply port until bottomed out. See Figure 16.
- e. Tighten the worm band clamp screw to secure PVC to stainless steel adapter.
- f. Do not install PVC to stainless steel adapter at the lower combustion air supply port of the two-pipe vent system connector when using PVC pipe for combustion air supply to boiler.

Table 11B: Alternate Vent Systems and Vent Components (Stainless Steel)

Manufacturer	Vent System	Nominal Dia.	PVC to SS Adapter	Wall Thimbles	Horizontal Termination	Vertical Termination
M&G/DuraVent	FasNseal	4 in. (100 mm)	810005231	FSWT4	Tee: FSTT4	FSBS4
		6 in. (150 mm)	810005545	FSWT6	Tee: FSTT6	FSBS6
Z-Flex	SVE Series III (“Z-Vent III”)	4 in. (100 mm)	2SVSTTA04.5	2SVSWTF04	Tee: 2SVSTTX04	2SVSTPX04
		6 in. (150 mm)	2SVSTTA06.5	2SVSWTF06	Tee: 2SVSTTX06	2SVSTPX06

NOTE: See vent system manufacturer’s literature for other part numbers that are required such as straight pipe, elbows, firestops and vent supports.

IV. Venting D. Stainless Steel Venting (continued)

3. System Assembly



WARNING

Asphyxiation Hazard. Vent systems made by Heat Fab, M&G / DuraVent and Z-Flex rely on gaskets for proper sealing. When these vent systems are used, take the following precautions:

- **Make sure that gasket is in position and undamaged in the female end of the pipe.**
- **Make sure that both the male and female pipes are free of damage prior to assembly.**
- **Only cut vent pipe as permitted by the vent manufacturer in accordance with their Instructions. When pipe is cut, cut end must be square and carefully de-burred prior to assembly.**

- a. Plan venting system to avoid possible contact with plumbing or electrical wires. Start at vent connector at boiler and work towards vent termination.
- b. Follow all manufacturer instructions and warnings when preparing pipe ends for joining and when assembling the vent/combustion air system.

NOTICE

The venting system must be free to expand and contract and supported in accordance with installation instructions included by the original stainless steel venting component manufacturers, Heat Fab, M&G / DuraVent or Z-Flex, whichever applicable.

- c. On horizontal pipe sections, orient all welded seams at the 12:00 position. Do not place longitudinal welded seams at the bottom of horizontal sections of vent pipe.
- d. Assemble the combustion air system using either galvanized or PVC pipe.
 - i. If PVC piping is used, use PVC cement to assemble the PVC intake system components. See “B. CPVC/PVC Venting” for combustion air pipe installation instructions.
 - ii. If galvanized piping is used, use at least two sheet metal screws per joint. Seal outside of all joints

4. Horizontal Sidewall Vent Termination

- a. Standard Two-Pipe Termination
See Figures 5A and 5B.

- i. Vent Termination

- Use a stainless steel tee in the upright position.

NOTICE

The joint between the terminal and the last piece of pipe must be outside of the building.

- Male end of terminal will fit into female end of any of the listed stainless vent systems.
- Apply a heavy bead of silicone to the male end of the terminal before inserting it into the last piece of pipe. Orient the terminal so that the seam in the terminal is at 12:00.
- Smooth the silicone over the seam between the terminal and the last piece of pipe, applying additional silicone if necessary to ensure a tight seal.
- Allow the silicone to cure per the silicone manufacturer’s instructions before operating the boiler.

- ii. Combustion Air Termination

- Use a tee in the upright position. Tee should protrude the same distance from the wall as the exhaust terminal as shown in Figure 5A.
- Install a rodent screen (not supplied) in the inlet terminal. Use a screen having 1/2 in. x 1/2 in. (13 mm x 13 mm) mesh.

- b. Optional Two-Pipe Snorkel Termination

See Figures 6A and 6B.

This installation will allow a maximum of 7 ft. (2.1 m) vertical exterior run of the vent/combustion air piping to be installed on the approved AL29-4C stainless steel horizontal venting application.

- i. Vent Termination

- After penetrating wall, install the appropriate manufacturer’s 90° elbow so that the elbow leg is in the up direction.
- Install maximum vertical run of 7 ft. (2.1 m) of appropriate manufacturer’s vent pipe as shown in Figure 6A.
- At top of vent pipe length install another appropriate manufacturer’s 90° elbow so that the elbow leg is opposite the building’s exterior surface.
- Install horizontal vent terminal.
- Brace exterior piping if required.

IV. Venting D. Stainless Steel Venting - E. Removing the Existing Boiler - F. Multiple Boiler Installation Venting (continued)

- ii. Combustion Air Termination
 - After penetrating wall, install a 90° elbow so that the elbow leg is in the up direction.
 - Install maximum vertical run of 7 ft. (2.1 m) of combustion air pipe as shown in Figure 6B.
 - At top of vent pipe length install another 90° elbow so that the elbow leg is opposite the building's exterior surface.
 - Install rodent screen (not supplied) and horizontal vent terminal.
 - Brace exterior piping if required.

5. Vertical Vent Termination

a. Standard Two-Pipe Termination

See Figures 7 and 8.

- i. Vent Termination
 - Use the terminal supplied by the vent system manufacturer shown in Table 11B. Follow manufacturer's instructions to attach terminal to vent system.
- ii. Combustion Air Termination
 - Install vertical combustion air terminal. Vertical combustion air terminal consists of a 180° bend (comprised of two 90° elbows) as shown in Figure 7.
 - Install rodent screen (not supplied) in the combustion air terminal. Use a screen having 1/2 in. x 1/2 in. (13 mm x 13 mm) or larger mesh.

E. Removing the Existing Boiler

When an existing boiler is removed from a common venting system, the common venting system is likely to be too large for proper venting of the remaining appliances. At the time of removal of an existing boiler, the following steps shall be followed with each appliance remaining connected to the common venting system placed in operation, while the other appliances remaining connected to the common venting system are not in operation.

1. Seal any unused openings in the common venting system.
2. Visually inspect the venting system for proper size and horizontal pitch and determine there is no blockage or restriction, leakage, corrosion, and other deficiencies which could cause an unsafe condition.
3. Insofar as is practical, close all building doors and windows and all doors between the space in which the appliances remaining connected to the common venting system are located and other spaces of the

building. Turn on clothes dryers and any appliance not connected to the common venting system. Turn on any exhaust fans, such as range-hoods and bathroom exhausts, so they will operate at maximum speed. Do not operate a summer exhaust fan. Close fireplace dampers.

4. Place in operation the appliance being inspected. Follow the Lighting (or Operating) Instructions. Adjust thermostat so appliance will operate continuously.
5. Test for spillage at the draft hood relief opening after 5 minutes of main burner operation. Use the flame of a match or candle, or smoke from a cigarette, cigar or pipe.
6. After it has been determined that each appliance remaining connected to the common venting system properly vents when tested as outlined above, return doors, windows, exhaust fans, fireplace dampers and any other gas burning appliance to their previous conditions of use.
7. Any improper operation of the common venting system should be corrected so the installation conforms with the *National Fuel Gas Code*, ANSI Z223.1/NFPA 54 and/or the *Natural Gas and Propane Installation Code*, CAN/CSA B149.1. When resizing any portion of the common venting system, the common venting system should be resized to approach the minimum size as determined using the appropriate tables in Part II in the *National Fuel Gas Code*, ANSI Z223.1/NFPA 54 and/or the *Natural Gas and Propane Installation Code*, CAN/CSA B149.1.

Au moment du retrait d'une chaudière existante, les mesures suivantes doivent être prises pour chaque appareil toujours raccordé au système d'évacuation commun et qui fonctionne alors que d'autres appareils toujours raccordés au système d'évacuation ne fonctionnent pas:

1. Sceller toutes les ouvertures non utilisées du système d'évacuation.
2. Inspecter de façon visuelle le système d'évacuation pour déterminer la grosseur et l'inclinaison horizontale qui conviennent et s'assurer que le système est exempt d'obstruction, d'étranglement, de fuite, de corrosion et autres défaillances qui pourraient présenter des risques.
3. Dans la mesure du possible, fermer toutes les portes et les fenêtres du bâtiment et toutes les portes entre l'espace où les appareils toujours raccordés au système d'évacuation sont installés et les autres espaces du bâtiment. Mettre en marche les sècheuses, tous les appareils non raccordés au système d'évacuation commun

IV. Venting F. Multiple Boiler Installation Venting (continued)

et tous les ventilateurs d'extraction comme les hottes de cuisinière et les ventilateurs des salles de bain. S'assurer que ces ventilateurs fonctionnent à la vitesse maximale. Ne pas faire fonctionner les ventilateurs d'été. Fermer les registres des cheminées.

4. Mettre l'appareil inspecté en marche. Suivre les instructions d'allumage. Régler le thermostat de façon que l'appareil fonctionne de façon continue.
5. Faire fonctionner le brûleur principal pendant 5 min ensuite, déterminer si le coupe-tirage déborde à l'ouverture de décharge. Utiliser la flamme d'une allumette ou d'une chandelle ou la fumée d'une cigarette, d'un cigare ou d'une pipe.
6. Une fois qu'il a été déterminé, selon la méthode indiquée ci-dessus, que chaque appareil raccordé au système d'évacuation est mis à l'air libre de façon adéquate. Remettre les portes et les fenêtres, les ventilateurs, les registres de cheminées et les appareils au gaz à leur position originale.
7. Tout mauvais fonctionnement du système d'évacuation commun devrait être corrigé de façon que l'installation soit conforme au National Fuel Gas Code, ANSI Z223.1/NFPA 54 et (ou) aux codes d'installation CAN/CSA-B149.1. Si la grosseur d'une section du système d'évacuation doit être modifiée, le système devrait être modifié pour respecter les valeurs minimales des tableaux pertinents de l'appendice F du National Fuel Gas Code, ANSI Z223.1/NFPA 54 et (ou) des codes d'installation CAN/CSA-B149.1.

F. Multiple Boiler Installation Venting

1. Vent Piping and Terminations

- a. Multiple boiler vent terminations are shown in Figure 17.
- b. Each individual boiler must have its own vent pipe and vent terminal. Refer to Paragraphs A through E (as applicable) for individual boiler vent guidelines and options.



WARNING

Asphyxiation Hazard. No common manifold venting (vent piping and vent terminals) is permitted.

- c. Do not exceed the individual boiler maximum vent length listed in Table 5.

- d. For horizontal sidewall terminations, maintain at least 12 in. (300 mm) minimum horizontal distance between any adjacent individual boiler vent terminations. Additional horizontal spacing between any adjacent individual boiler vent terminations as well as extending the distance from building surfaces to vent termination end are recommended to avoid frost damage to building surfaces where vent terminations are placed.

NOTICE

Installing multiple individual boiler vent terminations too close together may result in combustion product water vapor condensation on building surfaces, where vent terminations are placed, and subsequent frost damage. To avoid/minimize frost damage, extend the distance from building surfaces to vent termination end and increase the horizontal distance between adjacent vent terminations.

- e. Individual boiler sidewall vent terminals must be placed at least 12 in. (300 mm) [18 in. (460 mm) in Canada] above the ground plus the expected snow accumulation.
- f. Multiple individual boiler vertical vent pipes may be piped through a common conduit or chase so that one roof penetration may be made.
- g. For vertical roof terminations, maintain at least 12 in. (300 mm) minimum horizontal distance between adjacent individual boiler vent terminations.

2. Combustion Air Piping

- a. Multiple boiler combustion air terminations are shown in Figure 17.
- b. Each individual boiler must have own combustion air pipe and terminal. Refer to Paragraphs A through E (as applicable) for individual boiler combustion air guidelines and options.
- c. Do not exceed the individual boiler maximum combustion air pipe length listed in Table 5.
- d. If possible, locate vent and combustion air terminals for an individual boiler on the same wall to prevent nuisance shutdowns. If not, an individual boiler may be installed with a roof vent terminal and sidewall combustion air terminal.

34 IV. Venting F. Multiple Boiler Installation Venting (continued)

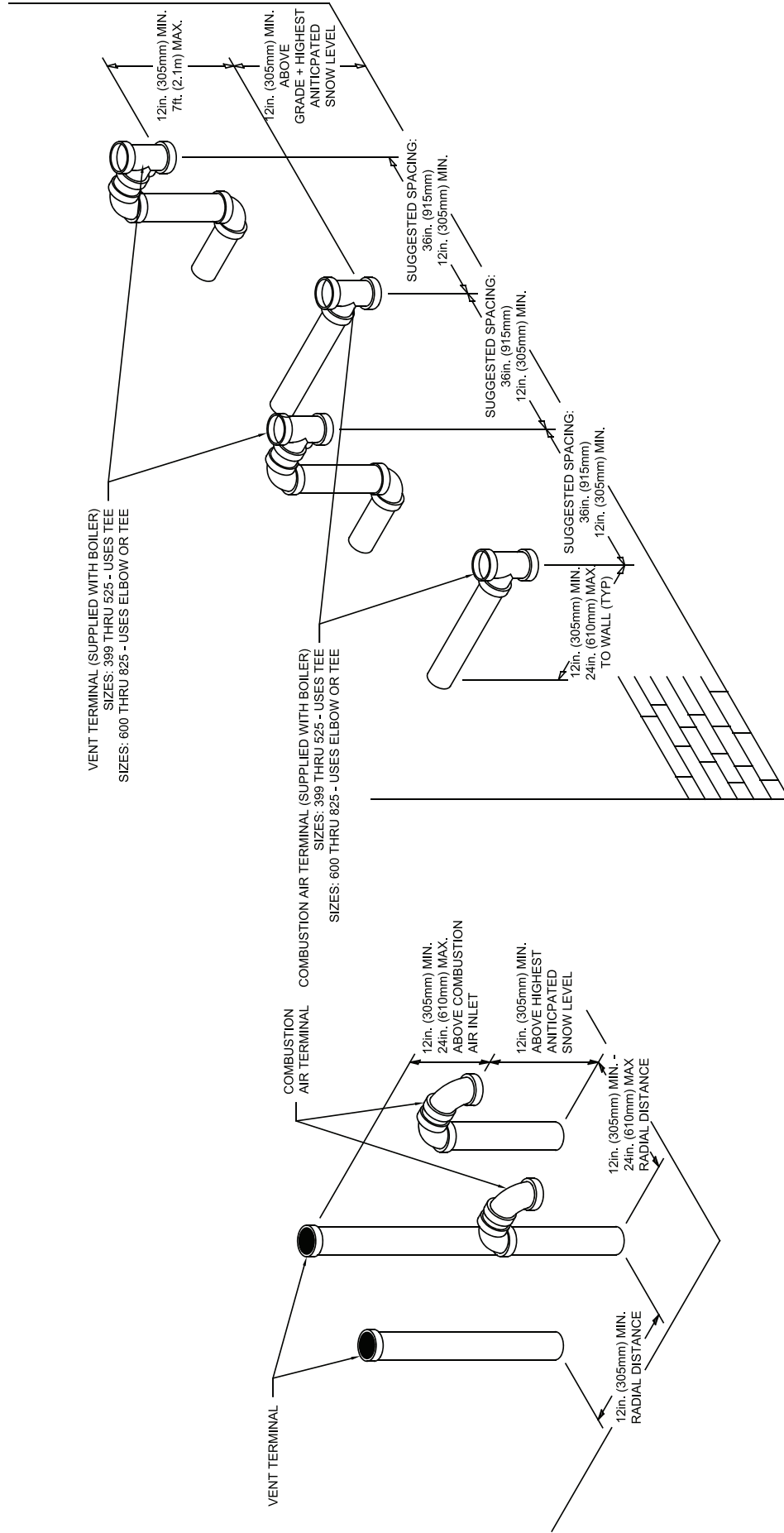

Figure 17: Multiple Boiler Direct Vent Termination

V. Condensate Disposal

A. Condensate Trap and Drain Line

1. All condensate which forms in the boiler or vent system collects in the sump under heat exchanger and leaves the boiler through factory installed condensate trap.
2. The trap allows condensate to drain from sump while retaining flue gases in the boiler. The trap has factory installed overflow switch, which shuts down the boiler in the event the drain line becomes obstructed, preventing proper condensate removal. Refer to Section XI "Service and Maintenance" for condensate trap and condensate overflow switch removal and replacement procedure, if required.
3. Note the following when disposing of the condensate:
 - a. Condensate is slightly acidic, typical pH around 3.5 - 4.5. Do not use metallic pipe or fittings in the condensate drain line. Do not route the drain line through areas that could be damaged by leaking condensate.
 - b. Do not route or terminate the condensate drain line in areas subject to freezing temperatures.
 - c. If the point of condensate disposal is above the trap, a condensate pump is required to move the condensate to the drain. Select a condensate pump approved for use with condensing furnaces. If overflow from the pump would result in property damage, select a pump with an overflow switch. Wire this switch in series with installer provided external high limit, to shut off the boiler, and, if desired, in series with installer-supplied alarm, to trigger an alarm in the event of overflow.
 - d. Do not attempt to substitute another trap for one provided with the boiler.
 - e. In order for boiler to work properly, the boiler must be leveled during installation.
4. The condensate trap connection is located at boiler left side, below inlet and outlet water pipe connections. Refer to Figures 1A, 1B, 1C, 1D and 18.
5. Condensate trap must be filled up with water, prior to boiler start-up and before connecting any condensate line to the boiler to insure combustion products cannot escape from operating boiler. To fill the trap, inject water in the amount of 1 cup (240ml) through condensate trap connection. Do not overfill the trap.
6. Install tee for condensate overflow and vent as shown in Figure 18.



WARNING

Asphyxiation Hazard. Failure to fill the condensate trap with water prior to boiler start-up could cause flue gas to enter the building, resulting in personal injury or death.

7. If any additional condensate drain line is needed, construct the extension from PVC or CPVC Schedule 40 pipe. The factory supplied $\frac{3}{4}$ in. x 5-5/8 in. long PVC coupling, located in the miscellaneous parts carton, must be used to connect drain line to the condensate trap. Do not over tighten coupling compression nuts when connecting drain line and condensate trap.
8. Size condensate drain line, pump and neutralizer (if using other than manufacturer neutralizer kit) to accommodate maximum condensate flow shown in Table 11C "Maximum Condensate Flow".

Table 11C: Maximum Condensate Flow

Boiler Model	*Maximum Condensate Flow, GPH
APX425	4.5
APX525	5.6
APX625	7.0
APX725	8.1
APX825	9.0

*Assumes 100% of water in fuel condensates.



WARNING

Asphyxiation Hazard. Failure to install the condensate drain in accordance with the above instructions could cause flue gas to enter the building, resulting in personal injury or death.

NOTICE

Boiler condensate is corrosive. Route condensate drain line in a manner such that any condensate leakage will not cause property damage.

Some jurisdictions may require that condensate be neutralized prior to disposal.

Use materials approved by the authority having jurisdiction.

V. Condensate Disposal (continued)

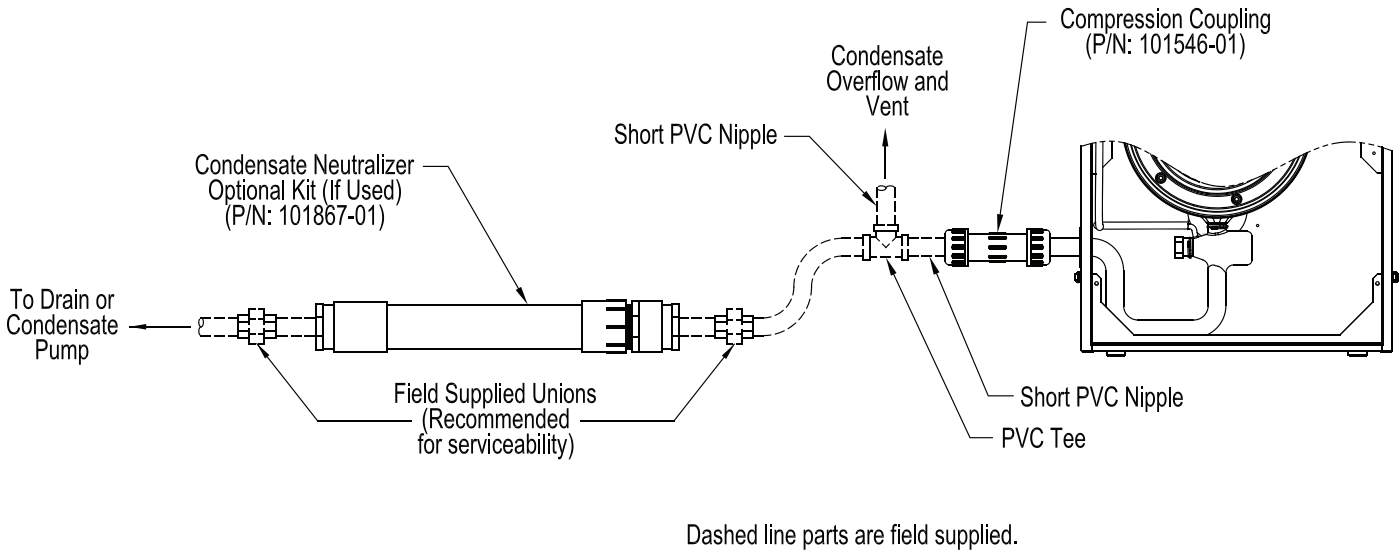

Figure 18: Condensate Trap and Drain Line

B. Condensate Neutralizer Installation

1. Some jurisdictions may require that the condensate be neutralized before being disposed of. Follow local codes pertaining to condensate disposal.
2. A condensate neutralizer kit (P/N 101867-01) is available as optional equipment. Follow local codes and instructions enclosed with the kit for condensate neutralizer installation.
3. Limestone chips will get coated by neutral salts (product of chemical reaction between limestone and acidic condensate) and lose neutralizing effectiveness over time. Therefore, periodic condensate neutralizer maintenance and limestone chip replacement must be performed. A pH test or acid test kits are available from HVAC/plumbing distributors and should be used to measure condensate acidity before/after neutralizer thus indicating a need for service and chip replacement.

VI. Water Piping and Trim

NOTICE

Failure to properly pipe boiler may result in improper operation and damage to boiler or structure.

Install boiler so that the gas ignition system components are protected from water (dripping, spraying, rain, etc.) during appliance operation and service (circulator replacement, etc.).

Oxygen contamination of boiler water will cause corrosion of iron and steel boiler components, and can lead to boiler failure. Thermal Solutions' Standard Warranty does not cover problems caused by oxygen contamination of boiler water or scale (lime) build-up caused by frequent addition of water.

Do not fill boiler with softened water to prevent chloride contamination.

Installation is not complete unless a safety relief valve is installed into the tapping located on left side of appliance or the supply piping.

A. Installation of Factory Supplied Piping and Trim Components

Apex boilers have factory supplied Miscellaneous Parts Carton, which includes packaged flow switch with two boiler-specific paddles, supply piping components, gas piping components, temperature & pressure gauge, safety relief valve and drain valve. See Figure 19A, 19B or 19C "Factory Supplied Piping and Trim Installation".

Install these components prior to connecting boiler to system piping as follows:

Boiler Model	Miscellaneous Parts Carton
APX425	102942-05
APX525	
APX625	104520-01
APX725	
APX825	103259-02

1. Models APX425 and APX525 (see Figure 19A "Factory Supplied Piping and Trim Installation - APX425 and APX525")

- Locate and remove $\frac{3}{4}$ in. NPT x close black nipple, $\frac{3}{4}$ in. NPT x 10 in. black nipple, $\frac{3}{4}$ in. NPT black tee, $\frac{3}{4}$ in. FPT x $\frac{3}{4}$ in. FPT safety relief valve and $\frac{3}{4}$ in. NPT drain valve.
- Install close nipple into tee branch. Then, screw the assembly into boiler left side front $\frac{3}{4}$ in. FPT tapping, making sure tee run outlets are in vertical plane and parallel to boiler side.
- Install the $\frac{3}{4}$ in. NPT x 10 in. black nipple into tee run top outlet.
- Mount $\frac{3}{4}$ in. FPT x $\frac{3}{4}$ in. FPT safety relief valve onto 10 in. nipple.

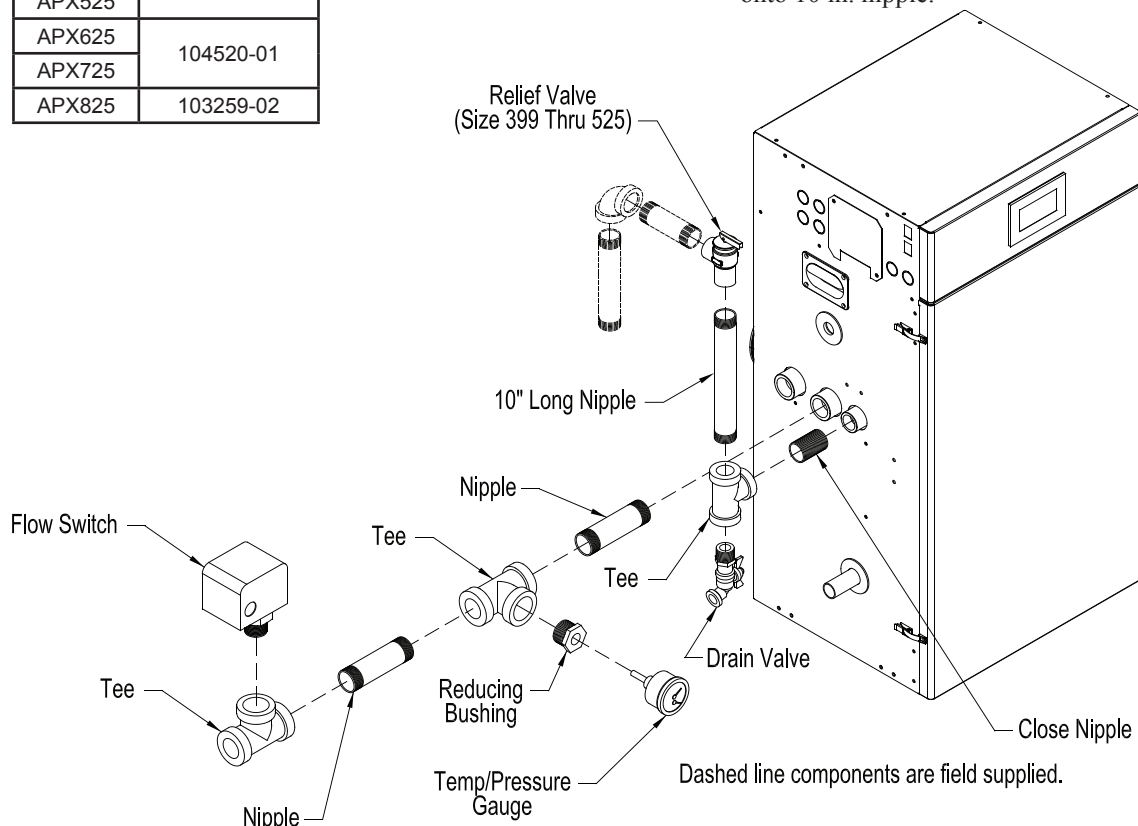

Figure 19A: Factory Supplied Piping and Trim Installation - APX425 and APX525

VI. Water Piping and Trim A. Factory Supplied Piping and Trim (continued)

- e. Install drain valve into tee bottom outlet.
- f. Locate and remove (2) 1½ in. NPT x 2 in. long black nipples, 1½ in. x 1½ in. x ¾ in. NPT black tee, 1½ in. x 1½ in. x 1 in. NPT black tee, packaged flow switch with paddles, ¾ in. x ¾ in. NPT black reducing bushing and temperature & pressure gauge.
- g. Mount (1) 1½ in. NPT 2 in. long nipple into 1½ in. FPT boiler supply tapping (see Figures 1A and 1B). Then, install 1½ in. x 1½ in. x ¾ in. NPT tee onto the nipple, making sure ¾ in. branch outlet is in horizontal plane and facing the boiler front.
- h. Install ¾ in. x ¼ in. NPT black reducing bushing into the tee branch. Then, put in temperature & pressure gauge.
- i. Install second 1½ in. NPT x 2 in. long nipple into 1½ in. x 1½ in. x ¾ in. NPT tee run.
- j. Mount 1½ in. x 1½ in. x 1 in. NPT black tee onto the nipple, making sure tee 1 in. NPT branch outlet is in upright position.
- k. Remove flow switch and paddles from packaging carton. Also see/follow Taco Instruction Sheet for Flow Switch Kit (supplied with the flow switch) for specific details.
- l. Select the paddle stamped “1” for the APX425 and APX525.
- m. Attach paddle to flow switch stem using supplied machine screw.
- n. Apply pipe dope to the switch-threaded brass-bushing end. Then, mount the switch threaded end with the attached paddle into 1-1/2 in. x 1-1/2 in. x 1 in. NPT tee branch and tighten such that distance between bottom of switch housing and top of tee branch is approximately 1-11/16 in. (43 mm). Insure the switch paddle is positioned perpendicular to the flow direction for the best flow sensitivity. Do not tighten the switch by grasping the switch enclosure. Use the wrenching flats on the bushing only. The turning radius required for the switch mounting is 3 in. (80 mm).
- o. For flow switch wiring refer to Section VIII “Electrical” of these instructions.

2. Models APX625 and APX725 (see Figure 19B, “Factory Supplied Piping and Trim Installation – APX625 and APX725”)

- a. Locate 2 in. x 2 in. x ¾ in. NPT black tee, ¾ in. NPT x close black nipple, and ¾ in. NPT black tee. Install close nipple in branch of 2 in. x 2 in. x ¾ in. NPT tee. Install branch of ¾ in. NPT tee onto other end of close nipple. Install 2 in. x 2 in. x ¾ in. NPT tee onto 2 in. MPT supply connection at front of boiler, making sure branch of 2 in. x 2 in. x ¾ in. NPT tee is oriented towards front of boiler and run of ¾ in. NPT tee is oriented vertically.

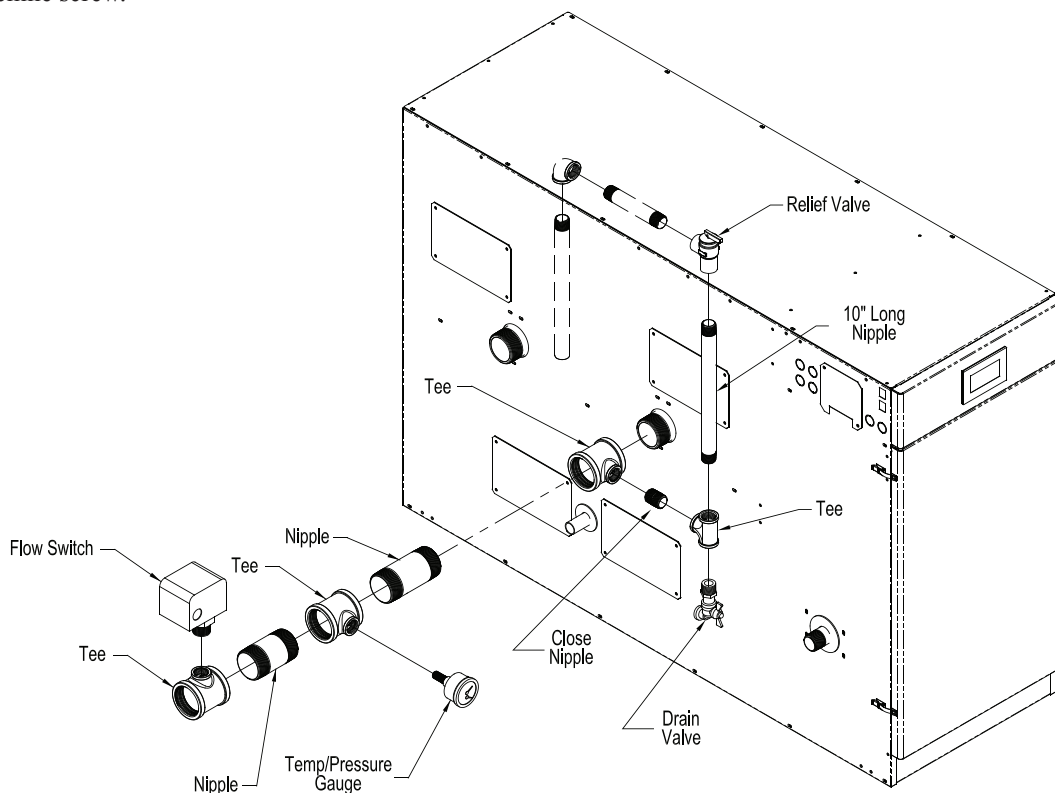

Dashed line components are field supplied.

Figure 19B: Factory Supplied Piping and Trim Installation - APX625 and APX725

VI. Water Piping and Trim A. Factory Supplied Piping and Trim (continued)

- b. Locate 3/4 in. NPT x 10 in. black nipple, 3/4 in. FPT x 1 in. FPT safety relief valve, and 3/4 in. NPT drain valve. Install nipple in top run of 3/4 in. NPT tee connected to supply in Step a. Mount safety relief valve onto nipple. Install drain valve in bottom run of 3/4 in. NPT tee connected to Supply in Step a.
- c. Locate 2 in. x 2 in. x 1/2 in. NPT black tee, one 2 in. NPT x 2-1/2 in. black nipple, and 1/2 in. NPT temperature and pressure gage. Install nipple into 2 in. x 2 in. x 3/4 in. NPT tee installed in Step a. Install 2 in. x 2 in. x 1/2 in. NPT tee onto nipple, making sure branch is oriented towards front of boiler. Then, install temperature and pressure gage onto tee branch.
- d. Locate 2 in. x 2 in. x 1 in. NPT black tee and second 2 in. NPT x 2-1/2 in. black nipple. Install nipple into 2 in. x 2 in. x 1/2 in. NPT tee installed in Step c. Install 2 in. x 2 in. x 1 in. NPT tee onto nipple, making sure branch is oriented upward.
- e. Locate flow switch kit. Remove flow switch and paddles from packaging carton. See Taco Instruction Sheet for Flow Switch Kit (supplied with flow switch) for specific details.
- f. For APX625, select paddle stamped “3”.
- g. For APX725, select paddle stamped “1”.
- h. Attach paddle to flow switch stem using supplied machine screw.
- i. Apply pipe dope to flow switch at threaded brass-bushing end. Then, mount the switch threaded end with attached paddle into 2 in. x 2 in. x 1 in. NPT tee branch and tighten such that distance between bottom of switch housing and top of tee branch is approximately 1-11/16 in. (43 mm). Insure switch paddle is positioned perpendicular to flow direction for best flow sensitivity. Do not tighten switch by grasping switch enclosure. Use wrenching flats on bushing only. The turning radius required for switch mounting is 3 in. (80 mm).
- j. For flow switch wiring, refer to Section VIII “Electrical” of these instructions.

3. Model APX825 (see Figure 19C “Factory Supplied Piping and Trim Installation - APX825”)

- a. Locate and remove 3/4 in. NPT x close black nipple, 3/4 in. NPT x 10 in. black nipple, 3/4 in. NPT black tee, 3/4 in. FPT x 1 in. FPT safety relief valve and 3/4 in. NPT drain valve.

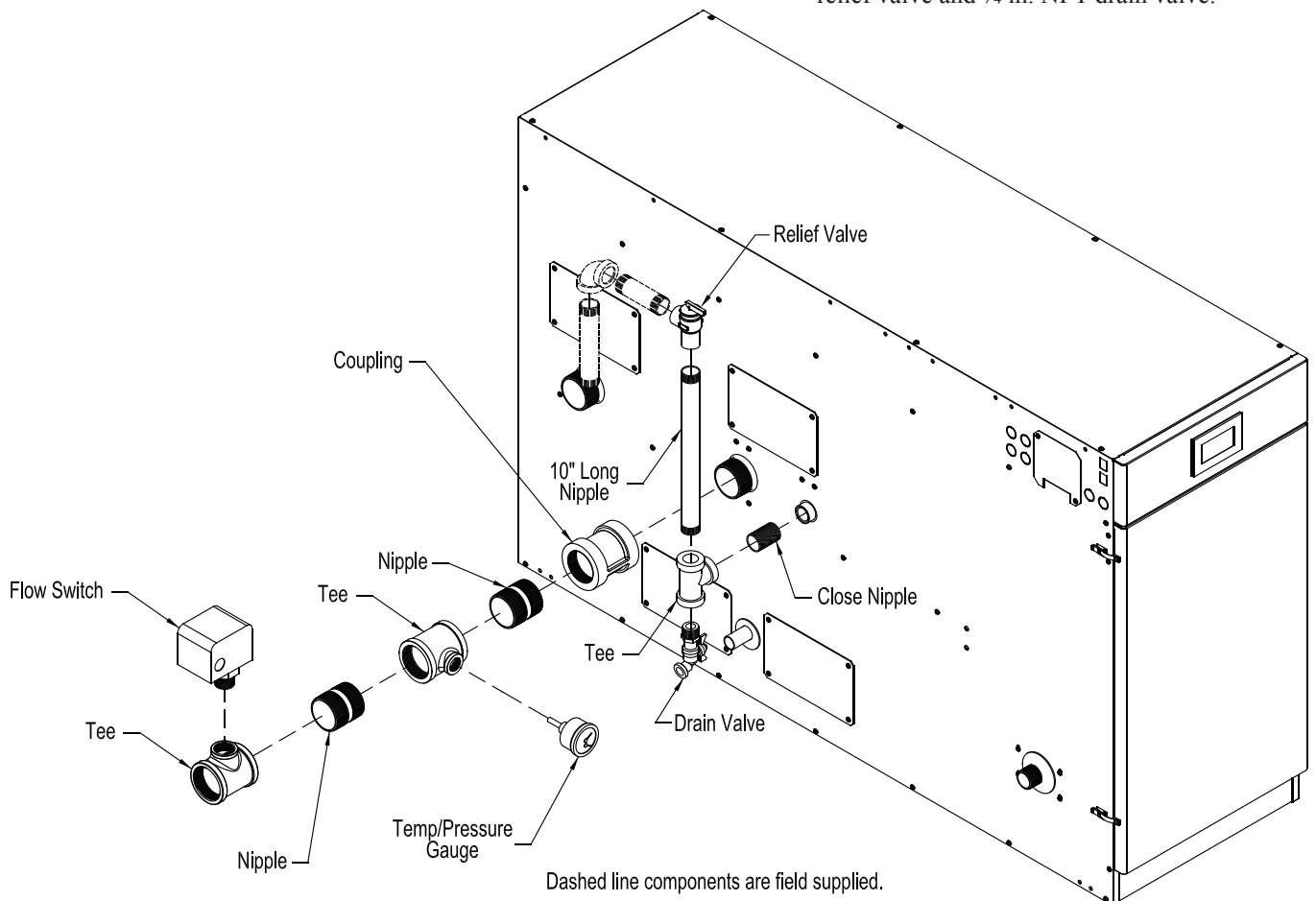

Figure 19C: Factory Supplied Piping and Trim Installation - APX825

VI. Water Piping and Trim A. Factory Supplied Piping and Trim (continued)

- b. Install close nipple into tee branch. Then, screw the assembly into boiler left side 3/4 in. front tapping, making sure tee run outlet is in vertical plane and parallel to boiler side.
- c. Install the 3/4 in. NPT x 10 in. black nipple into tee top run outlet.
- d. Mount 3/4 in. FPT x 1 in. FPT safety relief valve onto 10 in. nipple.
- e. Install drain valve into tee bottom run outlet.
- f. Locate and remove 2 in. NPT steel coupling, (2) 2 in. NPT x 2-1/2 in. long black nipples, 2 in. x 2 in. x 1/2 in. NPT black tee, 2 in. x 2 in. x 1 in. NPT black tee, packaged flow switch with paddles, and temperature & pressure gauge.
- g. Mount 2 in. NPT coupling onto 2 in. MPT boiler supply tapping (see Figure 1C). Then, install 2 in. NPT x 2-1/2 in. long black nipple into the coupling outlet. Attach 2 in. x 2 in. x 1/2 in. tee onto the nipple opposite end, making sure 1/2 in. branch outlet is in horizontal plane and facing the boiler front.
- h. Install temperature & pressure gauge into the tee branch.
- i. Install second 2 in. NPT x 2 1/2 in. long nipple into 2 in. x 2 in. x 1/2 in. NPT tee run.
- j. Mount 2 in. x 2 in. x 1 in. NPT black tee onto the nipple, making sure tee 1 in. NPT branch outlet is oriented upward.
- k. Remove flow switch and paddles from packaging carton. Also see/follow Taco Instruction Sheet for Flow Switch Kit (supplied with flow switch) for specific details.
- l. Select paddle stamped "1" for APX825.
- m. Attach paddle to flow switch stem using supplied machine screw.
- n. Apply pipe dope to the switch-threaded brass-bushing end. Then, mount the switch threaded end with the attached paddle into 2 in. x 2 in. x 1 in. NPT tee branch and tighten such that distance between bottom of switch housing and top of tee branch is approximately 1-11/16 in. (43 mm). Insure the switch paddle is positioned perpendicular to the flow direction for the

Table 12: Flow Range Requirement Through Boiler

Boiler Model	Supply Connection (in.)	Return Connection (in.)	$\Delta T = 35^{\circ}F$		$\Delta T = 30^{\circ}F$		$\Delta T = 25^{\circ}F$		$\Delta T = 20^{\circ}F$	
			Minimum Required Flow (GPM)	Boiler Head Loss (ft.)	Required Flow (GPM)	Boiler Head Loss (ft.)	Required Flow (GPM)	Boiler Head Loss (ft.)	Maximum Required Flow (GPM)	Boiler Head Loss (ft.)
APX425	1-1/2	1-1/2	21.5	6.1	25.1	7.9	30.2	10.8	37.7	15.9
APX525	1-1/2	1-1/2	27.1	6.9	31.7	8.9	38.0	12.1	47.5	17.6
APX625	2	2	33.9	4.7	39.6	6.1	47.5	8.4	59.4	12.4
APX725	2	2	39.4	6.0	45.9	7.9	55.1	10.9	68.9	16.1
APX825	2	2	43.4	12.1	50.7	15.5	60.8	20.9	76.0	30.0

Notes: Required Flow = Output*1000/(500* ΔT), where flow rate is in GPM, output is in MBH, and ΔT is in $^{\circ}F$

Outputs for specific boiler models are provided in Table 2. See also Tables 13 A and 13B for near boiler piping sizing. Using boiler antifreeze will result in increased fluid density and may require larger circulators.

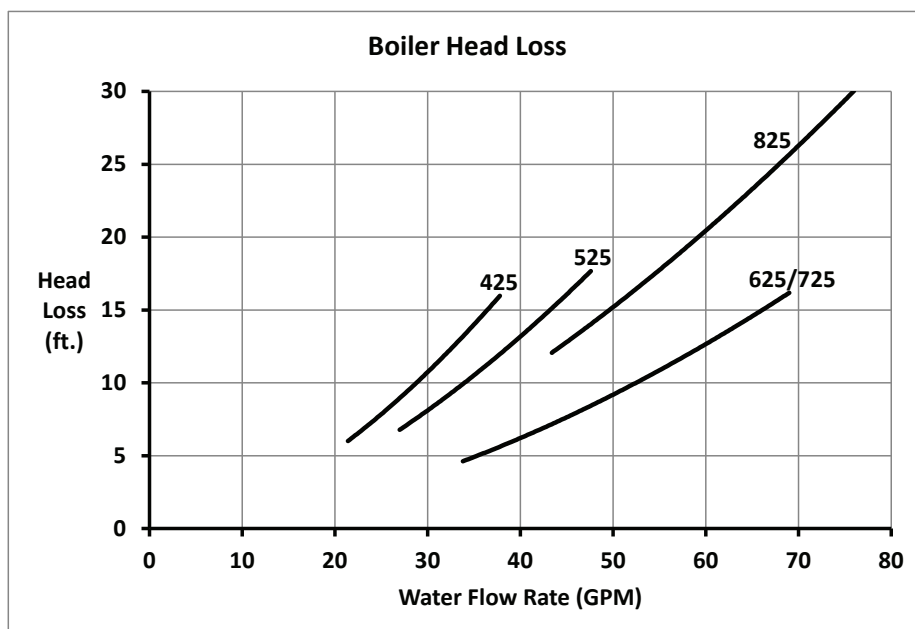

VI. Water Piping and Trim B. Piping System To Be Employed (continued).

best flow sensitivity. Do not tighten the switch by grasping the switch enclosure. Use the wrenching flats on the bushing only. The turning radius required for the switch mounting is 3 in. (80 mm).

- o. For flow switch wiring refer to Section VIII “Electrical” of these instructions.

B. Piping System To Be Employed.

Apex boilers are designed to operate in a closed loop pressurized system. Minimum pressure in the boiler must be 14.5 psi (100 kPa). Proper operation of the Apex boiler requires that the water flow through the boiler remain within the limits shown in Table 12 any time the boiler is firing.

NOTICE

Failure to maintain the flow through boiler within specified limits could result in erratic operation or premature boiler failure.

1. Near boiler piping must isolate Apex boiler from system piping via closely spaced tees to insure specified flow range through boiler any time the boiler is firing.

- a. The flow rate through the isolated near-boiler loop is maintained by installer supplied boiler circulator. See Tables 13A and 13B for recommended circulators.
- b. The flow rate through the isolated near-boiler loop is completely independent of the flow rate through the heating system loop(s).
- c. The flow rate through the heating system loop(s) is controlled by installer sized/provided system loop circulator(s).
- d. This piping arrangement can be used either for space heating-only applications or space heating with indirect water heater(s) applications.
 - i. Space heating only - refer to Tables 13A and 13B and Figure 20 “Near Boiler Piping - Heating Only” as applicable.
 - ii. Space heating plus indirect water heater(s) – refer to Tables 13A and 13B and Figure 21 “Near Boiler Piping - Heating Plus Indirect Water Heater” as applicable.
 - iii. If piping indirect water heater off boiler (see Figure 22A), be sure that indirect water heater and domestic hot water circulator are sized to maintain flow through boiler within limits shown in Table 12.

NOTICE

Where it is not possible to install a separate boiler loop, the system circulator must be sized to ensure that the flow through boiler stays within the defined parameters to prevent overheating when the boiler is fired at it’s full rated input. Install a flow meter to measure the flow, or fire the boiler at full rate and ensure the boiler ΔT does not exceed 35°F (19°C).

2. Direct connection of Apex boiler to heating system, similar to a conventional boiler, is NOT RECOMMENDED because:

- a. The flow rate through system must be the same as through boiler and fall within limits specified in Table 12.
- b. Pressure drop through entire system must be known, added to pressure drop through boiler, and a circulator selected to provide required flow at total calculated pressure drop.
- c. It is often very difficult to accurately calculate the pressure drop through the system.
- d. In replacement installations, it may be nearly impossible to get an accurate measurement of piping amount and number of fittings in the system. If system is zoned, the system flow rate may drop well below recommended minimum flow when only a single zone is calling for heat.

C. Standard Installation Requirements.

Observe the following guidelines when making the actual installation of the boiler piping:

1. **Safety Relief Valve (Required)** – The safety relief valve is packaged loose with boiler and must be installed in the location shown in Figures 19A, 19B or 19C “Factory Supplied Piping and Trim Installation”. The safety relief valve must be installed with spindle in vertical position. Installation of the safety relief valve must comply with ASME Boiler and Pressure Vessel Code, Section IV. The standard factory shipped safety relief valve is set at 50 psi (340 kPa) on APX425 and APX525 and 60 psi (410 kPa) on APX625, APX725 and APX825. Optional 80 psi (550 kPa) and 100 psi (689 kPa) safety relief valve kits are available. If the safety relief valve is to be replaced, the replacement valve must have a relief capacity equal or exceeding the minimum relief valve capacity shown on the heat exchanger ASME plate. Also, when replacing the safety relief valve, verify the temperature and pressure gage meets ASME requirements for the replacement safety relief valve. Pipe the safety relief valve discharge to a location where hot water or steam will not create hazard or property damage if the valve opens.

Table 13A: Recommended Taco Circulators for 50 ft. Equivalent ft. Near Boiler Piping [Approximately 20 ft. Straight Pipe, (4) 90° Elbows, and (2) Full Port Ball Valves]

Boiler Model	Supply & Return Connection (in.)	Near Boiler Pipe Size (in.)	ΔT=35°F			ΔT=30°F			ΔT=25°F			ΔT=20°F		
			Flow (GPM)	Boiler & Piping Head Loss (ft.)	Circulator Model	Flow (GPM)	Boiler & Piping Head Loss (ft.)	Circulator Model	Flow (GPM)	Boiler & Piping Head Loss (ft.)	Circulator Model	Flow (GPM)	Boiler & Piping Head Loss (ft.)	Circulator Model
APX425	1½	2	21.5	6.4	0014	25.1	8.4	0013	30.2	11.5	2400-60	37.7	16.9	2400-70
APX525	1½	2	27.1	7.4	0013	31.7	9.6	2400-60	38.0	13.1	2400-65	47.5	19.1	2400-70
APX625	2	2	33.9	5.5	2400-60	39.6	7.2	2400-60	47.5	9.9	2400-65	59.4	14.7	2400-70
APX725	2	2	39.4	7.1	2400-65	45.9	9.4	2400-65	55.1	12.9	2400-65	68.9	19.1	1935
APX825	2	2½	43.4	12.6	2400-65	50.7	16.3	2400-70	60.8	21.9	1915	76.0	31.6	1935

Table 13B: Recommended Grundfos Circulators for 50 Equivalent ft. Near Boiler Piping [Approximately 20 ft. Straight Pipe, (4) 90° Elbows, and (2) Full Port Ball Valves]

Boiler Model	Supply & Return Connection (in.)	Near Boiler Pipe Size (in.)	ΔT=35°F			ΔT=30°F			ΔT=25°F			ΔT=20°F		
			Flow (GPM)	Boiler & Piping Head Loss (ft.)	Circulator Model	Flow (GPM)	Boiler & Piping Head Loss (ft.)	Circulator Model	Flow (GPM)	Boiler & Piping Head Loss (ft.)	Circulator Model	Flow (GPM)	Boiler & Piping Head Loss (ft.)	Circulator Model
APX425	1½	2	21.5	6.4	UP26-64F	25.1	8.4	UP26-99F	30.2	11.5	UPS43-100F, Spd. 2	37.7	16.9	UPS43-100F, Spd. 3
APX525	1½	2	27.1	7.4	UPS43-44FC, Spd. 3 or UP26-99F	31.7	9.6	UPS26-150F, Spd. 2	38.0	13.1	UPS43-100F, Spd. 3	47.5	19.1	UP43-110F
APX625	2	2	33.9	5.5	UPS43-44FC, Spd. 3	39.6	7.2	UPS43-100F, Spd. 2	47.5	9.9	UPS43-100F, Spd. 3	59.4	14.7	UPS40-80/4, Spd. 3
APX725	2	2	39.4	7.1	UPS43-100F, Spd. 2	45.9	9.4	UPS43-100F, Spd. 3	55.1	12.9	UPS40-80/4, Spd. 3	68.9	19.1	UP43-110F
APX825	2	2½	43.4	12.6	UPS43-100F, Spd. 3	50.7	16.3	UPS40-80/4, Spd. 3	60.8	21.9	UP43-110F	76.0	31.6	UPS40-240/2, Spd. 3

VI. Water Piping and Trim C. Standard Installation Requirements (continued)

The end of the discharge pipe must terminate in an unthreaded pipe. If the safety relief valve is not piped to a drain, it must terminate at least 6 in. (150 mm) above the floor. Do not run safety relief valve discharge piping through an area prone to freezing. The termination of discharge piping must be in an area where it will not become plugged by debris.



CAUTION

Burn Hazard. Safety relief valve discharge piping must be piped such that the potential of severe burns is eliminated. DO NOT pipe in any area where freezing could occur. DO NOT install any shut-off valves, plugs or caps. Consult local codes for proper discharge piping arrangement.

- 2. Flow Switch (Required)** – A flow switch is required in lieu of manual reset low water cutoff (LWCO) for forced circulation coil-type water boilers to prevent overheating and heat exchanger failure in accordance with requirements of ASME Boiler and Pressure Vessel Code, Section IV, and ANSI/ASME CSD-1 – latest edition, “Controls and Safety Devices for Automatically Fired Boilers”.

The flow switch is factory provided. Follow Section VI, Paragraph A and Section VIII ‘Electrical’ of these instructions to install and wire the flow switch.

- 3. Circulator (Required)** – Usually at least two circulators will be required to properly install an Apex boiler. See Paragraph B above for information on sizing the circulators.
- 4. Expansion Tank (Required)** – If this boiler is replacing an existing boiler with no other changes in the system, the old expansion tank can generally

be reused. If the expansion tank must be replaced, consult the expansion tank manufacturer’s literature for proper sizing.

- 5. Fill Valve (Required)** – Either manual (recommended) or automatic fill valve may be used. However, if automatic refill is employed, a water meter must be added to evaluate the makeup water volume taken after initial fill and eliminate any water leakage as early as possible.
- 6. Automatic Air Vent (Required)** – At least one automatic air vent is required. Manual vents will usually be required in other parts of the system to remove air during initial fill.
- 7. Manual Reset High Limit (Required by some Codes)** - This control is required by ASME CSD-1 and some other codes. Install the high limit in the boiler supply piping just above the boiler with no intervening valves. Set the manual reset high limit to 210°F. Follow Section VIII “Electrical” to wire the high limit.
- 8. Y-strainer (Recommended)** – A Y-strainer or equivalent strainer removes heating system debris from hydronic systems and protects boiler heat exchanger from fouling. Install the strainer downstream of full port isolation valve at the inlet side of the circulator for easy service.
- 9. Flow Control Valve (Strongly Recommended)** – The flow control valve prevents flow through the system unless the circulator is operating. Flow control valves are used to prevent gravity circulation or “ghost flows” in circulator zone systems through zones that are not calling for heat.

Table 14: Fitting and Valve Equivalent Length

Copper Fitting and Sweat Valve Equivalent Length (Ft)				
Fitting or Valve Description	Copper Pipe or Valve Size			
	1	1¼	1½	2
90° Elbow	2.5	3.0	4.0	5.5
45° Elbow	1.0	1.2	1.5	2.0
Tee (through flow)	0.5	0.6	0.8	1.0
Tee (Branch flow)	4.5	5.5	7.0	9.0
Diverter Tee (typical)	23.5	25.0	23.0	23.0
Gate Valve	0.3	0.4	0.5	0.7
Globe Valve	25.0	36.0	46.0	56.0
Angle Valve	5.3	7.8	9.4	12.5
Ball Valve (standard port)	4.3	7.0	6.6	14.0
Ball Valve (full port)	1.9	1.4	2.2	1.3
Swing Check Valve	4.5	5.5	6.5	9.0
Flow-Check Valve (typical)	54.0	74.0	57.0	177.0
Butterfly Valve	2.7	2.0	2.7	4.5

NOTE: Table 14 is provided as reference to assist in piping design and specifies equivalent length of typical piping fittings and valves.

Table 14: Fitting and Valve Equivalent Length (cont'd)

Threaded Fitting and Valve Equivalent Length (Ft)				
Fitting or Valve Description	Black Threaded Pipe or Valve Size			
	1	1¼	1½	2
90° Elbow	2.6	3.5	4.0	5.2
Long Radius Elbow (45° or 90°)	1.4	1.8	2.2	2.8
Tee (through flow)	1.8	2.3	2.7	3.5
Tee (Branch flow)	5.3	6.9	8.1	10.0
Close Return Bend	4.4	5.8	6.7	8.6
Gate Valve (full open)	0.7	0.9	1.1	1.4
Globe Valve (full open)	30.0	39.0	46.0	59.0
Angle Valve (full open)	13.0	17.0	20.0	26.0
Swing Check Valve (full open)	8.7	12.0	13.0	17.0
Flow-Check Valve (typical)	42.0	60.0	63.0	83.0

VI. Water Piping and Trim C. Standard Installation Requirements (continued)

10. Isolation Valves (Strongly Recommended) –

Isolation valves are useful when the boiler must be drained, as they will eliminate having to drain and refill the entire system.

11. Drain Valve (Required) – Drain valve is packaged loose with boiler and must be installed

in the location shown in Figure 19A, 19B or 19C “Factory Supplied Piping and Trim Installation”.

12. An optional LWCO with manual reset is available from Thermal Solutions to meet local code requirements.

NOTICE

The Apex boiler heat exchanger is made from stainless steel tubular coil having relatively narrow waterways. Once filled with water, it will be subject to the effects of corrosion. Failure to take the following precautions to minimize corrosion and heat exchanger waterways overheating could result in severe boiler damage.

- Before connecting the boiler, insure the system is free of impurities, grease, sediment, construction dust, sand, copper dust, flux and any residual boiler water additives. Flush the system thoroughly and repeatedly, if needed, with clear water mixed with concentrated rinse agent to remove these contaminants completely.
- Iron oxide (red oxide sludge Fe_2O_3) is produced during oxygenation. To minimize any oxygen presence in the system, the system must be air free and leak tight. Do not connect the boiler to radiant tubing without an oxygen barrier. Using automatic water refill is not recommended, however, if such refill is employed, a water meter must be added to evaluate the makeup water volume taken after initial fill and eliminate any water leakage as early as possible.
- Maintain the water pressure in the boiler at a minimum of 14.50 psi (100 kPa).
- The boiler water pH must be within $7.5 < \text{pH} < 9.5$. If the system contains any aluminum components, pH must be less than 8.5.
- Black oxide sludge (magnetite Fe_3O_4) forms as the result of continuous electrolytic corrosion in any system not protected by an inhibitor.
- Scale deposit is made up of lime scale contained in most distributed water and settles over the warmest surfaces of boiler heat exchanger causing subsequent overheating and eventual failure. Water hardness must be maintained within 3 to 9 grain/gal range.
- Refer to Section XI “Service and Maintenance” for recommended heating system water treatment products (corrosion/scale inhibitors, cleaners etc) and their suppliers.

VI. Water Piping and Trim C. Standard Installation Requirements (continued)

- A. No further apart than 12 inches (or four pipe diameters), whichever is smaller.
- B. Keep this distance as short as practical.
- C. At least 18" of straight pipe for Conventional Air Scoop.

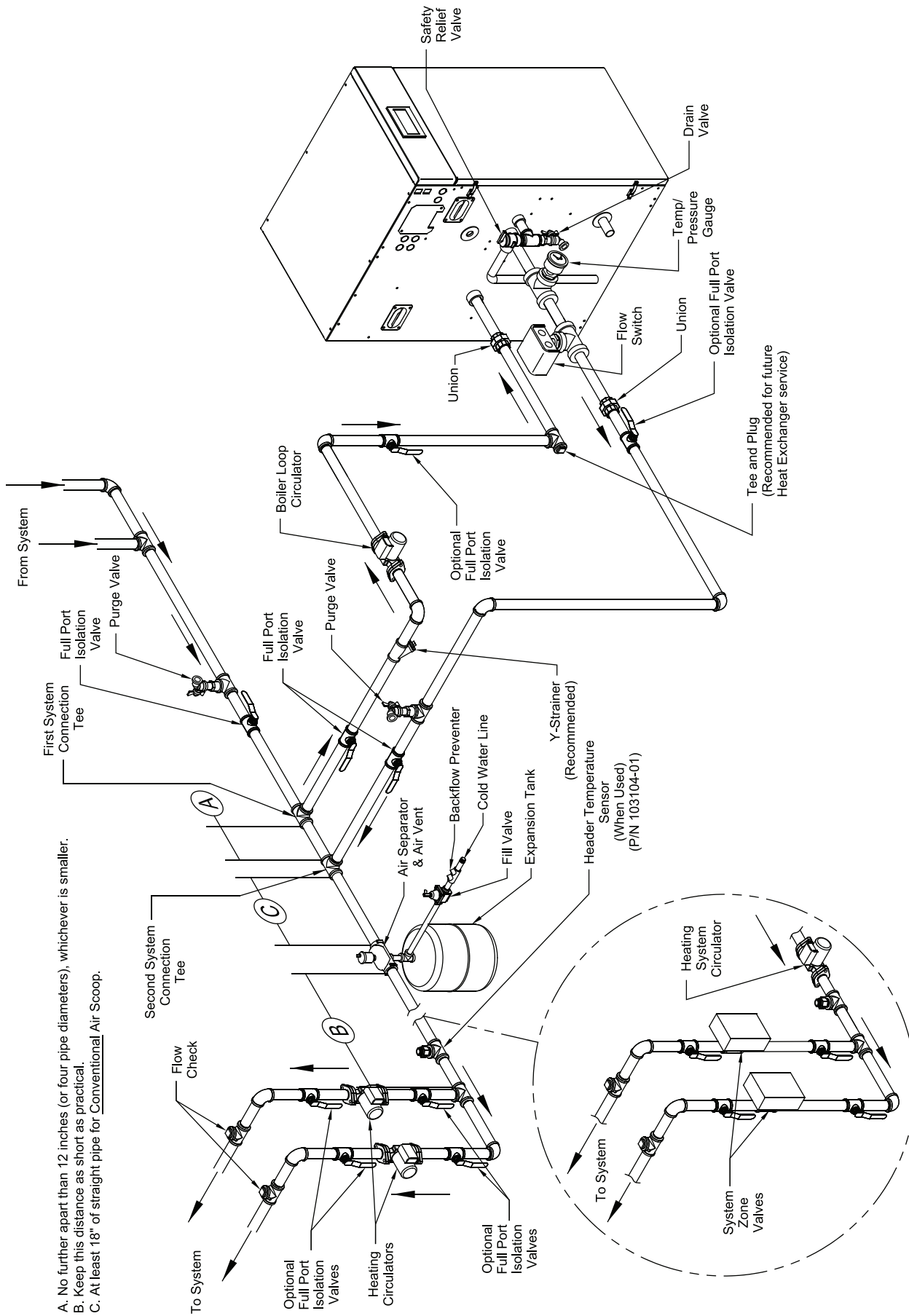
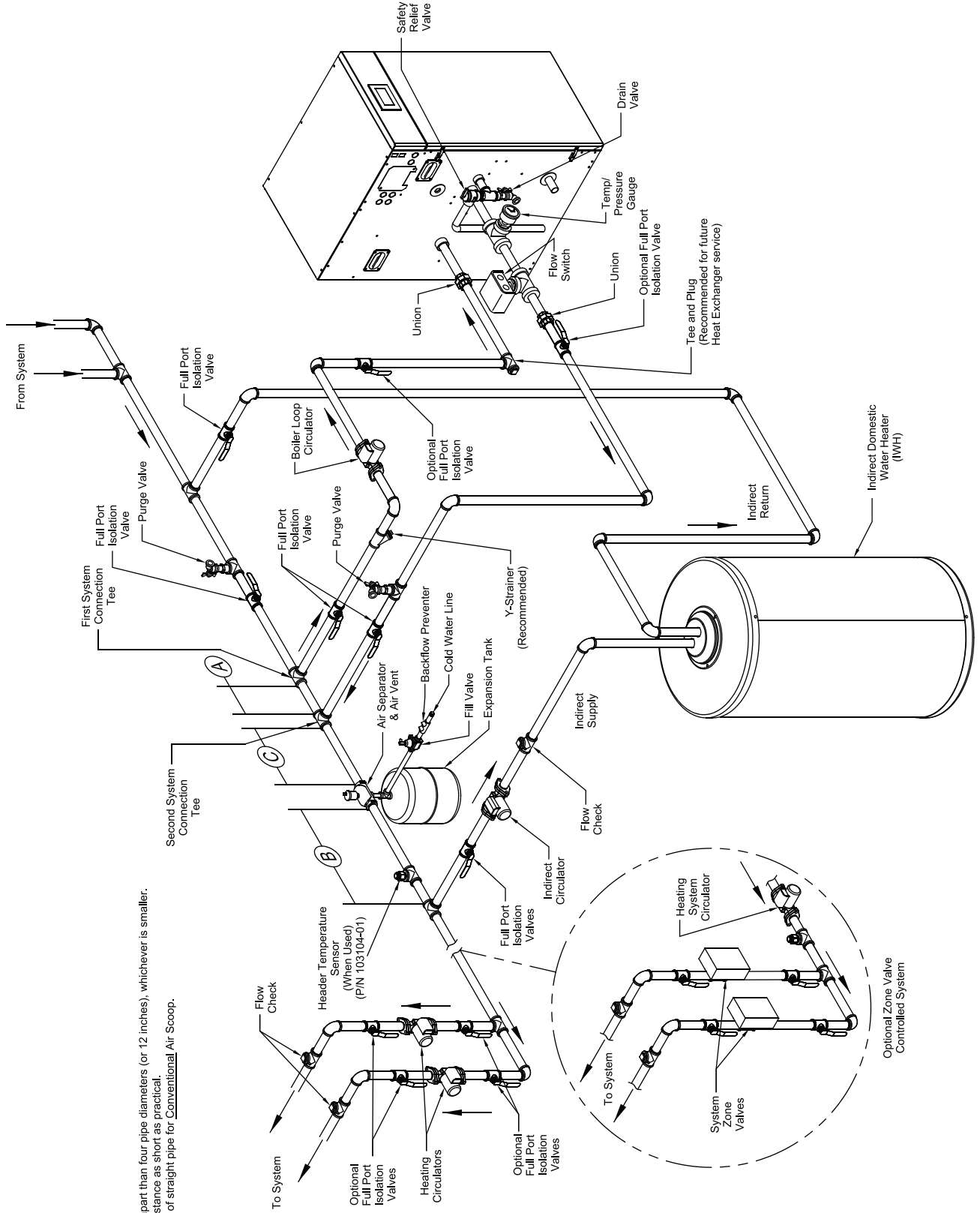

Figure 20: Near Boiler Piping - Heating Only

46 VI. Water Piping and Trim C. Standard Installation Requirements (continued)



- A. No further apart than four pipe diameters (or 12 inches), whichever is smaller.
- B. Keep this distance as short as practical.
- C. At least 18" of straight pipe for Conventional Air Scoop.

Figure 21: Near Boiler Piping - Heating Plus Indirect Water Heater

VI. Water Piping and Trim D. Special Situation Piping Installation Requirements (continued)

D. Special Situation Piping Installation Requirements

Observe the following guidelines when making the actual installation of the boiler piping for special situations:

1. Systems containing high level of dissolved oxygen – Many hydronic systems contain enough dissolved oxygen to cause severe corrosion damage to Apex boiler heat exchanger. Some examples include but not limited to:

- Radiant systems employing tubing without oxygen barrier
- Systems with routine additions of fresh water
- Systems open to atmosphere

If the boiler is used in such a system, it must be separated from oxygenated water being heated with a heat exchanger as shown in Figures 22A and 22B. Consult the heat exchanger manufacturer for proper heat exchanger sizing as well as flow and temperature requirements. All components on the oxygenated side of the heat exchanger, such as the pump and expansion tank, must be designed for use in oxygenated water.

2. Piping with a Chiller - If the boiler is used in conjunction with a chiller, pipe the boiler and chiller in parallel. Use isolation valves to prevent chilled water from entering the boiler.

3. Boiler Piping with Air Handlers - Where the boiler is connected to air handlers through which refrigerated air passes, use flow control valves in the boiler piping or other automatic means to prevent gravity circulation during the cooling cycle.

Table 15: Multiple Boiler Water Manifold Sizing

Boiler Model	Number of Units						
	2	3	4	5	6	7	8
	Recommended Minimum Common Water Manifold Size (NPT)						
APX425	2½"	3"	3"	4"	5"	5"	5"
APX525	3"	4"	4"	5"	5"	6"	6"
APX625	3"	4"	5"	5"	6"	6"	6"
APX725	4"	4"	5"	6"	6"	8"	8"
APX825	4"	5"	5"	6"	6"	8"	8"

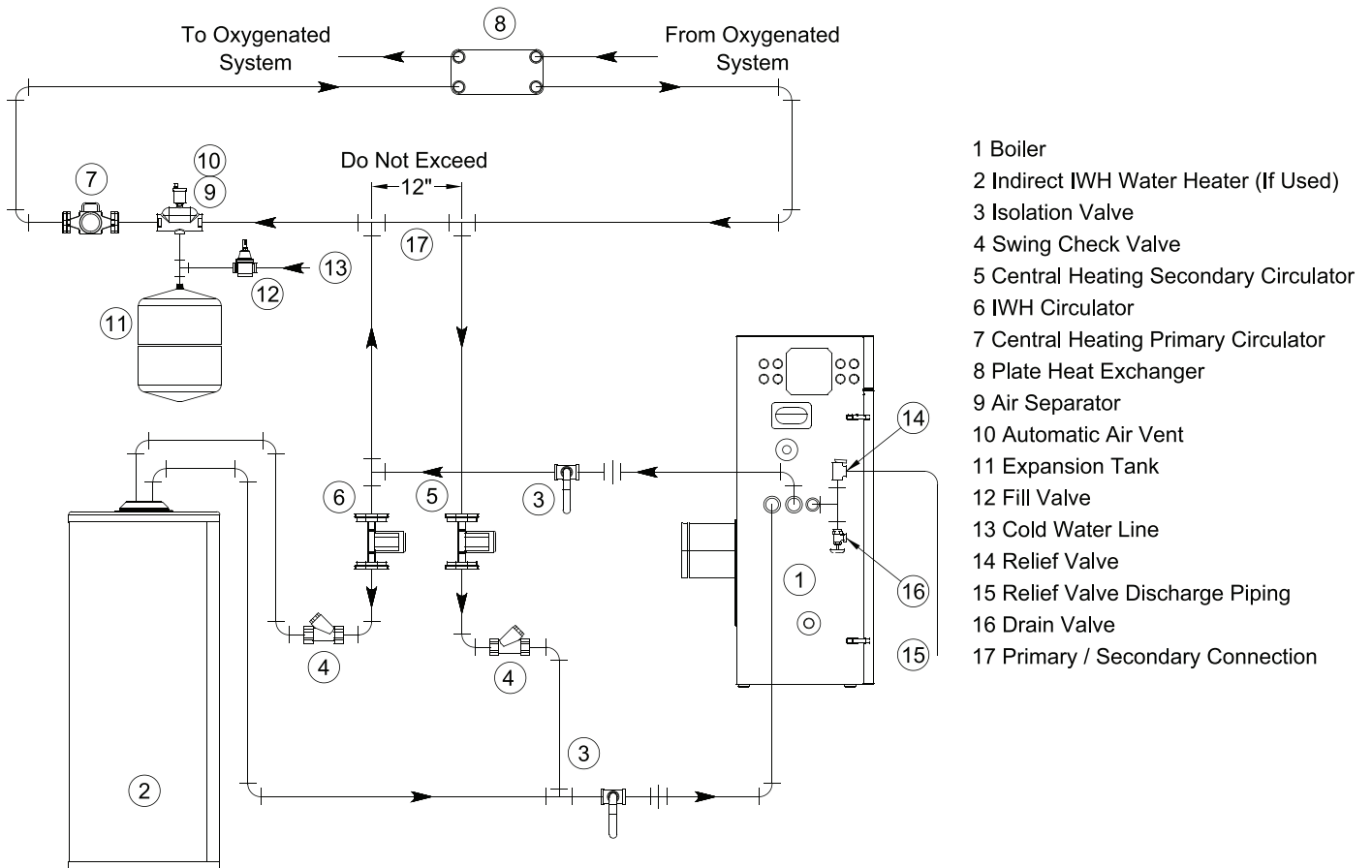

Figure 22A: Isolation of the Boiler From Oxygenated Water with A Plate Heat Exchanger (IWH Piped as Part of Boiler Piping)

VI. Water Piping and Trim E. Multiple Boiler Installation Water Piping (continued)

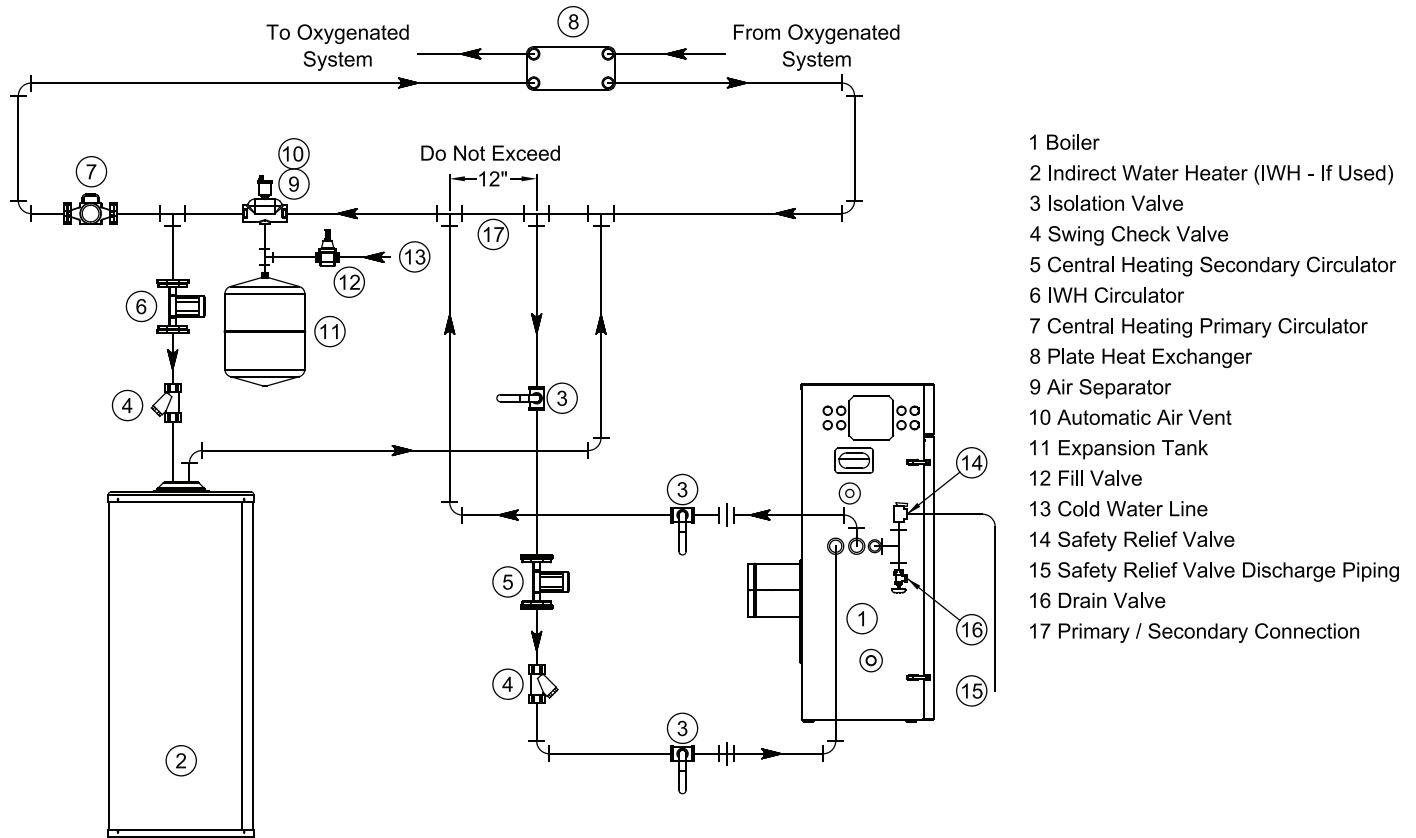

Figure 22B: Isolation of the Boiler From Oxygenated Water with A Plate Heat Exchanger (IWH Piped Off System Header)

E. Multiple Boiler Installation Water Piping - See Table 15 and Figures 22B 23A and 23B.

1. Refer to this Section of this manual for:

- Installation of factory supplied piping and trim components for an individual module (boiler).
- Regarding an individual module (boiler) piping system specific details.
- Selection criteria for individual module (boiler) space heating and/or DHW circulators.

- For installations where indirect domestic hot water heater is combined with space heating, the Alliance SL™ model must be piped as a separate heating zone off the system header. The circulator must be sized based on the Alliance SL™ model coil flow and combined coil pressure drop and the zone piping total equivalent length. Refer to Alliance SL™ Indirect Water Heater literature for specific model coil flow and pressure drop. Refer to Figures 23A and 23B.

VI. Water Piping and Trim E. Multiple Boiler Installation Water Piping (continued)

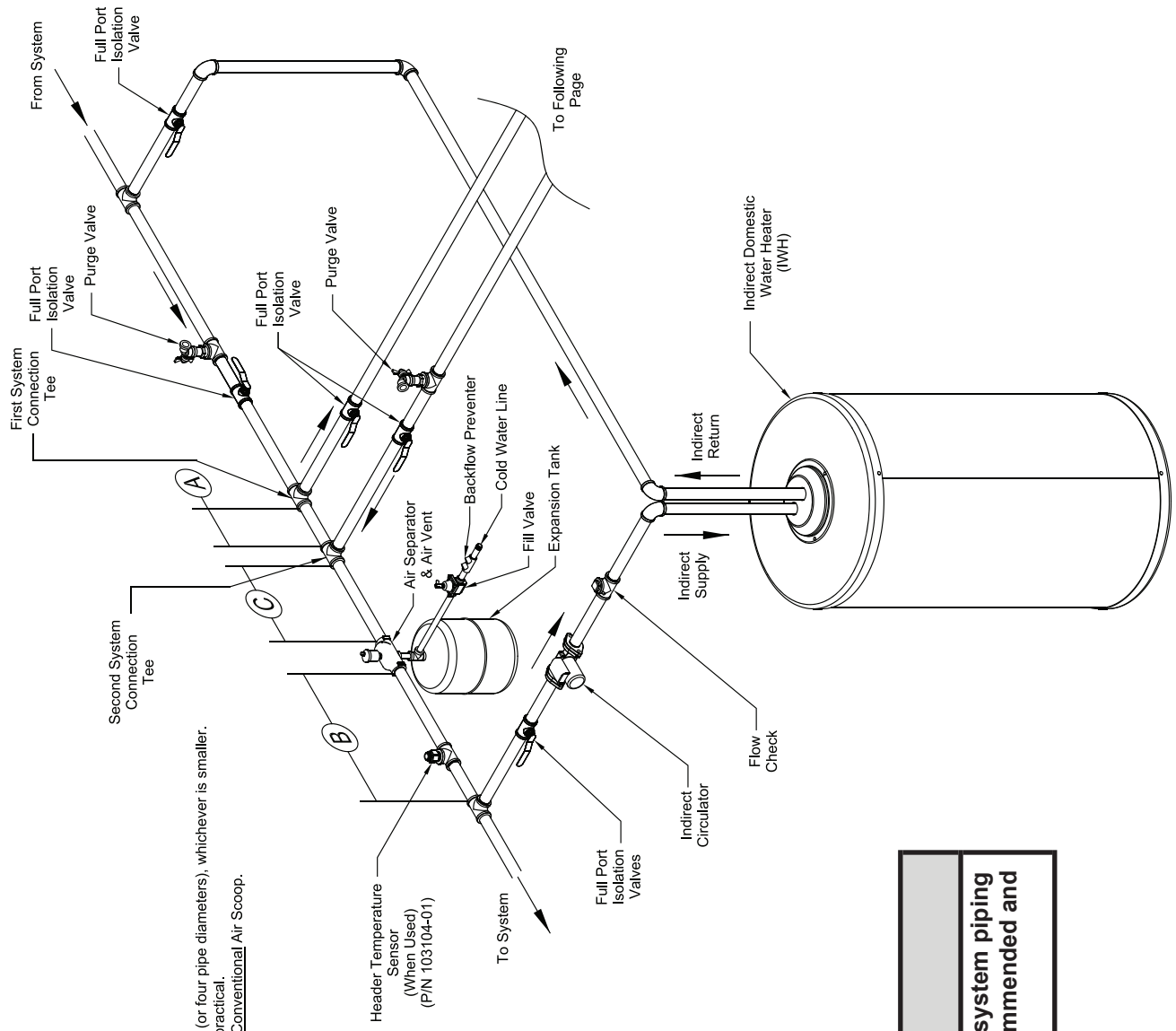

- A. No further apart than 12 inches (or four pipe diameters), whichever is smaller.
- B. Keep this distance as short as practical.
- C. At least 18" of straight pipe for Conventional Air Scoop.

NOTICE

Installing a low water cutoff in the system piping of multiple boilers is strongly recommended and may be required by local codes.

Figure 23A: Multiple Boiler Water Piping w/Domestic Hot Water Heater (Page 1 of 2)

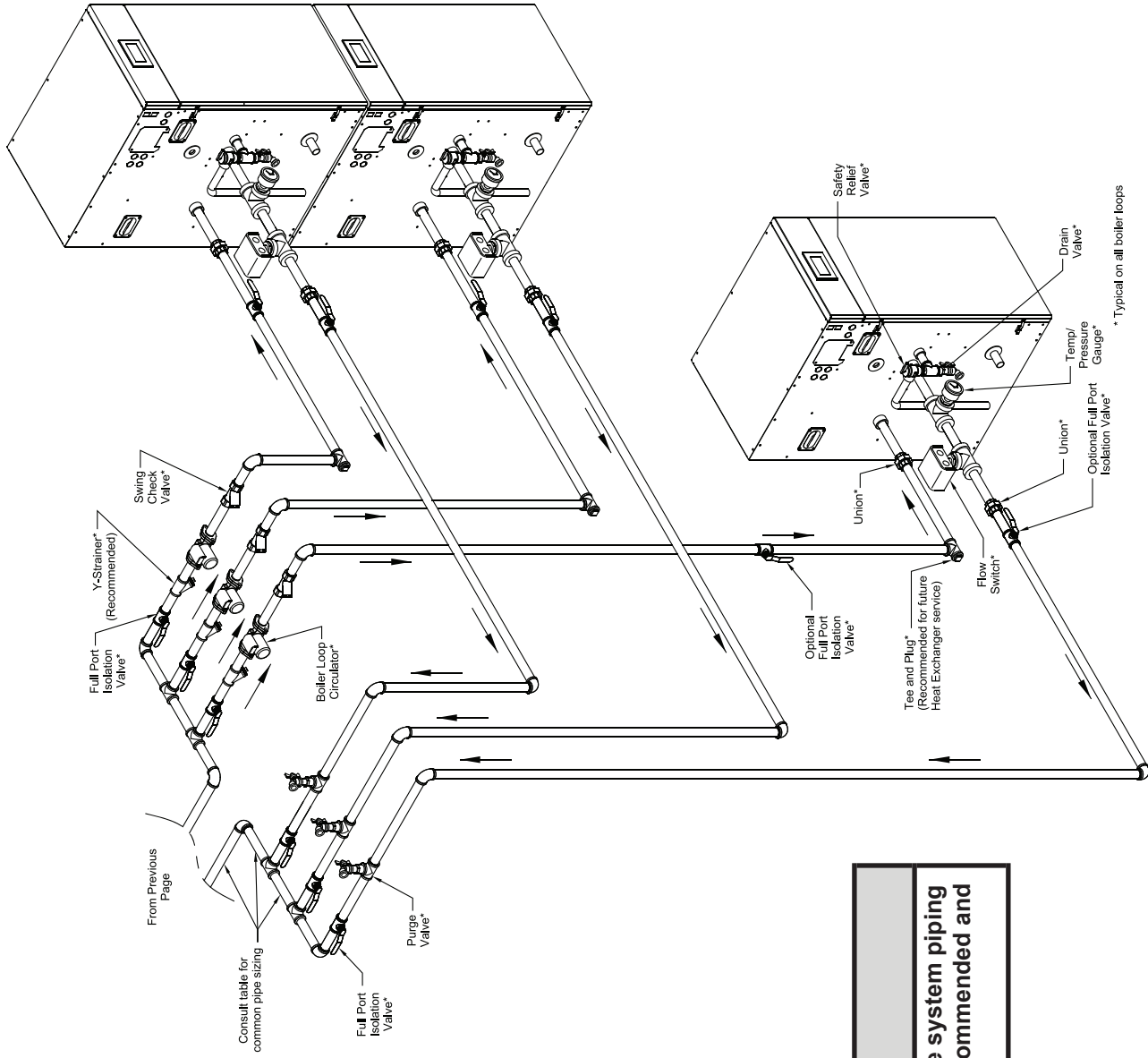

NOTICE
 Installing a low water cutoff in the system piping of multiple boilers is strongly recommended and may be required by local codes.

Figure 23B: Multiple Boiler Water Piping w/Domestic Hot Water Heater (Page 2 of 2)

VII. Gas Piping



WARNING

Explosion Hazard. Failure to properly pipe gas supply to boiler may result in improper operation and damage to the boiler or structure. Always assure gas piping is absolutely leak free and of the proper size and type for the connected load. An additional gas pressure regulator may be needed. Consult gas supplier.

NOTICE

Size corrugated stainless steel tubing (CSST) to ensure proper capacity and minimize flow restrictions.

A. Size gas piping. Design system to provide adequate gas supply to boiler. Consider these factors:

- 1. Allowable pressure drop from point of delivery to boiler.** Maximum allowable system pressure is ½ psig (3.4 kPa). Actual point of delivery pressure may be less; contact gas supplier for additional information. Minimum gas valve inlet pressure is printed on the rating label located in the boiler's vestibule compartment.
- 2. Maximum gas demand.** Refer to the boiler's input as printed on its rating label. Also consider existing and expected future gas utilization equipment (i.e. water heater, cooking equipment).
- 3. Length of piping and number of fittings.** Refer to Tables 16A (natural gas) or 16B (LP gas) for maximum capacity of Schedule 40 pipe. Table 17 lists equivalent pipe length for standard fittings.
- 4. Specific gravity of gas.** Gas piping systems for gas with a specific gravity of 0.60 can be sized directly from Table 16A and gas with a specific gravity of 1.5 can be sized from Table 16B, unless authority having jurisdiction specifies a gravity factor be applied. For other specific gravity, apply gravity factor from Table 18. If exact specific gravity is not shown choose next higher value.

Table 16A: Maximum Capacity of Schedule 40 Black Pipe in CFH* (Natural Gas) For Gas Pressures of 1/2 psi (3.4 kPa) or Less

Inlet Pressure 13.8 in wc (3.4 kPa) or less; 0.3 in wc (0.07 kPa) Pressure Drop											
Nominal Pipe Size, In.	Inside Diameter, In.	Length of Pipe, Ft.									
		10	20	30	40	50	60	70	80	90	100
½	0.622	131	90	72	62	55	50	46	42	40	38
¾	0.824	273	188	151	129	114	104	95	89	83	79
1	1.049	514	353	284	243	215	195	179	167	157	148
1¼	1.380	1056	726	583	499	442	400	368	343	322	304
1½	1.610	1582	1087	873	747	662	600	552	514	482	455
2	2.067	3046	2094	1681	1439	1275	1156	1063	989	928	877
2½	2.469	4856	3337	2680	2294	2033	1842	1695	1576	1479	1397
3	3.068	8584	5900	4738	4055	3594	3256	2996	2787	2615	2470

Inlet Pressure 13.8 in wc (3.4 kPa) or less; 0.5 in wc (0.12 kPa) Pressure Drop											
Nominal Pipe Size, In.	Inside Diameter, In.	Length of Pipe, Ft.									
		10	20	30	40	50	60	70	80	90	100
½	0.622	172	118	95	81	72	65	60	56	52	50
¾	0.824	360	247	199	170	151	137	126	117	110	104
1	1.049	678	466	374	320	284	257	237	220	207	195
1¼	1.380	1392	957	768	657	583	528	486	452	424	400
1½	1.610	2085	1433	1151	985	873	791	728	677	635	600
2	2.067	4016	2760	2217	1897	1681	1523	1402	1304	1223	1156
2½	2.469	6401	4400	3533	3024	2680	2428	2234	2078	1950	1842
3	3.068	11316	7778	6246	5345	4738	4293	3949	3674	3447	3256

* 1 CFH of Natural Gas is approximately equal to 1 MBH; contact your gas supplier for the actual heating value of your gas.

VII. Gas Piping (continued)

For materials or conditions other than those listed above, refer to *National Fuel Gas Code*, ANSI Z223.1/ NFPA 54 or *Natural Gas and Propane Installation Code*, CAN/CSA B149.1, or size system using standard engineering methods acceptable to authority having jurisdiction.

B. Connect boiler gas valve to gas supply system.

Table 16B: Maximum Capacity of Schedule 40 Black Pipe in CFH* (LP Gas) For Gas Pressures of 1/2 psi (3.4 kPa) or Less

Inlet Pressure 11.0 in wc (2.7 kPa); 0.3 in wc (0.07 kPa) Pressure Drop											
Nominal Pipe Size, In.	Inside Diameter, In.	Length of Pipe, Ft.									
		10	20	30	40	50	60	70	80	90	100
½	0.622	88	60	48	41	37	33	31	29	27	25
¾	0.824	184	126	101	87	77	70	64	60	56	53
1	1.049	346	238	191	163	145	131	121	112	105	100
1¼	1.380	710	488	392	336	297	269	248	231	216	204
1½	1.610	1064	732	588	503	446	404	371	346	324	306
2	2.067	2050	1409	1131	968	858	778	715	666	624	590
2½	2.469	3267	2246	1803	1543	1368	1239	1140	1061	995	940
3	3.068	5776	3970	3188	2729	2418	2191	2016	1875	1760	1662

Inlet Pressure 11.0 in wc (2.7 kPa); 0.5 in wc (0.12 kPa) Pressure Drop											
Nominal Pipe Size, In.	Inside Diameter, In.	Length of Pipe, Ft.									
		10	20	30	40	50	60	70	80	90	100
½	0.622	116	80	64	55	48	44	40	38	35	33
¾	0.824	242	166	134	114	101	92	85	79	74	70
1	1.049	456	314	252	215	191	173	159	148	139	131
1¼	1.380	937	644	517	442	392	355	327	304	285	269
1½	1.610	1403	964	775	663	588	532	490	456	427	404
2	2.067	2703	1858	1492	1277	1131	1025	943	877	823	778
2½	2.469	4308	2961	2377	2035	1803	1634	1503	1399	1312	1239
3	3.068	7615	5234	4203	3597	3188	2889	2658	2472	2320	2191

* 1 CFH of LP Gas is approximately equal to 2.5 MBH; contact your gas supplier for the actual heating value of your gas.

Table 17: Equivalent Lengths of Standard Pipe Fittings & Valves (ft)

Nominal Pipe Size, Inc.	Inside Diameter, In.	Valves (Screwed) - Fully Open				Screwed Fittings				
		Gate	Globe	Angle	Swing Check	45° Elbow	90° Elbow	180 Close Return Bend	90 Tee Flow Through Run	90 Tee, Flow Through Branch
½	0.622	0.4	17.3	8.7	4.3	0.7	1.6	3.5	1.6	3.1
¾	0.824	0.5	22.9	11.4	5.7	1.0	2.1	4.6	2.1	4.1
1	1.049	0.6	29.1	14.6	7.3	1.2	2.6	5.8	2.6	5.2
1¼	1.38	0.8	38.3	19.1	9.6	1.6	3.5	7.7	3.5	6.9
1½	1.61	0.9	44.7	22.4	11.2	1.9	4.0	9.0	4.0	8.0
2	2.067	1.2	57.4	28.7	14.4	2.4	5.2	11.5	5.2	10.3
2½	2.469	1.4	68.5	34.3	17.1	2.9	6.2	13.7	6.2	12.3
3	3.068	1.8	85.2	42.6	21.3	3.6	7.7	17.1	7.7	15.3

VII. Gas Piping (continued)

Table 18: Specific Gravity Correction Factors

Specific Gravity	Correction Factor	Specific Gravity	Correction Factor
0.60	1.00	0.90	0.82
0.65	0.96	1.00	0.78
0.70	0.93	1.10	0.74
0.75	0.90	1.20	0.71
0.80	0.87	1.30	0.68
0.85	0.81	1.40	0.66



WARNING

Explosion Hazard. Failure to use proper thread compounds on all gas connectors may result in leaks of flammable gas.

Gas supply to boiler and system must be absolutely shut off prior to installing or servicing boiler gas piping.

- 1. Use methods and materials in accordance** with local plumbing codes and requirements of gas supplier. In absence of such requirements, follow *National Fuel Gas Code*, ANSI Z223.1/NFPA 54 and/or *Natural Gas and Propane Installation Code*, CAN/CSA B149.1.
- 2. Use thread (joint) compounds (pipe dope)** resistant to action of liquefied petroleum gas.
- 3. Apex boilers have factory supplied** miscellaneous parts cartons, which include gas-piping components to connect boiler gas valve(s) to gas supply system. Install these components prior to connecting boiler to gas supply system piping as follows:

Boiler Model	Miscellaneous Parts Carton
APX425	102942-05
APX525	
APX625	104520-01
APX725	
APX825	103259-02

Models APX425 and APX525

- Locate and remove the 3/4 in. NPT x 6 in. long black nipple and 3/4 in. NPT external gas shutoff valve (required).
- Model APX525 boiler has 3/4 in. NPT x 12 in. long black nipple and left side panel grommet factory installed (disregard the supplied 3/4 in. NPT x 6 in. long black nipple in the miscellaneous parts carton).
- Mount the 3/4 in. NPT external gas shutoff valve onto the nipple threaded end outside of the jacket left side panel.

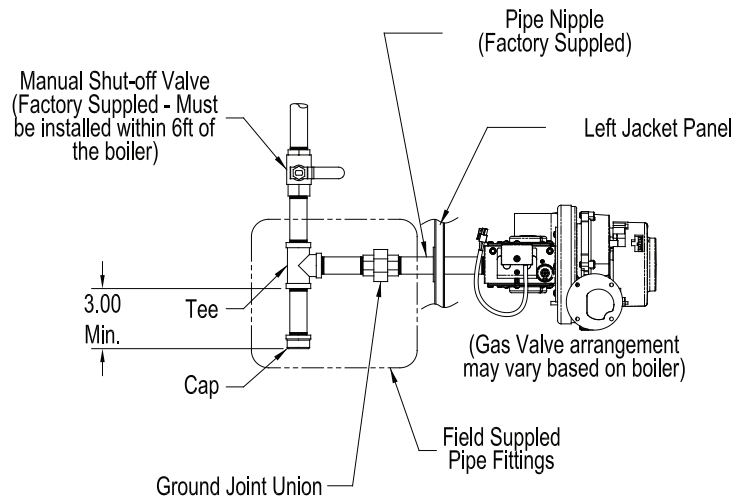

Figure 24: Recommended Gas Piping

- Install sediment trap, ground-joint union and manual shut-off valve upstream of mounted factory supplied manual shut-off valve. See Figure 24 “Recommended Gas Piping”.

Models APX625, APX725 and APX825

- Locate and remove 1 in. NPT external gas shutoff valve (required).
- Models APX625, APX725 and APX825 have 1 in. NPT black nipple and left side panel grommet factory installed.
- Mount the 1 in. NPT external gas shutoff valve onto the nipple threaded end outside of the jacket left side panel.
- Install sediment trap, ground-joint union and manual shut-off valve upstream of mounted factory supplied manual shut-off valve. See Figure 24 “Recommended Gas Piping”.

Table 19: Min./Max. Pressure Ratings

Boiler Model No.	Natural/LP Gas Max. Pressure (in. w.c.)	Natural Gas Min. Pressure Inlet to Gas Valve (in. w.c.)	LP Gas Min. Pressure Inlet to Gas Valve (in. w.c.)
APX425	13.5	4.0	11.0
APX525	13.5	4.5	
APX625			
APX725			
APX825			

- 4. All above ground gas piping** upstream from manual shut-off valve must be electrically continuous and bonded to a grounding electrode. Do not use gas piping as grounding electrode. Refer to *National Electrical Code*, NFPA 70 and/or *Canadian Electrical Code Part 1*, CSA C22.1, Electrical Code.

VII. Gas Piping (continued)

C. Pressure test. See Table 19 for Apex Min./Max. Pressure Ratings. The boiler and its gas connection must be leak tested before placing boiler in operation.

- 1. Protect boiler gas control valve.** For all testing over ½ psig (3.4 kPa), boiler and its individual shutoff valve must be disconnected from gas supply piping. For testing at ½ psig (3.4 kPa) or less, isolate boiler from gas supply piping by closing boiler's individual manual shutoff valve.
- 2. Locate leaks** using approved combustible gas non-corrosive leak detector solution.

DANGER

Explosion Hazard. Do not use matches, candles, open flames or other ignition source to check for leaks.

D. Apex Models APX525, APX625, APX725 and APX825 (if equipped with optional low and high gas pressure switches):

- 1. Verify low and high gas pressure switch settings** are within the range shown in Table 19. The switches are preset for natural gas. For LP gas, the low gas pressure switch setting must be adjusted.
- 2. The low gas pressure switch** must be reset after the boiler is piped to the gas supply and before it is fired.

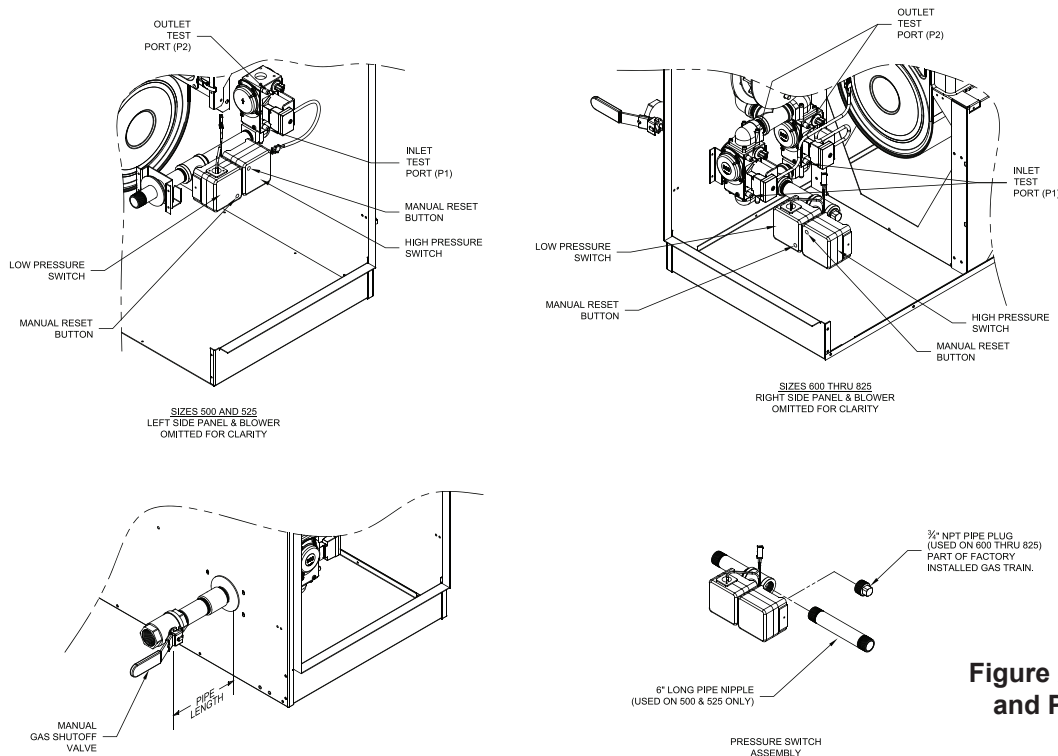



Figure 25: Gas Inlet Pressure Tap and Pressure Switch Location

- 3. For the low and high gas pressure switches** proper operation, the boiler inlet gas pressure must be within the range shown in Table 19.
- 3. The gas pressure can be measured** at the gas valve inlet pressure port. Refer to Figure 25 “Gas Inlet Pressure Tap and Pressure Switch Location”.
- 4. If either pressure switch is tripped,** it must be manually reset before the boiler can be restarted.

E. Gas Piping for Multiple Boiler Installation

- 1. Individual module (boiler) gas pipe sizing specific details** - see Paragraph A.
- 2. Individual module (boiler) recommended gas piping detail** - see Figure 24.
- 3. An additional gas pressure regulator(s)** may need to be installed to properly regulate inlet gas pressure at the smallest individual module (boiler).

CAUTION

If gas pressure in the building is above ½ psig (3.4 kPa), an additional gas pressure regulator is required. Using one additional regulator for multiple boilers may result in unsafe boiler operation. The additional regulator must be able to properly regulate gas pressure at the input of the smallest boiler. If the regulator cannot do this, two or more additional regulators are required. Consult regulator manufacturer and/or local gas supplier for instructions and equipment ratings.

VIII. Electrical



DANGER

Electrical Shock Hazard. Positively assure all electrical connections are unpowered before attempting installation or service of electrical components or connections of the boiler or building. Lock out all electrical boxes with padlock once power is turned off.



WARNING

Electrical Shock Hazard. Failure to properly wire electrical connections to the boiler may result in serious physical harm.

Electrical power may be from more than one source. Make sure all power is off before attempting any electrical work.

Each boiler must be protected with a properly sized over-current device.

Never jump out or make inoperative any safety or operating controls.

The wiring diagrams contained in this manual are for reference purposes only. Each boiler is shipped with a wiring diagram attached to the front door. Refer to this diagram and the wiring diagram of any controls used with the boiler. Read, understand and follow all wiring instructions supplied with the controls.

NOTICE

This boiler is equipped with a high water temperature limit located inside the internal wiring of the boiler. This limit provides boiler shutdown in the event the boiler water temperature exceeds the set point of the limit control. Certain local codes require an additional water temperature limit. In addition, certain types of systems may operate at temperatures below the minimum set point of the limit contained in the boiler.

If this occurs, install an additional water temperature limit (Honeywell L4006 Aquastat). Wire as indicated in the Electrical Section of this manual.

All wire, wire nuts, controls etc. are installer supplied unless otherwise noted.

A. General. Install wiring and electrically ground boiler in accordance with authority having jurisdiction or, in the absence of such requirements, follow the *National Electrical Code*, NFPA 70, and/or *Canadian Electrical Code* Part 1, CSA C22.1 Electrical Code.

B. A separate electrical circuit must be run from the main electrical service with an over-current device/disconnect in the circuit. A service switch is recommended and may be required by some local jurisdictions. Install the service switch in the line voltage “Hot” leg of the power supply. Locate the service switch such that the boiler can be shut-off without exposing personnel to danger in the event of an emergency. Connect the main power supply and ground to the 3 boiler wires (black, white and green) located in the junction box at top left side of the boiler jacket.

C. Refer to Figures 26 and 27 for details on the internal boiler wiring.

Line Voltage (120 VAC) Connections - see Figure 27.

1. The line voltage connections are located in the junction box on the left side of the vestibule. The terminal block TB-1 in conjunction with terminal screw identification label is attached to the junction box combination cover/inside high voltage bracket.

2. The conductor insulation colors are:

- a. Black – L1 line voltage “Hot”
- b. White – L2 line voltage “Neutral” for boiler and circulators
- c. Red – Line voltage “Hot” for “Heating” circulator, “System” circulator and “DHW” circulator
- d. Green – Ground connection

Low Voltage (24 VAC) Connections - see Figure 27.

VIII. Electrical (continued)

3. The terminal block TB-2 in conjunction with terminal screw identification label is attached to the junction box front and located inside R7910 Control compartment on the left side.

4. The connections are (listed identification label top to bottom):

- 1 – “Heating Thermostat”
- 2 – “Heating Thermostat”
- 3 – “DHW Temperature Switch”
- 4 – “DHW Temperature Switch”
- 5 – “Outdoor Sensor”
- 6 – “Outdoor Sensor”
- 7 – “Header Sensor”
- 8 – “Header Sensor”
- 9 – “Remote Firing Rate -”
- 10 – “Remote Firing Rate +”
- 11 – “External Limit”
- 12 – “External Limit”

5. If the outdoor sensor is connected to terminals 5 and 6 “Outdoor Sensor”, the boiler will adjust the target space heating set point supply water temperature downwards as the outdoor air temperature increases. If used, this sensor should be located on the outside of the structure in an area where it will sense the average air temperature around the house. Avoid placing this sensor in areas where it may be covered with ice or snow. Locations where the sensor will pick up direct radiation from the sun should also be avoided. Avoid placing the sensor near potential sources of electrical noise such as transformers, power lines, and fluorescent lighting. Wire the sensor to the boiler using 22 gauge or larger wire. As with the sensor, the sensor wiring should be routed away from sources of electrical noise. Where it is impossible to avoid such noise sources, wire the sensor using a 2 conductor, UL Type CM, AWM Style 2092, 300 Volt 60°C shielded cable. Connect one end of the shielding on this cable to ground.

NOTICE

When making low voltage connections, make sure that no external power source is present in the thermostat or limit circuits. If such a power source is present, it could destroy the boiler’s microprocessor control (R7910). One example of an external power source that could be inadvertently connected to the low voltage connections is a transformer in old thermostat wiring.

D. Power Requirements

Nominal boiler current draw is provided in Table 20. These values are for planning purposes only and represent only the boiler’s power consumption. To obtain total system power consumption add any selected circulator and component current draws.

Table 20: Boiler Current Draw

Model Number	Nominal Current (amps)
APX425	< 7
APX525	< 6
APX625	< 8
APX725	< 8
APX825	< 8

E. Flow Switch Wiring

Apex boilers include factory provided flow switch to prevent boiler overheating. See Section VI, Water Piping and Trim for pertinent details.

The flow switch is an operating control and must be used in combination and wired in series with boiler safety high limit control and other safety controls where applicable.

Wiring of the switch to boiler, including wire and conduit supplies, is the responsibility of the installing contractor. Use properly rated temperature wire for the anticipated service temperature. Make all electrical connections in accordance with the *National Electrical Code*, NFPA 70, and/or *Canadian Electrical Code* Part 1, CSA C22.1 and local codes, where applicable.

To wire the installed flow switch proceed as follows:

1. **Remove jumper** that is factory installed between terminals 11 and 12 at the low voltage terminal strip located inside boiler control panel assembly.
2. **Using installer-provided wire and conduit**, wire the switch NO (normally open) terminal to the terminal 11 and, the switch COM (common) terminal to terminal 12. Also see/follow Taco Instruction Sheet for Flow Switch Kit supplied with the flow switch for specific details and Figure 26 “Ladder Diagram” and Figure 27 “Connection Diagram” in this section.

F. Multiple Boiler Wiring

Install over-current protection in accordance with authority having jurisdiction or, in the absence of such requirements, follow the *National Electric Code*, NFPA 70, and/or *Canadian Electrical Code* Part 1, CSA C22.1. Do not provide over-current protection greater than 15 amperes. If it becomes necessary to provide greater amperes (because of the number of boilers provided) use separate circuits and over-current protection for additional boilers.

VIII. Electrical (continued)

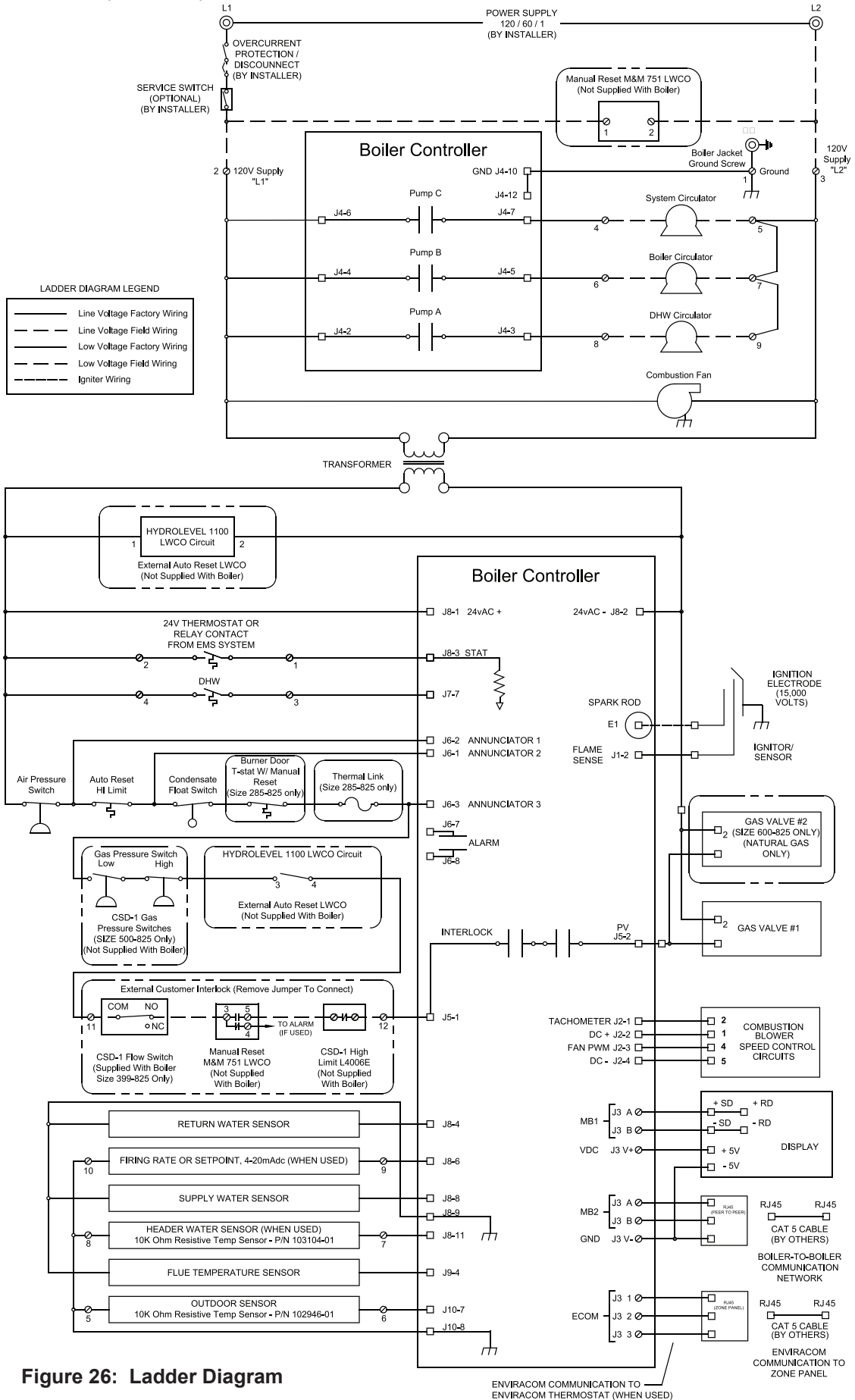
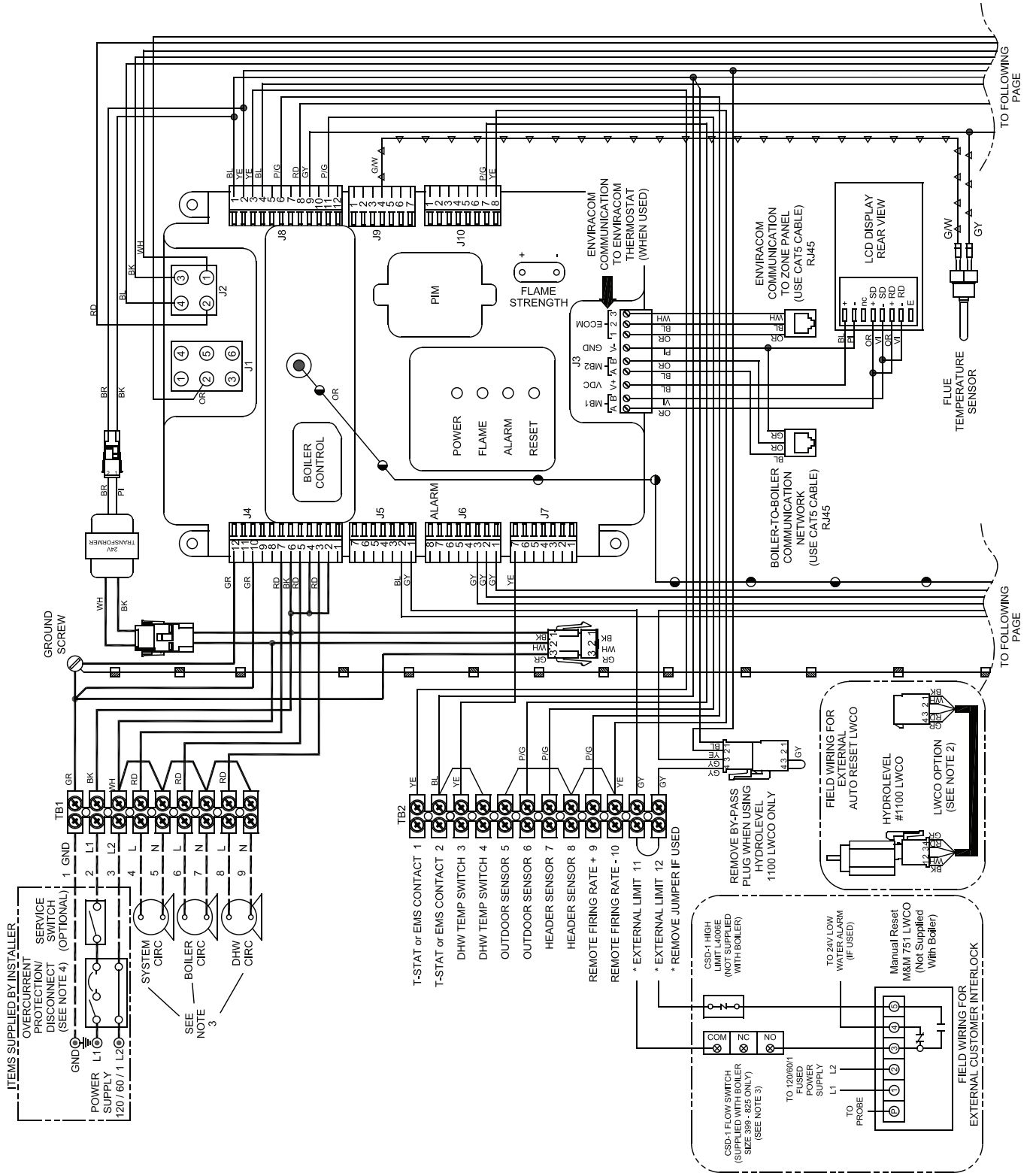

Figure 26: Ladder Diagram



TO FOLLOWING PAGE

TO FOLLOWING PAGE

VIII. Electrical (continued)

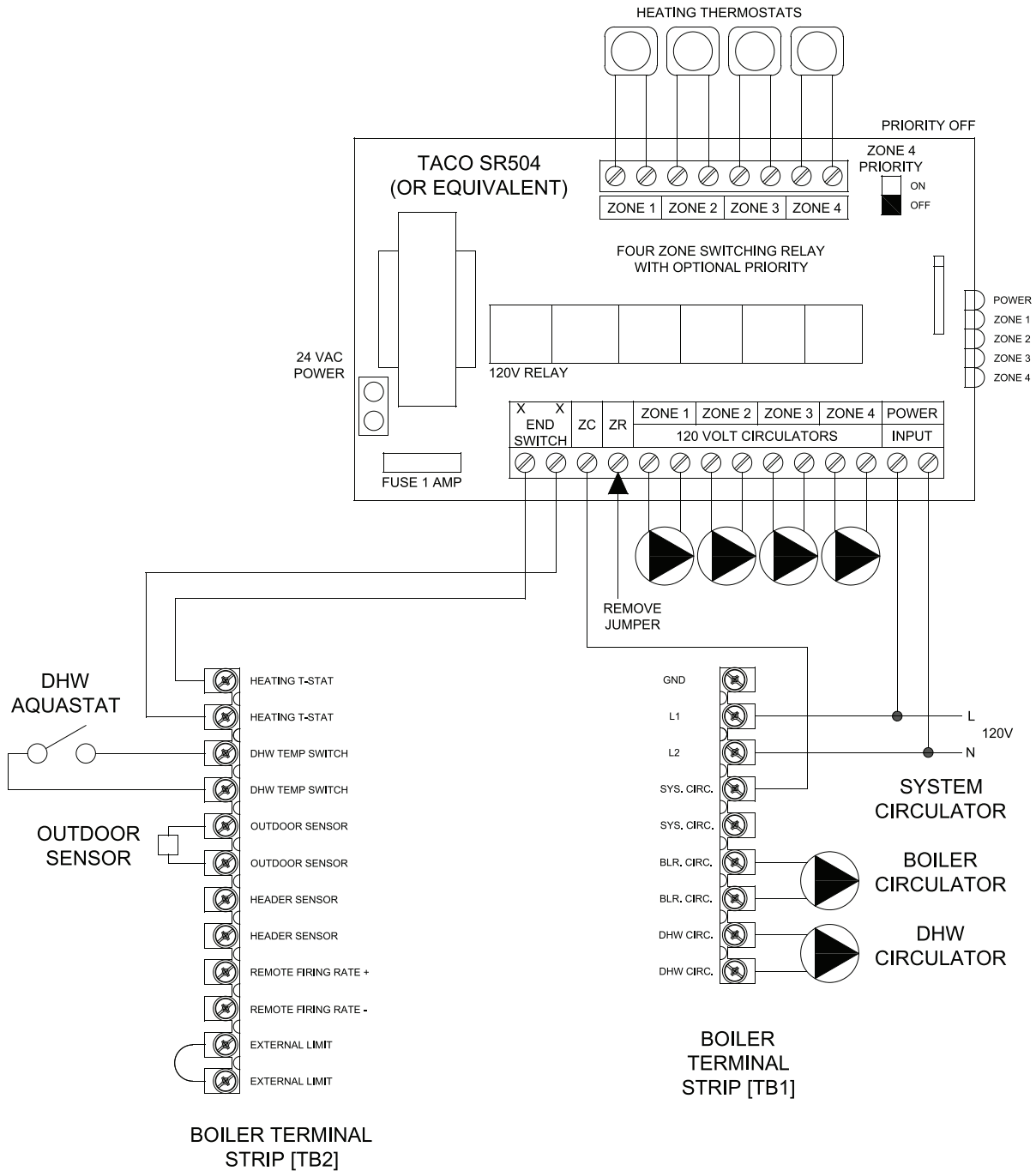

***USE SAME POWER SOURCE FOR ALL CONTROLS AND ENSURE POLARITY TO ALL CONTROL DEVICES IS CORRECT

Figure 28A: Modified Wiring For DHW Priority When Using Low Flow Circulator Piped Off System Header - Heating (with Central Heating Circulators) Plus Alternately Piped Indirect Water Heater

VIII. Electrical (continued)

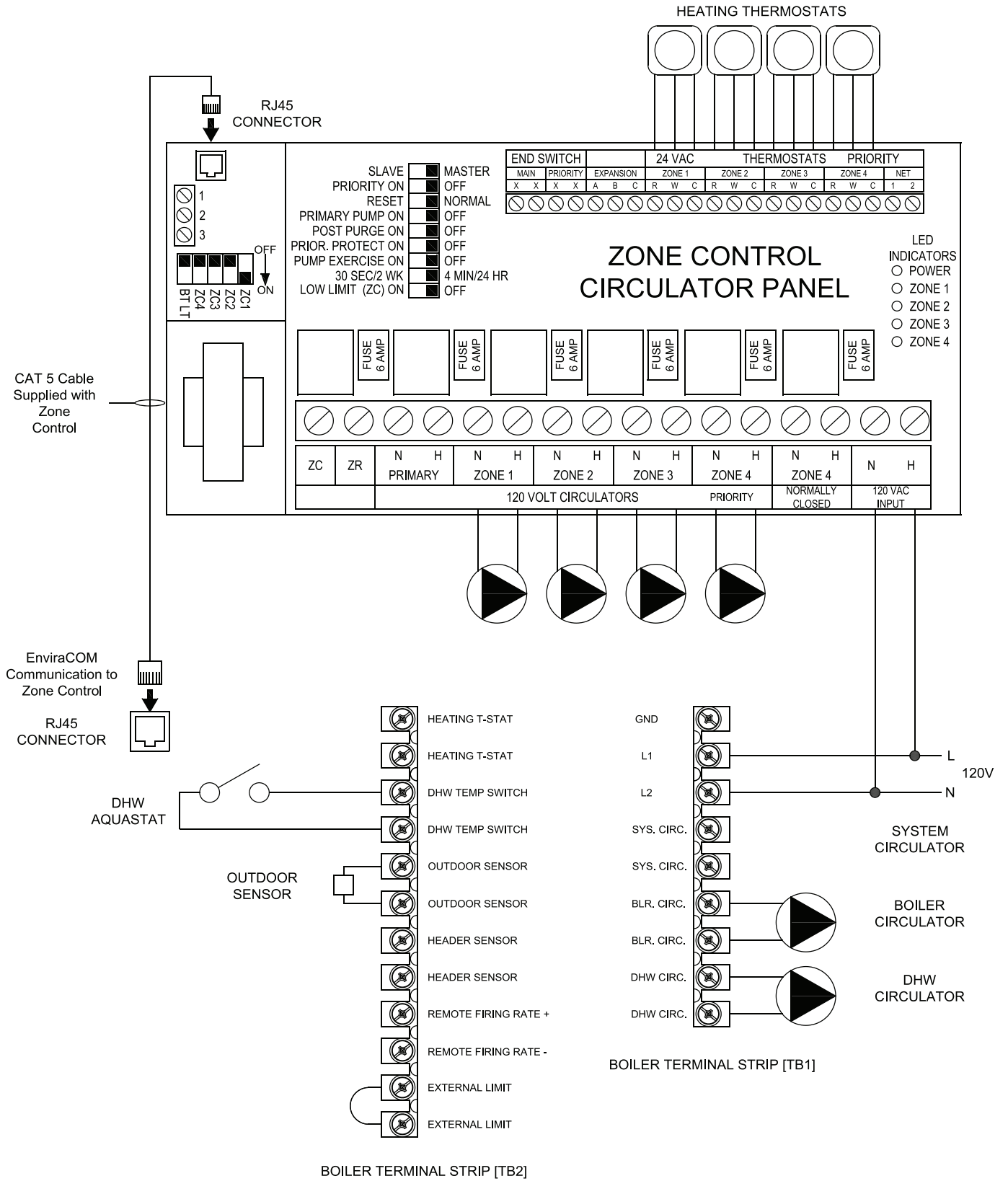

Figure 28B: DHW Priority/Circulators (with Zone Panel) Piped Off System Header Wiring Schematic for Heating Zone Circulators

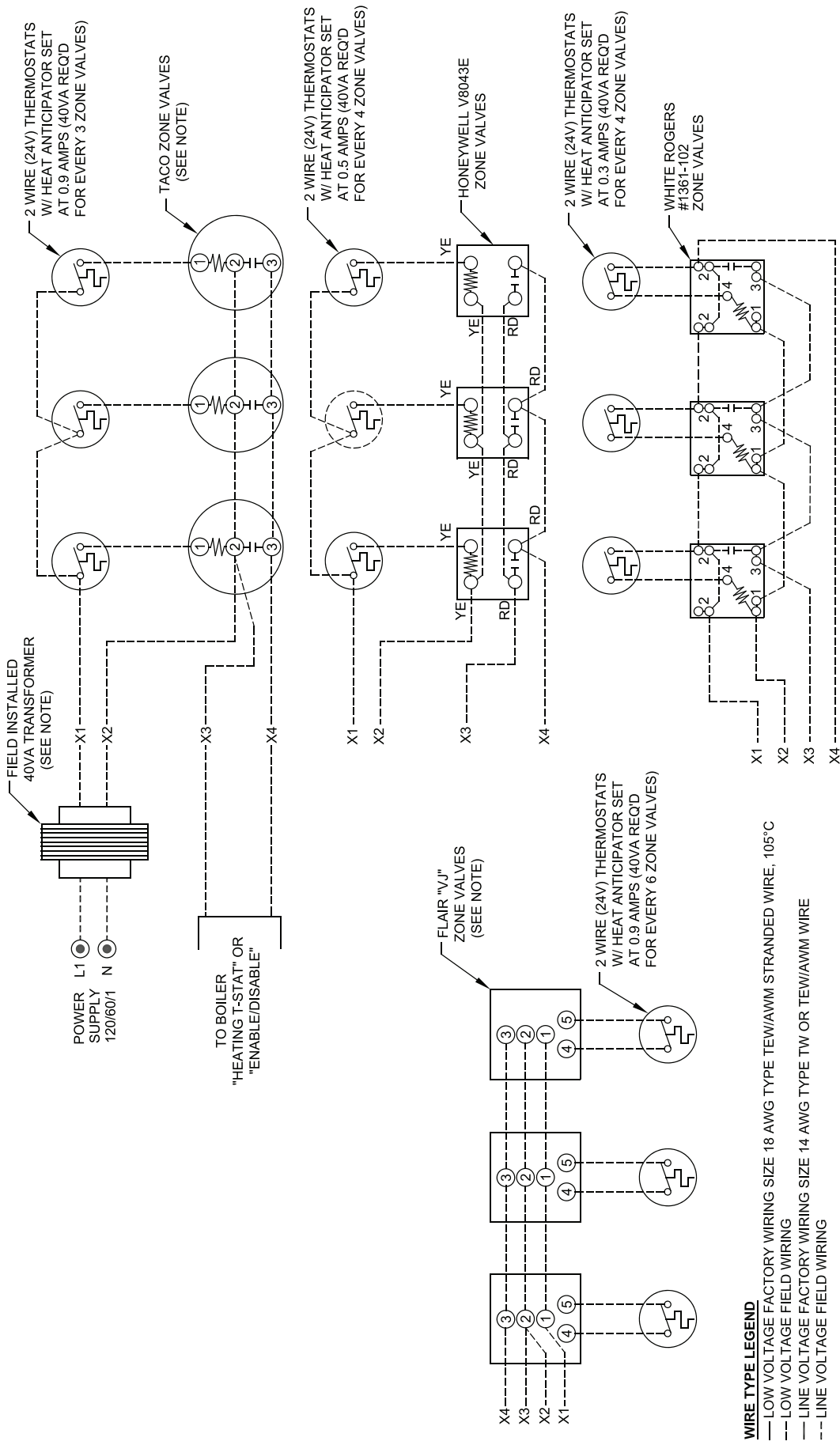

Figure 28C: Modified Wiring For DHW Priority When Using Low Flow Circulator Piped Off System Header - Heating (with Central Heating Zone Valves) Plus Alternately Piped Indirect Water Heater

VIII. Electrical (continued)

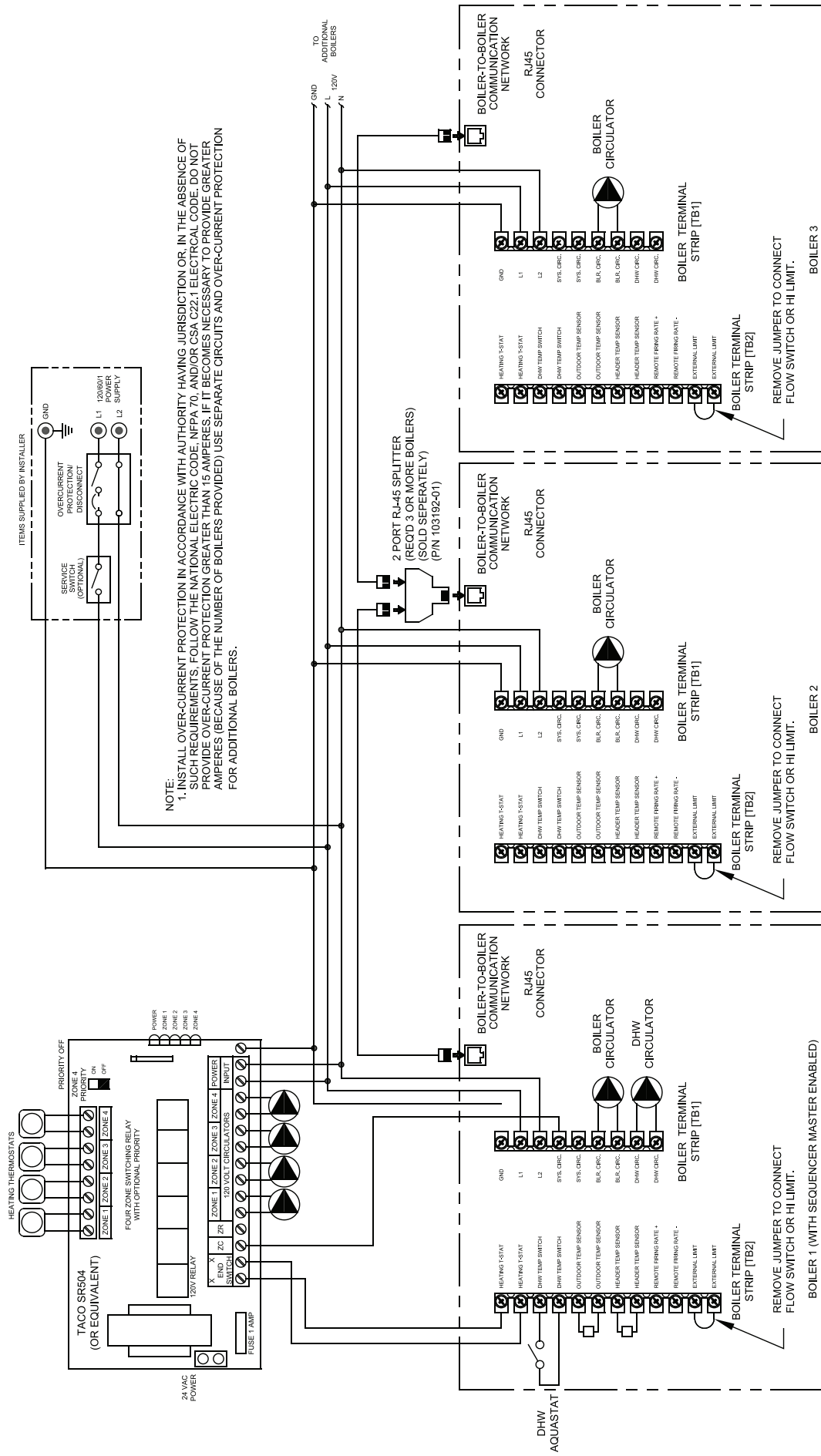

Figure 29A: Multiple Boiler Wiring Diagram
Internal R7910 Multiple Boiler Control Sequencer
(Three Boilers Shown, Typical Connections for up to Eight Boilers)

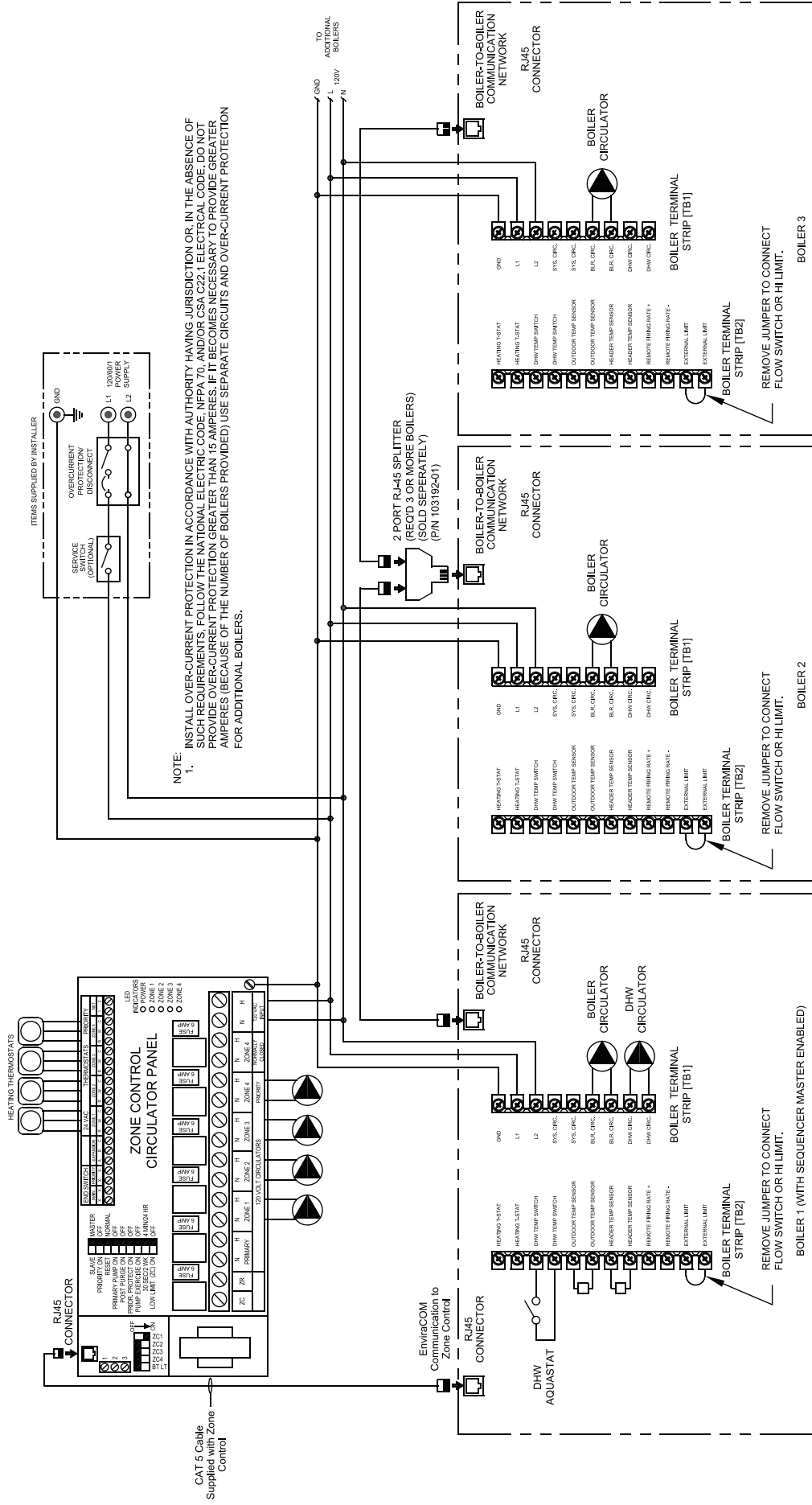

Figure 29B: Boiler-to-Boiler Communication (with Zone Control Circulator Panel)

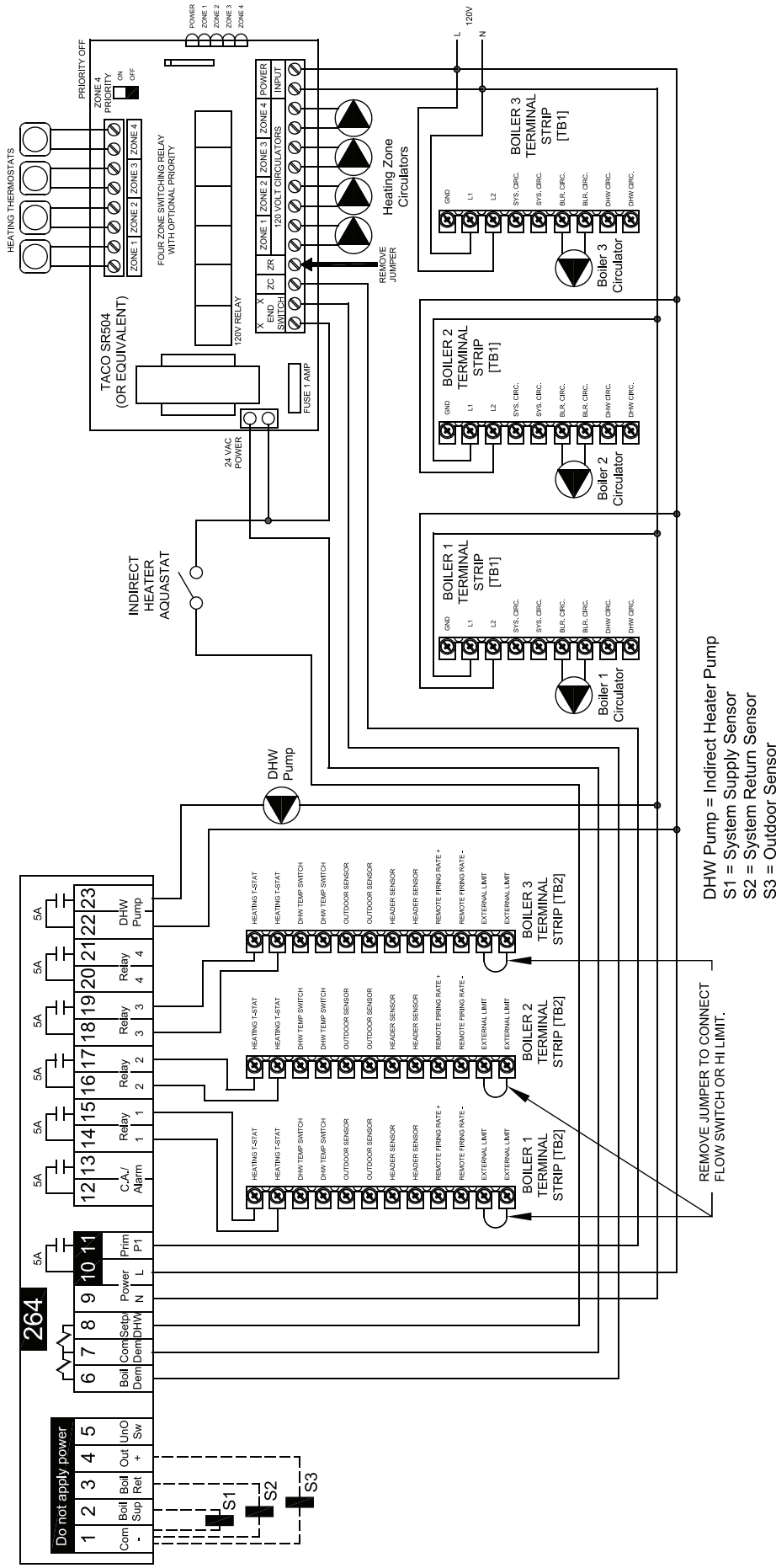

Figure 30B: Multiple Boiler Wiring Diagram w/Tekmar 264 Control
Tekmar 264 Based Control System (or equal)
Sequence of Operation

The Tekmar 264 Control (or equal) can control up to four (4) boilers and an Indirect Water Heater by utilizing stage firing. When a call for heat is received by the Tekmar 264 Control, the control will fire either one or more boilers in sequential firing mode to establish a required reset water temperature in the system supply main based on outdoor temperature. The boilers will modulate on their own based on each boiler's R7910™ Control and will target a setpoint temperature to supply enough input to the system main to satisfy the desired reset water temperature in the main established by the Tekmar 264 Control. When a call for Indirect Hot Water is generated to the Tekmar 264, the control will de-energize the zone pump control (ZC terminal), energize the Indirect pump and sequentially fire the boilers to establish a setpoint temperature in the main for the Indirect Heater using Priority. The Tekmar 264 Control will disable the stage firing and post purge the Indirect Pump to reduce the temperature in the Supply Main near the end of the Indirect Mode to a point where it will need to be when it changes back to Space Heating Mode. The Tekmar 264 Control also has the ability to rotate the lead-lag firing of the boilers to establish equal operating time for each boiler stage.

VIII. Electrical (continued)

G. External Multiple Boiler Control System

As an alternate to the R7910 Control internal sequencer, the R7910 Control also accepts an input from an external sequencer. Follow multiple boiler control system manufacturer (Honeywell, Tekmar, etc.) instructions to properly apply a multiple boiler control system. The Tekmar Model 264 and Model 265 based control wiring diagrams (Figures 30A and 30B) are provided as examples of typical multiple boiler control systems.

H. Multiple Boiler Operating Information

1. Required Equipment and Setup

- a. Header Sensor (P/N 101935-01 or 103104-01)

A header sensor must be installed and wired to the Master Sequencer “enabled” R7910 Controller. The header sensor is installed on the common system piping and provides blended temperature information to the Sequence Master. Refer to piping diagram Figure 23A on page 49 for installation location and Figure 31 or 32 for installation detail.

- b. RJ45 Splitters (P/N 103192-01)

RJ45 Splitters are required for installing communications between three or more boilers. When two boilers are connected the splitter is not required.

- c. Ethernet Cables

Ethernet cables are used to connect the boiler network together. These are standard “straight through” cables that can be purchased at electrical distributors.

Alternately, the network can be wired together by simply wiring terminal J3, Modbus 2, terminals A, B and V- between each boiler. Refer to Figures 26 and 27 terminal J3 for wiring location.

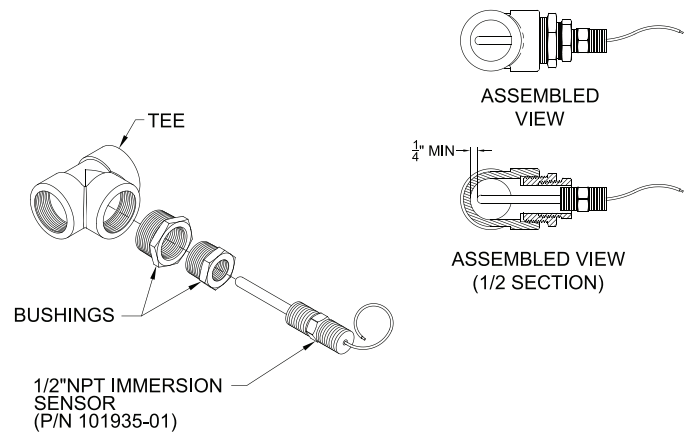

Figure 31: Recommended Direct Immersion Header Sensor Installation Detail

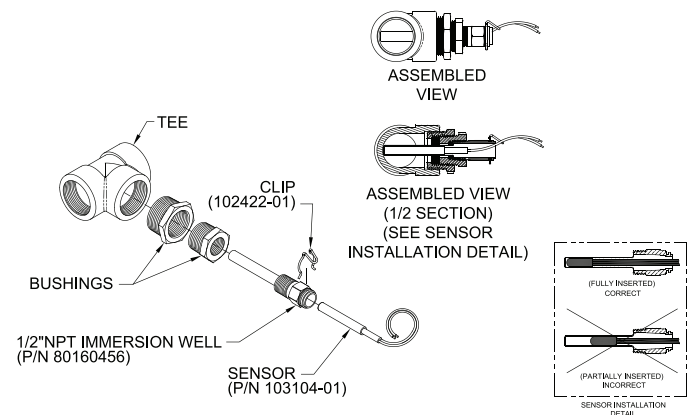
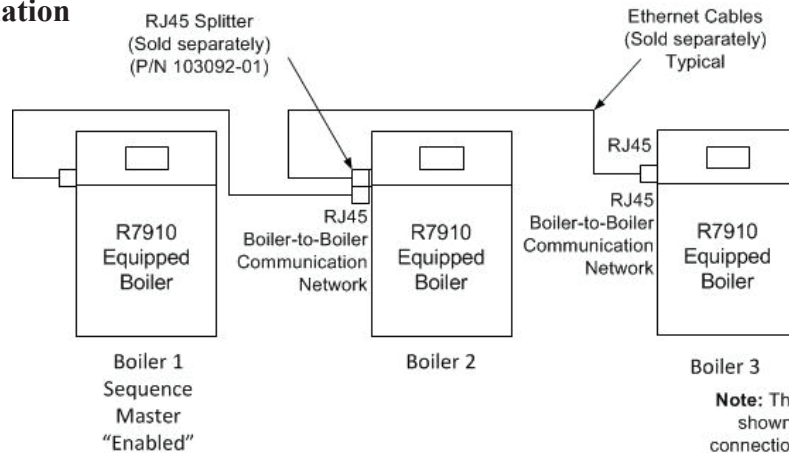

Figure 32: Alternate “Immersion” type Header Sensor Installation Detail

VIII. Electrical (continued)

G. Multiple Boiler Operating Information (continued)

Multiple Boiler Communication Network



Note: Three boilers shown, typical connections for up to eight boilers

TWO Boiler Communication Network

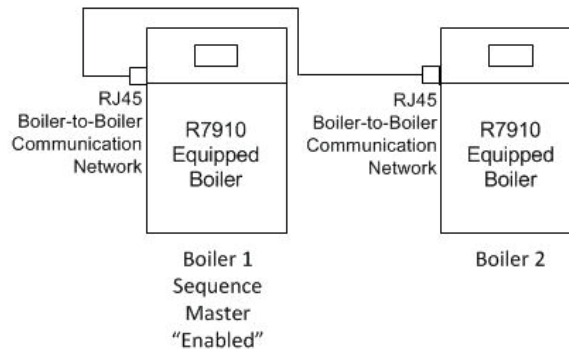

Figure 33: RJ45 Splitter Installation Detail

1. Required Equipment and Setup (continued)

d. Multiple Boiler Setup

Step	Description	Comments
1	Install and wire the Header Sensor	Wire the header sensor to low voltage terminal strip terminals "Header sensor". NOTE This step can not be skipped. The Sequence Master can not be "enabled" unless a Header Sensor is installed.
2	Install Ethernet Cables between boilers	Standard Ethernet type cables with RJ45 connectors are "plugged in" to the Boiler-to-Boiler Communication Network connection located on the side of the boiler. When more than two boilers are connected an RJ45 splitter may be used to connect the boilers. Refer to Figure 33.
3	Apply Power to All Boilers	
4	Set Unique Boiler Addresses	Assign all boilers a <u>unique</u> Boiler Address using any number from 1 through 8. WARNING When two boiler's addresses are the same undesirable simultaneous operation occurs.
5	Enable 1 Boiler Master	Enable <u>only one</u> R7910 Control's Sequencer Master. WARNING When more than one Sequencer Master is enable erratic behavior will result.
6	Power Down All Boilers	
7	Power Up Master Sequencer "Enabled" Boiler First	
8	Power Up Other Boilers	
9	Confirm Communication	From the Home Screen of the R7910 Control with the Master Sequencer "enabled", select the Status button. The Sequencer display shows the boiler address of the communicating boilers. Additionally, from the "Home" screen select the "Detail" button and then the "Networked Boilers" buttons to view boiler communication status. If a boiler is not shown, check Ethernet cable connections and confirm all boilers have unique addresses.

IX. System Start-up



WARNING

Explosion Hazard. Asphyxiation Hazard. Electrical Shock Hazard. Start-up of this boiler should be undertaken only by trained and skilled personnel from a qualified service agency. Follow these instructions exactly. Improper installation adjustment, service or maintenance can cause property damage, personal injury or loss of life.

- A. Verify that the venting, water piping, gas piping and electrical system are installed properly. Refer to installation instructions contained in this manual.
- B. Confirm all electrical, water and gas supplies are turned off at the source and that vent is clear of obstructions.
- C. Confirm that all manual shut-off gas valves between the boiler and gas source are closed.
- D. If not already done, flush the system to remove sediment, flux and traces of boiler additives. This must be done with the boiler isolated from the system. Fill entire heating system with water meeting the following requirements:

NOTICE

pH between 7.5 and 9.5.
If system contains aluminum components, pH must be less than 8.5
Chlorides < 50 ppm
Total Dissolved Solids - less than 2500 PPM
Hardness - 3 to 9 grains/gallon.

Pressurize the system to at least 20 psi (140 kPa).
Purge air from the system.



WARNING

Burn Hazard. The maximum operating pressure of this boiler is 30 psig (210 kPa), 50 psig (340 kPa), 60 psig (410 kPa), 80 psig (550 kPa) or 100 psig (689 kPa) depending on the model and safety relief valve option selected. Never exceed the maximum allowable working pressure on the heat exchanger ASME plate.

- E. Confirm that the boiler and system have no water leaks.

F. Prepare to check operation.

1. Obtain gas heating value (in Btu per cubic foot) from gas supplier.
2. Apex gas valves have inlet and outlet pressure taps with built-in shut off screw. Turn each screw from fully closed position three to four turns counterclockwise to open taps. Connect manometers to pressure taps on gas valve.

NOTICE

If it is required to perform a long term pressure test of the hydronic system, the boiler should first be isolated to avoid a pressure loss due to the escape of air trapped in the boiler.

To perform a long term pressure test including the boiler, ALL trapped air must first be removed from the boiler.

A loss of pressure during such a test, with no visible water leakage, is an indication that the boiler contained trapped air.

3. Temporarily turn off all other gas-fired appliances.
4. Turn on gas supply to the boiler gas piping.
5. Open the field installed manual gas shut-off valve located upstream of the gas valve on the boiler.
6. Confirm that the supply pressure to the gas valve is 13.5 in wc (3.4 kPa) or less. Refer to Table 19 on page 53 for minimum supply pressure.
7. Using soap solution, or similar non-combustible solution, electronic leak detector or other approved method, check that boiler gas piping valves, and all other components are leak free. Eliminate any leaks.



DANGER

Explosion Hazard. Do not use matches, candles, open flames or other ignition source to check for leaks.

8. Purge gas line of air.

G. Operating Instructions

Start the boiler using the Operating Instructions, see Figure 34. After the boiler is powered up, it should go through sequence of operation shown in Table 27 on page 81.

H. Purge Air From Gas Train

Upon initial start-up, the gas train will be filled with air. Even if the gas line has been completely purged of air,

IX. System Start-up (continued)

Apex Series Operating Instructions

FOR YOUR SAFETY READ BEFORE OPERATING/POUR VOTRE SECURITE LISEZ AVANT DE METTRE EN MARCHÉ

WARNING: If you do not follow these instructions exactly, a fire or explosion may result causing property damage, personal injury or loss of life.

AVERTISSEMENT: **Quiconque ne respecte pas à la lettre les instructions dans la présente notice risque de déclencher un incendie ou une explosion entraînant des dommages, des blessures ou la mort.**

A. This appliance does not have a pilot. It is equipped with an ignition device which automatically lights the burner. Do not try to light the burner by hand.

B. BEFORE OPERATING smell all around the appliance area for gas. Be sure to smell next to the floor because some gas is heavier than air and will settle on the floor.

WHAT TO DO IF YOU SMELL GAS:

- Do not try to light any appliance.
- Do not touch any electric switch; do not use any phone in your building.
- Immediately call your gas supplier from a neighbor's phone. Follow the gas supplier's instructions.
- If you cannot reach your gas supplier, call the fire department.

C. Use only your hand to turn the gas control knob. Never use tools. If the knob will not turn by hand, don't try to repair it, call a qualified service technician. Force or attempted repair may result in a fire or explosion.

D. Do not use this appliance if any part has been under water. Immediately call a qualified service technician to inspect the appliance and to replace any part of the control system and any gas control which has been under water.

A. Cet appareil ne comporte pas de veilleuse. Il est muni d'un dispositif d'allumage qui allume automatiquement le brûleur. Ne tentez pas d'allumer le brûleur manuellement.

B. AVANT DE FAIRE FONCTIONNER, reniflez tout autour de l'appareil pour déceler une odeur de gaz. Reniflez près du plancher, car certains gaz sont plus lourds que l'air et peuvent s'accumuler au niveau du sol.

QUE FAIRE SI VOUS SENTEZ UNE ODEUR DE GAZ:

- Ne pas tenter d'allumer d'appareil.
- Ne touchez à aucun interrupteur ; ne pas vous servir des téléphones se trouvant dans le bâtiment.
- Appelez immédiatement votre fournisseur de gaz depuis un voisin. Suivez les instructions du fournisseur.
- Si vous ne pouvez rejoindre le fournisseur, appelez le service des incendies.

C. Ne poussez ou tournez la manette d'admission du gaz qu'à la main ; ne jamais utiliser d'outil. Si la manette reste coincée, ne pas tenter de la réparer ; appelez un technicien qualifié. Le fait de forcer la manette ou de la réparer peut déclencher une explosion ou un incendie.

D. N'utilisez pas cet appareil s'il a été plongé dans l'eau, même partiellement. Faites inspecter l'appareil par un technicien qualifié et remplacez toute partie du système de contrôle et toute commande qui ont été plongés dans l'eau.

OPERATING INSTRUCTIONS/ INSTRUCTIONS DE FONCTIONNEMENT

1. STOP! Read safety information above on this label.
2. Set the thermostat to lowest setting.
3. Turn off all electric power to the appliance.
4. This appliance is equipped with an ignition device which automatically lights the burner. Do not try to light the burner by hand.
5. Turn the external boiler manual gas valve handle clockwise ↻ to close the gas supply.
6. Wait five (5) minutes to clear out any gas. Then smell for gas, including near the floor. If you smell gas, STOP! Follow "B" in the safety information above on this label. If you don't smell gas, go to the next step.
7. Turn the external boiler manual gas valve handle counterclockwise ↻ to open the gas supply.
8. Turn on all electric power to the appliance.
9. Set the thermostat to the desired setting.
10. If the appliance will not operate, follow the instructions "To Turn Off Gas To Appliance" and call your service technician or gas supplier.

OPEN/OUVERT

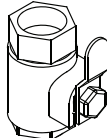

CLOSED/FERMÉ

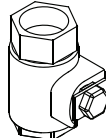

**EXTERNAL BOILER
MANUAL GAS VALVE**

**LA CHAUDIÈRE EXTERNE
MANUELLE DE CLAPET À GAZ**

1. ARRÊTEZ ! Lisez les instructions de sécurité sur la portion supérieure cette étiquette.
2. Réglez le thermostat à la température la plus basse.
3. Coupez l'alimentation électrique de l'appareil.
4. Cet appareil est équipé de l' dispositif d'allumage qui automobile allume maticallyle brûleur. Ne tentez pas d'allumer le brûleur manuellement.
5. Tourner la chaudière externe manuelle poignée ↻ en clapet à gaz dans le sens des aiguilles d'une montre pour fermer l'offre de gaz.
6. Attendre cinq (5) minutes pour laisser échapper tout le gaz. Reniflez tout autour de l'appareil, y compris près du plancher, pour déceler une odeur de gaz. Si vous seutez une odeur de gaz, ARRÊTEZ ! Passez à l'étape B des instructions de sécurité sur la portion supérieure de cette étiquette. S'il n'y a pas d'odeur de gaz, passez à l'étape suivante.
7. Tourner la chaudière externe manuelle compteur de poignée ↻ en clapet à gaz ouvrir dans le sens des aiguilles d'une montre le gaz approvisionnement.
8. Mettez l'appareil sous tension.
9. Réglez le thermostat à la température désirée.
10. Si l'appareil ne se met pas en marche, suivez les instructions intitulées « Comment couper l'admission de gaz de l'appareil » et appelez un technicien qualifié ou le fournisseur de gaz.

TO TURN OFF GAS TO APPLIANCE/ COMMENT COUPER L'ADMISSION DE GAZ DE L'APPAREIL

1. Set the thermostat to lowest setting.
2. Turn off all electric power to the appliance if service is to be performed.
3. Turn the external boiler manual gas valve handle clockwise ↻ to close gas supply.

1. Réglez le thermostat à la température la plus basse.
2. Coupez l'alimentation électrique de l'appareil s'il faut procéder à l'entretien.
3. Tourner la chaudière externe manuelle poignée ↻ en clapet à gaz dans le sens des aiguilles d'une montre pour fermer l'offre de gaz.

Figure 34: Operating Instructions

IX. System Start-up (continued)

Status	Control Action
Initiate	Power-up
Standby Delay	This state is entered when a delay is needed before allowing the burner control to be available and for sensor errors.
Standby	Boiler is not firing. There is no call for heat or there is a call for heat and the temperature is greater than setpoint.
Safe Startup	Tests flame circuit then checks for flame signal.
Drive Purge	Driving blower to purge rate setting and waiting for the proper fan feedback.
Prepurge	Purges the combustion chamber for the 10 second purge time.
Drive Light-off	Driving blower to light-off rate setting and waiting for the proper fan feedback.
Pre-ignition Test	Tests the safety relay and verifies that downstream contacts are off.
Pre-ignition	Energizes the igniter and checks for flame.
Direct Ignition	Opens main fuel valve and attempts to ignite the main fuel directly from the ignition source.
Running	Normal boiler operation. Modulation rate depends on temperature and setpoint selections and modulating control action.
Postpurge	Purges the combustion chamber for the 30 second purge time.
Lockout	Prevents system from running due to a detected problem and records fault in Lockout History.

it may take several tries for ignition before a flame is established. If more than 2 tries for ignition are needed, it will be necessary to press the reset button to restart the boiler. Once a flame has been established for the first time, subsequent calls for burner operation should result in a flame on the first try.

I. Check Burner Flame

Inspect the flame visible through the window. On high fire the flame should be stable and mostly blue (Figure 35). No yellow tipping should be present; however, intermittent flecks of yellow and orange in the flame are normal.

J. Check Gas Inlet Pressure

Check the inlet pressure and adjust if necessary. Verify that the inlet pressure is between the upper and lower limits shown on the rating plate with all gas appliances on and off.



WARNING

Asphyxiation Hazard. The outlet pressure for the gas valve has been factory set and requires no field adjustment. This setting is satisfactory for both natural gas and propane. Attempting to adjust the outlet pressure may result in damage to the gas valve and cause property damage, personal injury or loss of life.

K. Models APX425 and APX525 only: For LP Gas, perform procedure as described in Paragraph R “Field Conversion From Natural Gas to LP Gas” before starting Paragraph L “Checking/Adjusting Gas Input Rate”.

For natural gas, proceed to Paragraph L “Perform Combustion Test”.

L. Perform Combustion Test



WARNING

Asphyxiation Hazard. Each Apex Series boiler is tested at the factory and adjustments to the air fuel mixture are normally not necessary. Improper gas valve or mixture adjustments could result in property damage, personal injury or loss of life.



WARNING

Any gas valve adjustments (throttle and/or offset) specified herein and subsequent combustion data (%O₂, %CO₂, CO ppm) collection must be performed using a calibrated combustion analyzer. Failure to use combustion analyzer could result in property damage, personal injury or loss of life.

Table 21: Typical Combustion Settings, Natural Gas

Boiler Model	High Fire		Low Fire		CO, PPM
	% CO ₂	% O ₂	% CO ₂	% O ₂	
APX425	9.9 - 8.2	3.5 - 6.5	9.3 - 7.9	4.5 - 7.0	Less than 100 PPM
APX525	9.3 - 7.9	4.5 - 7.0	9.3 - 7.9	4.5 - 7.0	
APX625	9.1 - 8.5	4.9 - 6.0	9.1 - 7.5	4.9 - 7.7	
APX725	8.7 - 8.3	5.6 - 6.3	8.7 - 7.5	5.6 - 7.7	
APX825	9.3 - 7.9	4.5 - 7.0	9.3 - 7.9	4.5 - 7.0	

IX. System Start-up (continued)

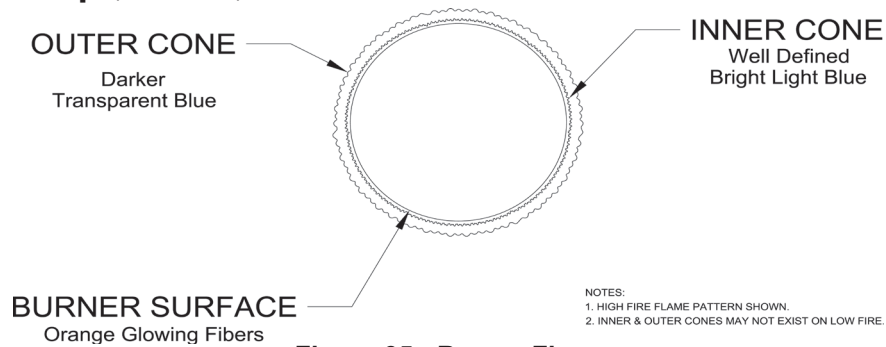

Figure 35: Burner Flame

Table 22: Typical Combustion Settings, LP Gas

Boiler Model	High Fire		Low Fire		CO, PPM
	% CO ₂	% O ₂	% CO ₂	% O ₂	
APX425	11.4 - 9.5	3.5 - 6.5	11.4 - 9.1	3.5 - 7.0	Less than 100 PPM
APX525	10.8 - 9.1	4.5 - 7.0	10.8 - 9.1	4.5 - 7.0	
APX625	9.6 - 9.2	6.3 - 7.0	9.6 - 8.0	6.5 - 8.8	
APX725	9.6 - 9.2	6.3 - 7.0	9.6 - 8.0	6.5 - 8.8	
APX825	10.8 - 9.1	4.5 - 7.0	10.8 - 9.1	4.5 - 7.0	

1. Remove flue temperature sensor from vent connector (see Figure 9 on page 22) and insert combustion analyzer probe through flue temperature sensor silicon cap opening. If required, also remove the flue temperature sensor silicon cap and insert the analyzer probe directly into flue sensor port. Reinstall the sensor and the cap upon combustion testing completion.
2. Verify O₂ (or CO₂) and CO are within limits specified in Table 21 (natural gas) or Table 22 (LP gas) at both high and low fire as described in the following steps.
 - a. Lock boiler in high fire and allow boiler to operate for approximately 5 minutes before taking combustion readings. To lock boiler in high fire, from the home screen, press “Adjust”, “Adjust”, “Login”, “000”. Enter the password “086” and press return arrow to close the keypad. Press “Save”, “Adjust”, “High” to lock boiler in high fire.

- b. If high fire O₂ is too low (CO₂ is too high), increase O₂ (decrease CO₂) by turning the throttle screw clockwise in 1/4 turn increments and checking the O₂ (or CO₂) after each adjustment. If boiler is equipped with 2 gas valves, throttle screw adjustments must be done to both gas valves equally and simultaneously. Refer to Figure 36 for location of throttle screw. Verify CO is less than 100 ppm.
- c. If high fire O₂ is too high (CO₂ is too low), decrease O₂ (increase CO₂) by turning the throttle screw counter-clockwise in 1/4 turn increments and checking the O₂ (or CO₂) after each adjustment. If boiler is equipped with 2 gas valves, throttle screw adjustments must be done to both gas valves equally and simultaneously. Refer to Figure 36 for location of throttle screw. Verify CO is less than 100 ppm.
- d. Lock boiler in low fire and allow boiler to operate for approximately 5 minutes before taking combustion readings. Press “Low” to lock boiler in low fire.

WARNING

Make sure that all adjustments at high fire are made with the throttle, not offset screw (see Figure 36). The offset screw has been factory set using precision instruments and must never be adjusted in the field unnecessarily. Attempting to adjust the offset screw unnecessary could result in damage to the gas valve and may cause property damage, personal injury or loss of life.

WARNING

Asphyxiation Hazard. Offset screw is adjusted at the factory to the specification. DO NOT touch the offset screw if measured low fire O₂ (or CO₂) is within limits specified in Table 21 or 22.

- e. If low fire O₂ is too low (CO₂ is too high), increase O₂ (decrease CO₂) by turning offset screw counterclockwise in less than 1/8 turn increments and checking the O₂ (or CO₂) after each adjustment. If boiler is equipped with 2 gas

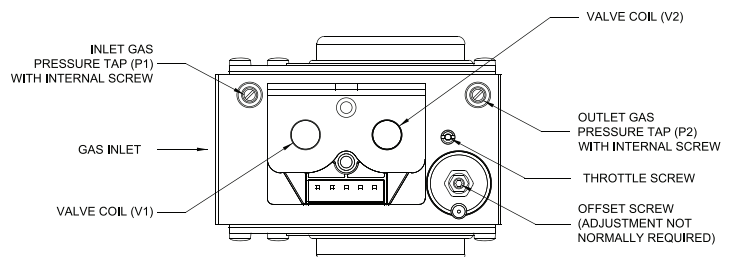

Figure 36: Gas Valve Detail

IX. System Start-up (continued)

valves, offset screw adjustments must be done to both gas valves equally and simultaneously. Refer to Figure 36 for location of offset screw. Verify CO is less than 100 ppm.

- f. If low fire O₂ is too high (CO₂ is too low), decrease O₂ (increase CO₂) by turning offset screw clockwise in less than 1/8 turn increments and checking the O₂ (or CO₂) after each adjustment. If boiler is equipped with 2 gas valves, offset screw adjustments must be done to both gas valves equally and simultaneously. Refer to Figure 36 for location of offset screw. Verify CO is less than 100 ppm.



WARNING

Asphyxiation Hazard. Install flue temperature sensor and sensor cap into two-pipe vent connector port upon completion of combustion test. Failure to properly secure the flue temperature sensor into the port could lead to property damage, personal injury or loss of life.

3. **Reinstall flue temperature sensor** with sensor cap into two-pipe vent adapter.
 - a. Inspect flue temperature sensor cap for degradation. Replace if needed.
 - b. Use Molykote 111 grease to lubricate outer surface of two-pipe vent adapter stub where flue temperature sensor is inserted. Also lubricate tip of flue temperature sensor. Reinstall flue temperature sensor with cap into two-pipe vent adapter.
4. **Return boiler** to normal operating mode by pressing “Auto”.

M. Checking / Adjusting Gas Input Rate

1. **Turn** off gas supply to all appliances other than gas-fired boiler.
2. **Lock the boiler in high fire**, following Step 3a in Paragraph L.
3. **Clock gas meter** for at least 2 revolutions of the dial, typically labeled ½ or 1 cubic foot per revolution on the gas meter.
4. **Determine gas flow rate** in cubic feet per hour based on elapsed time for 2 revolutions.

Example:

Using a meter with dial labeled 1 cubic foot per revolution, measured time is 72 seconds for 2 Revolutions, i.e. 36 seconds per 1 cubic foot.

Calculate hourly gas flow rate:

$$3600 \text{ sec/hr} \div 36 \text{ sec/cu ft} = 100 \text{ cu ft/hr}$$

5. **Obtain gas-heating value** (BTU per cubic foot) from gas supplier.
6. **Multiply** hourly gas flow rate by gas heating value to determine the boiler input rate, BTU/hr

Example:

Natural gas heating value provided by local gas utility is 1050 BTU per cubic foot.

Measured and calculated hourly gas flow rate is 100 cu ft/hr.

Measured boiler input rate is:

$$100 \text{ cu ft/hr} * 1050 \text{ BTU/cu ft} = 105,000 \text{ BTU/hr}$$

7. **Verify measured input rate** is within 88% to 100% of the max. input listed on the boiler rating label.
8. **If measured input is too high**, reduce maximum modulation fan speed (either central heat or domestic hot water, depending on source of call for heat) in increments of 50 RPM and check the input rate after each adjustment. Follow instructions in Section X. “Operation” to adjust the maximum modulation fan speed.
9. **If measured input is too low**, increase maximum modulation fan speed (either central heat or domestic hot water, depending on source of call for heat) in increments of 50 RPM and check the input rate after each adjustment. Follow instructions in Section X “Operation” to adjust the maximum modulation fan speed.
10. **Return boiler to normal operating mode** by pressing “Auto”.
11. **Return** other gas-fired appliances to previous condition of use.

N. Test Safety Limits Controls

1. **Test the ignition system safety shut-off** by disconnecting the flame sensor connector (black plug with orange wire) from the flame ionization electrode. See Figure 27. The boiler must shut down and must not start with the flame sensor disconnected.
2. **Test the flow switch** by disabling the primary loop circulator. The boiler must not start if flow is not present.
3. **Test any other external limits** or other controls in accordance with the manufacturer’s instructions.

O. Check Thermostat Operation

Verify that the boiler starts and stops in response to calls for heat from the heating thermostat and indirect water heater thermostat. Make sure that the appropriate circulators also start and stop in response to the thermostats.

IX. System Start-up (continued)

P. Adjust Supply Water Temperature

As shipped, the heating set point supply temperature is set to 180°F (82.2°C) and, indirect water heater set point supply temperature is set to 170°F (76.7°C). If necessary, adjust these to the appropriate settings for the type of system to which this boiler is connected. See Section X “Operation” (parameter table on page 89) of this manual for information on how to adjust supply setpoint.

Q. Adjust Thermostats

Adjust the heating and indirect water heater thermostats to their final set points.

R. Field Conversion From Natural Gas to LP Gas

Apex models APX425 and APX525 are factory shipped as natural gas builds and can be field converted to LP gas. Follow steps below for field conversion from natural gas to LP Gas.

Models APX625, APX725 and APX825 are factory shipped as either natural gas build or LP gas build. Field conversions of models APX625, APX725 and APX825 are not permitted.

1. **Conversion** of Apex models APX425 and APX525 from one fuel to another is accomplished using the throttle screw on the gas valve. Figure 36 “Gas Valve Detail” shows the location of the throttle screw on the valve. Locate the throttle screw on the boiler being converted.



WARNING

Explosion Hazard. Asphyxiation Hazard. This conversion should be performed by a qualified service agency in accordance with the manufacturer’s instructions and all applicable codes and requirements of the authority having jurisdiction. If the information in these instructions is not followed exactly, a fire, an explosion or production of carbon monoxide may result causing property damage, personal injury, or loss of life. The qualified service agency is responsible for proper conversion of these boilers. The conversion is not proper and complete until the operation of the converted appliance is checked as specified in this manual.

2. **If conversion is being made on a new installation**, install the boiler in accordance with the installation instructions supplied with the boiler. If an installed boiler is being converted, connect the new gas supply to the boiler, check for gas leaks, and purge the gas line up to the boiler

Table 23: Approximate Number of Clockwise Throttle Screw Turns for LP Conversion

Boiler Model	Gas Valve	Approximate Throttle Screw Turns
APX425	GB-057 HO ($\frac{3}{4}$ " NPT)	1 $\frac{3}{4}$
APX525	GB-057 HO ($\frac{3}{4}$ " NPT)	1
APX625	GB-ND057 D01 S00 XP ($\frac{3}{4}$ " NPT)	Factory LP Builds
APX725		
APX825		

in accordance with the *National Fuel Gas Code*, ANSI Z223.1/NFPA 54 and/or *Natural Gas and Propane Installation Code*, CAN/CSA B149.1 or the requirements of the authority having jurisdiction.

3. **Before attempting to start the boiler**, make the number of turns to the throttle screw called for in Table 23.
4. **Attempt to start the boiler** using the Operating Instructions located inside the lower front cover of the boiler. If the boiler does not light on the first try for ignition, allow to boiler to make at least four more attempts to light. If boiler still does not light, turn the throttle counter clockwise in 1/4 turn increments, allowing the boiler to make at least three tries for ignition at each setting, until the boiler lights.



WARNING

Asphyxiation Hazard. The throttle adjustments shown in Table 23 are approximate. The final throttle setting must be found using a combustion analyzer. Leaving the boiler in operation with a CO level in excess of the value shown in Table 22 could result in injury or death from carbon monoxide poisoning.

5. **After the burner lights**, complete all steps outlined in Paragraph L “Perform Combustion Test” and Paragraph M “Checking/Adjusting Gas Input Rate” before proceeding.
6. **Verify** that the gas inlet pressure is between the upper and lower limits shown in Table 19 on page 53 with all gas appliances (including the converted boiler) both on and off.

IX. System Start-up (continued)



WARNING

Asphyxiation Hazard. These instructions include a procedure for adjusting the air-fuel mixture on this boiler. This procedure requires a combustion analyzer to measure the O₂ (or CO₂) and Carbon Monoxide (CO) levels in flue gas. Adjusting the air-fuel mixture without a proper combustion analyzer could result in unreliable boiler operation, personal injury, or death due to carbon monoxide poisoning.

7. A label sheet is provided with the boiler for conversions from natural gas to LP gas. Once conversion is completed, apply labels as follows:
 - a. Apply the “Rating Plate Label” adjacent to the rating plate.
 - b. Apply the “Gas Valve Label” to a conspicuous area on the gas valve.
 - c. Apply the “Boiler Conversion Label” to a conspicuous surface on, or adjacent to, the outer boiler jacket. Fill in the date of the conversion and the name and address of the company making the conversion with a permanent marker.

S. Correcting Throttle Screw Mis-Adjustment (if required)

Apex boilers are fire tested at factory and gas valve throttle screws are preset. However, if boiler does not start when first turned on, and, the problem cannot be remedied following “Help” prompts on the boiler control display, it may be necessary to reset and readjust the throttle screw according to the following instructions.

1. **Fully close throttle** by turning throttle screw clockwise until it fully stops.

Table 24A: Approximate Throttle Screw Adjustment Values from Fully Closed Position, Natural Gas

Boiler Model	Throttle Position (Number of Counter-clockwise Turns from Fully Closed Position)
APX425	4 & 3/4
APX525	4 & 3/4
APX625	6
APX725	10
APX825	7 & 1/2

Table 24B: Approximate Throttle Screw Adjustment Values from Fully Closed Position, LP Gas

Boiler Model	Throttle Position (Number of Counter-clockwise Turns from Fully Closed Position)
APX425	3
APX525	3 & 3/4
APX625	6
APX725	10
APX825	7 & 1/2

2. **Open throttle screw** counter-clockwise the number of full (360 degrees) and partial turns listed in Table 24A for natural gas or Table 24B for LP gas.
3. **Follow instructions in Section L** “Perform Combustion Test” to verify O₂ (or CO₂) is within the range specified in Table 21 for natural gas or Table 22 for LP gas at both high fire and low fire.



WARNING

The throttle adjustment values shown in Table 24A and Table 24B are approximate. The final throttle setting must be found using a combustion analyzer.



WARNING

Asphyxiation Hazard. If the throttle is very far out of adjustment on the “rich” (counter-clockwise) side, the boiler burner may be running at 0% excess air or even with air deficiency. Operating the boiler in this condition may cause property damage, personal injury or loss of life.

At 0% excess air the CO₂ readings will be either 11.9% CO₂ for natural gas or 13.8% CO₂ for LP gas (O₂ will be 0%) and CO level will be extremely high (well over 1000 PPM).

If the burner operates with air deficiency, the following phenomena may be observed:

- % CO₂ will actually drop (% O₂ will increase) as the throttle is turned counter-clockwise
- % CO₂ will actually increase (% O₂ will drop) as the throttle is turned clockwise

If the boiler appears to operate with air deficiency, shut down the boiler and follow instructions in Paragraph S “Correcting Throttle Screws Mis-Adjustment. Then, use a combustion analyzer to verify and adjust O₂ (or CO₂) and CO to values shown in Table 21 for natural gas or Table 22 for LP gas.

IX. System Start-up (continued)

T. Controls Startup Check List

The Control is factory programmed with default parameters. Before operating the boiler, these parameters must be checked and adjusted as necessary to conform to the site requirements. Follow the steps below, making selections and adjustments as necessary to ensure optimal boiler operation.

No.	Title	Terminal	Description
1	Check Wiring	1 & 2	Is the heating thermostat connected? Insure this is "dry", non-powered input.
		2 & 3	Is an Indirect Water Heater (IWH) providing a boiler heat demand?
		5 & 6	Is an Outdoor Air sensor used? If no, select outdoor sensor type "not installed" under system menu.
		7 & 8	Is a header sensor used? If yes, refer to step 10 below to activate this feature.
		9 & 10	Is a Remote 4-20mA required for a Energy Management System or external multiple boiler control? If used see step 9 below to activate this input.
		11 & 12	Is a Flow Switch (where applicable) and/or External Limit used? Remember to remove factory-installed jumper.
		LWCO Plug	Is a LWCO required? Check installation of the LWCO.
From the Home Screen press the Adjust button and login to access the adjust mode screens (if required, refer to X. Operation Section, "Entering Adjustment Mode" Paragraph G, 1 for login instructions). The following parameters should be reviewed:			
No.	Menu	Parameter	Description
2	System Setup	Warm Weather Shutdown	Selecting "Enable" will restrict boiler start during warm weather (only if an outdoor air temperature sensor is installed).
		Warm Weather Shutdown Setpoint	Use this setting to adjust the temperature that the WWSD function will shut boiler off.
3	Modulation Setup	Boiler Type	WARNING Confirm that the correct boiler model is shown. Stop installation and contact factory if the wrong boiler model is shown.
4	Pump Setup	System Pump	Ensure that the pump parameter selections are correct for your heating system. Refer to Paragraph G. Adjusting Parameters, Pump Setup Menu for additional information.
		Boiler Pump	
		Domestic Pump	
5	Contractor Setup	Contractor Name	Enter <u>your contact information</u> , name, address, and phone number on this screen. In the event of a fault or the need to adjust a setting the display will direct the homeowner to you.
		Address	
		Phone	
6	Manual Control	Manual Speed Control	Use the "High and "Low" options to force the boiler to high fire and low fire for combustion testing.
7	Central Heat	Setpoint	Ensure Setpoint, (firing rate target temperature) is correct for your type of radiation.
		Setback Setpoint	Check the setting for the central heat setpoint when the T-Stat "Sleep" or "Away" Setback mode is entered (if EnviraCOM Setback thermostat is used).
8	DHW	Setpoint	Ensure Setpoint, (firing rate target temperature) is suitable for the IWH requirements.
		Setback Setpoint	Check the setting for the DHW setpoint when the T-Stat "Sleep" or "Away" Setback mode is entered (if EnviraCOM Setback thermostat is used).
9	Remote 4-20mA	Modulation Source	Set to 4-20mA when an external multiple boiler controller is connected to the system.
		Setpoint Source	Set to 4-20mA when a Energy Management system is sending a "remote" setpoint.
10	Sequencer	Master Slave	Refer to Sequencer Master Setup Section X, G if multiple boilers are installed at this site.

X. Operation

A. Overview

1. R7910 Controller

The R7910 Controller (Control) contains features and capabilities which help improve heating system operation, and efficiency. By including unique capabilities, the Control can do more, with less field wiring, and fewer aftermarket controls and components – improving the operation of both new and replacement boiler installations.

2. Advanced Touch Screen Display

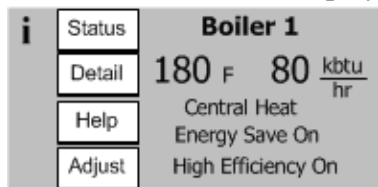

Home Screen

Boiler status and setup selections are available from an easy to use, dual color, LCD Touch Screen Display. Over one hundred helpful information screens are provided to explain status information and setup functions. In the event of a fault condition the user is guided by “blinking” touch buttons to Help screens that explain the problem cause and corrective action. Operation evaluation and problem-solving is enhanced by historical capability including graphic trends, lockout history records as well as boiler and circulator cycle counts and run time hours.

3. Advanced Modulating Control

The Control modulates the boiler input by varying the fan speed. As the fan speed increases, so does the amount of fuel gas drawn into the blower. As a result, a fairly constant air-fuel ratio is maintained across all inputs. The Control determines the input needed by looking at both current and recent differences between the measured temperature and the setpoint temperature. As the measured temperature approaches the setpoint temperature, the fan will slow down and the input will drop. The Control also utilizes boiler return water and flue gas temperatures to adjust fan speed.

4. HeatMatch™ Software

When the boiler is installed with a Sage Zone Control Panel (Zone Control) into a multiple zone home the Control uses a patent pending HeatMatch Software to improve home comfort, increase component life and save energy. The R7910 Controller with the Zone Control detects active (turned “on”) zones, totals btu/hrs expected and limits the boiler firing rate to “match” actual home demand. Instead of simply firing to 100% in response to a cold supply water temperature the Control combines heat matching with supply water temperature control. The result is longer run times, dramatic reduction in boiler excessive cycling and higher operating efficiency. Avoiding extra cycling saves customer fuel dollars (pre and post purge sends heat up stack) and saves wear and tear on the boiler. Lowering the boiler’s firing rate saves fuel dollars by increasing the amount of flue gas condensation, always the goal of condensing boiler installations.

5. Built-in Safety Control

The Control includes safety controls designed to ensure safe and reliable operation. In addition to flame safety controls the Control includes supply water temperature, differential water temperature, and stack temperature safety limits and stepped modulation responses. Boiler modulation is adjusted when required to help avoid loss of boiler operation due to exceeding limits. Additionally, the Control accepts the field installation of optional auxiliary safety limits.

6. Outdoor Air Reset

When selected the modulation rate setpoint is automatically adjusted based on outside air temperature, time of day and length of demand (boost) settings. Outdoor air “reset” setpoint saves fuel by adjusting the water temperature of a heating boiler lower as the outside air temperature increases.

7. Warm Weather Shutdown (WWSD)

Some boilers are used primarily for heating buildings, and the boilers can be automatically shutdown when the outdoor air temperature is warm. When outside air temperature is above the WWSD setpoint, this function will shut down the boiler and system pump.

8. Energy Management System (EMS) Interface

The control accepts a 4-20mA dc input from the EMS system for either direct modulation rate or setpoint. A factory configured RS485 Modbus interface is available for Energy Management System (EMS) monitoring when not used for Multiple Boiler Sequencer Peer-To-Peer Network. Consult factory if this interface must be used in addition to the boiler Peer-to-Peer Network.

9. Circulator Control

The Control may be used to sequence the domestic hot water, boiler and system circulators. Service rated relay outputs are wired to a line voltage terminal block for easy field connection. Simple parameter selections allow all three pumps to respond properly to various hydronic piping arrangements including either a boiler or primary piped indirect water heater. Circulators are automatically run for a 20 second exercise period after not being used for longer than 7 days. Circulator exercise helps prevent pump rotor seizing.

10. Multiple Boiler Sequencer Peer-To-Peer Network

The Control includes state-of-the-art modulating lead-lag sequencer for up to eight (8) boilers capable of auto rotation, outdoor reset and peer-to-peer communication. The peer-peer network is truly “plug and play”. Communication is activated by simply connecting a RJ45 ethernet cable between boilers. The Control provides precise boiler coordination by sequencing boilers based on both header water temperature and boiler modulation rate. For example, the lead boiler can be configured to start a lag boiler after operating at 50% modulation rate for longer than an adjustable time. The boilers are modulated in “unison” (parallel) modulation rate to ensure even heat distribution.

X. Operation B. Supply Water Temperature Regulation (continued)

11. Modbus Communication Interface

A factory configured RS485 Modbus interface is available for Energy Management System (EMS) monitoring when not used for Multiple Boiler Sequencer Peer-To-Peer Network. Consult factory if this interface must be used in addition to the boiler Peer-to-Peer Network.

B. Supply Water Temperature Regulation

1. Priority Demand

The Control accepts a call for heat (demand) from multiple places and responds according to its "Priority". When more than 1 demand is present the higher priority demand is used to determine active boiler settings. For example, when Domestic Hot Water (DHW) has priority the setpoint, "Diff Above", "Diff Below" and pump settings are taken from DHW selections. Active "Priority" is displayed on the "Boiler Status" screen.

Table 25: Order of Priority

Priority	Status Screen Display	Boiler Responding to:
1st	Sequencer Control	The boiler is connected to the peer-to-peer network. The boiler accepts demand from the Sequencer Master.
2nd	Domestic Hot Water	DHW call for heat is on and selected as the priority demand. DHW is always higher priority than Central Heat. It also has higher priority than the Sequencer Control when DHW priority is "enabled" and "Boiler Piped" IWH is selected.
3rd	Central Heat	Central Heat call for heat is on and there is no DHW demand or DHW priority time has expired.
4th	Auxiliary Heat	Auxiliary Heat call for heat is on and there is no Central Heat or DHW demand. (NOTE: May be user selected to be higher priority than Central Heat.)
5th	Frost Protection	Frost Protection is active and there is no other call for heat. Frost protection will be a higher priority than Sequencer Control if the Sequence Master has no active call for heat.
6th	Warm Weather Shutdown (WWSD)	WWSD is active and the boiler will not respond to central heat demands. DHW demand is not blocked by WWSD.
7th	Standby	There is no demand detected.

2. Setpoint Purpose

The Control starts and stops the boiler and modulates the boiler input from minimum (MBH) to maximum (MBH) in order to heat water up to the active setpoint. The setpoint is determined by the priority (Central Heat or Domestic Hot Water) and as described in the following paragraphs.

3. Central Heat Setpoint

Upon a Central Heat call for heat the setpoint is either the user entered Central Heat Setpoint, or is automatically adjusted by a thermostat's "Sleep" or "Away" modes and/or Outdoor Air Reset or, an Energy Management System (EMS) supplied 4-20mA dc setpoint.

4. Auxiliary Heat Setpoint

Auxiliary Heat is a second heating demand that may be used to serve either lower temperature radiation or warmer heat demands such as fan coils. Upon an Auxiliary Heat call for heat the setpoint is either the user entered Auxiliary Heat Setpoint or is automatically adjusted as a thermostat's "sleep" or, Away Modes or, Outdoor Air Reset.

5. Outdoor Air Reset

If an outdoor temperature sensor is connected to the boiler and Outdoor Reset is enabled, the Central Heat and Auxiliary Heat setpoints will automatically adjusted downwards as the outdoor temperature increases. When the water temperature is properly matched to heating needs there is minimal chance of room air temperature overshoot. Excessive heat is not sent to the room heating elements by "overheated" (supply water temperature maintained too high a setting) water. Reset control saves energy by reducing room over heating, reducing boiler temperature & increasing combustion efficiency and, reducing standby losses as a boiler and system piping cool down to ambient following room over heating.

6. Boost Time

When the Central Heat Setpoint is decreased by Outdoor Air Reset settings the Boost function can be enabled to increase the setpoint in the event that central heat demand is not satisfied for longer than the Boost Time minutes. The Boost feature increases the operating temperature setpoint by 10°F (5.6°C) every 20 minutes (field adjustable) the central heat demand is not satisfied. This process will continue until heat demand is satisfied (indoor air is at desired temperature). Once the heat demand is satisfied, the operating setpoint reverts to the value determined by the Outdoor Air Reset settings. If Boost Time is zero, then the boost function is not used.

7. Domestic Hot Water (DHW) Setpoint

Upon a DHW call for heat the setpoint is either the user entered DHW setpoint or the Thermostat's "Sleep" or "Away" DHW setpoint. The optimal value of this setpoint is established based on the requirements of the indirect water heater.

8. Domestic Hot Water Priority (DHWP)

Some boilers are used primarily for building space heating, but also provide heat for the domestic hot water users. When the outdoor temperature is warm, the outdoor reset setpoint may drop lower than a desirable domestic hot water temperature. Also, often it is required to quickly recover the indirect water heater. When DHWP is enabled, heating circulators are stopped, the domestic circulator is started and the domestic hot water setpoint is established in response to a domestic hot water demand. Priority protection is provided to allow the heating loop to be serviced again in the event of an excessively long domestic hot water call for heat.

X. Operation C. Boiler Protection Features (continued)

9. “Setback” Setpoints

User adjustable Thermostat “Sleep” or “Away” Setback Setpoints are provided for both Central Heat and DHW demands. The Setback setpoint is used when the EnviraCOM thermostat is in “leave” or “sleep” modes. When setback is “on”, the thermostat setback setpoint shifts the reset curve to save energy while the home is in reduced room temperature mode. The Honeywell VisionPro IAQ (part number TH9421C1004) is a “setback” EnviraCOM enabled thermostat.

C. Boiler Protection Features

1. Supply Water Temperature High Limit

The boiler is equipped with independent automatic reset and a manual reset high limit devices. A supply manifold mounted limit device provides the automatic reset high limit. The automatic high limit is set to 200°F (93.3°C). The control monitors a supply water temperature sensor that is also mounted in the supply water manifold and an internal, manual reset high limit. If the temperature exceeds 210°F (98.9°C), a manual reset hard lockout results. If the boiler is responding to the internal Multiple Boiler Control Sequencer, Header Sensor or, an External EMS demand, and the supply water temperature increases above 190° F (87.7° C), the control begins to reduce the blower maximum speed setting and the temperature increases to 200° F (93.3° C), a forced recycle results. Additionally, if the supply temperature rises faster than the degrees Fahrenheit per second limit, a soft lockout is activated.

2. High Differential Temperature Limit

The Control monitors the temperature difference between the return and supply sensors. If this difference exceeds 43°F (23.9°C), the control begins to reduce the maximum blower speed. If temperature difference exceeds 53°F (29.4°C), a forced boiler recycle results. If the temperature difference exceeds 63°F (35°C), the control will shut the unit down. The unit will restart automatically once the temperature difference has decreased and the minimum off time has expired.

3. Return Temperature Higher Than Supply Temperature (Inversion Limit)

The Control monitors the supply and return temperature sensors. If the return water temperature exceeds the supply water temperature for longer than a limit time delay, the Control shuts down the boiler and delays restart. If the inverted temperature is detected more than five times, the boiler manual reset Hard Lockout is set. This condition is the result of incorrectly attaching the supply and return piping.

4. External Limit

An external limit control can be installed between terminals 11 and 12 on the low voltage terminal strip. Be sure to remove the jumper when adding an external limit control to the system. If the external limit opens,

the boiler will shut down and an open limit indication and error code are provided. If the limit installed is a manual reset type, it will need to be reset before the boiler will operate.

5. Boiler Mounted Limit Devices

The Control monitors individual limit devices: pressure switch, high limit device, condensate level switch, Thermal Link, Burner Door Thermostat with manual reset, flow switch, fuel gas pressure switches (optional) and external limit (optional). If any of these limits open, the boiler will shut down and an individual open limit indication is provided.

6. Stack High Limit

The Control monitors the flue gas temperature sensor located in the vent connector. If the flue temperature exceeds 184°F (84.4°C), the control begins to reduce the maximum blower speed. If the flue temperature exceeds 194°F (90.0°C), a forced boiler recycle results. If the flue temperature exceeds 204°F (95.6°C), the control activates a manual reset Hard Lockout.

7. Ignition Failure

The Control monitors ignition using a burner mounted flame sensor. In the event of an ignition failure:

- Model APX425 - the control retries 5 times and then goes into soft lockout for one hour.
- Models APX525, APX625, APX725 and APX825 - the control retries 1 time and then goes into hard lockout. Manual reset is required to resume boiler operation.

8. Central Heating System Frost Protection

When enabled, Frost Protection starts the boiler and system pump and fires the boiler when low outside air and low supply water temperatures are sensed. The Control provides the following control action when frost protection is enabled:

Table 26: Frost Protection

Device Started	Start Temperatures	Stop Temperatures
Boiler & System Pump	Outside Air < -22°F (-30°C) Supply Water < 45°F (7.2°C)	Outside Air > -18°F (-28°C) Supply Water > 50°F (10°C)
Boiler	Supply Water < 38°F (3.3°C)	Supply Water > 50°F (10°C)

FROST PROTECTION NOTE

The Control helps provide freeze protection for the boiler water. Boiler flue gas condensate drain is not protected from freezing. Since the Control only controls the system and boiler circulators individual zones are not protected. It is recommended that the boiler be installed in a location that is not exposed to freezing temperatures.

X. Operation D. Multiple Boiler Control Sequencer (continued)

D. Multiple Boiler Control Sequencer

1. “Plug & Play” Multiple Boiler Control Sequencer

When multiple boilers are installed, the Control’s Sequencer may be used to coordinate and optimize the operation of up to eight (8) boilers. Boilers are connected into a “network” by simply “plugging in” standard ethernet cables into each boiler’s “Boiler-To-Boiler Communication” RJ45 connection.

2. Sequencer Master

A single Control is parameter selected to be the Sequencer Master. The call for heat, outdoor and header sensors, and common pumps are wired to the Sequencer Master “enabled” Control.

3. Lead/Slave Sequencing & Equalized Run Time

One boiler is a “Lead” boiler and the remaining networked boilers are “Slaves”. When demand is increasing, the Lead boiler is the first to start and the Slave boilers are started in sequential order (1,2,3,...) until the demand is satisfied. When demand is decreasing, the boilers are stopped in reverse order with the Lead boiler stopped last (...3,2,1). To equalize the run time the sequencer automatically rotates the Lead boiler after 24 hours of run time.

4. Improved Availability

The following features help improve the heat availability:

- a. Backup Header Sensor: In the event of a header sensor failure the lead boiler’s supply sensor is used by the Sequence Master to control firing rate. This feature allows continued coordinated sequencer control even after a header sensor failure.
- b. “Stand Alone” Operation Upon Sequence Master Failure: If the Sequence Master Control is powered down or disabled or if communication is lost between boilers, individual boilers may be setup to automatically resume control as a “stand alone” boiler.
- c. Slave Boiler Rate Adjustment: Each slave boiler continues to monitor supply, return and flue gas temperatures and modifies the Sequence Master’s firing rate demand to help avoid individual boiler faults, minimize boiler cycling and provide heat to the building efficiently.
- d. Slave Boiler Status Monitoring: The Sequence Master monitors slave boiler lockout status and automatically skip over disabled boilers when starting a new slave boiler.

5. Customized Sequences

Normally, boilers are started and stopped in numerical order. However, custom sequences may be established to optimize the heat delivery. For example, in order to minimize boiler cycling, a large boiler may be selected to run first during winter months and then selected to run last for the remainder of the year.

6. Multiple Demands

The Sequence Master responds to Central Heat, Auxiliary Heat DHW and frost protection demands similar to the stand alone boiler. For example, when selected and DHW priority is active, the sequence master uses DHW setpoint, “Diff Above”, “Diff Below” and pump settings.

7. Shared or Isolated DHW Demand

When the Indirect Water Heater (IWH) parameter is set to “Primary Piped” the Sequence Master sequences all required boilers to satisfy the DHW setpoint (default 180°F (82.2°C)). When “Boiler Piped” is selected only the individual slave boiler, with the wired DHW demand and pump, fires to satisfy the DHW setpoint.

8. DHW Two boiler Start

When the Indirect Water Heater (IWH) parameter is set to “Primary Piped” and the DHW Two Boiler Start parameter is set to “Enabled” two boilers are started without delay in response to a DHW call for heat. This feature allows rapid recovery of large IWH’s and multiple IWH’s.

9. Optimized Boiler Modulation

Boiler firing rate is managed to increase smoothly as boilers are started. For example, when a second boiler is started the initial firing rate is 100%/2 or 50%, when the third boiler is started the firing rate starts at 200%/3 or 66%. After the initial start, the Sequence Master develops a unison firing rate demand based on it’s setpoint and sensed header temperature.

10. Modulating Condensing Boiler Control

During low loads, the Sequence Master limits firing rates to a ‘Base Load Common Rate’ to ensure peak modulating condensing boiler operating efficiency. Lower firing rates boost efficiency by helping increase the amount of flue gas water vapor condensation. The Control maintains a “Base Load Common Rate” until the last lag boiler is started. At this point, the “Base Load Common Rate” is released to allow boilers to modulated as required to meet heat load.

11. Advanced Boiler Sequencing

After there is a Call For Heat input, both header water temperature and boiler firing rate percent are used to start and stop the networked boilers. The control starts and stops boilers when the water temperature is outside the user selected “Diff Above” and “Diff Below” settings. Also, in order to minimize temperature deviations, the control adjusts the number of boilers running based on the firing rate. This combination allows the boilers to anticipate slow load changes before they disrupt water temperature yet still respond quickly to sudden load changes. These special sequencer features help reduce energy wasting system temperature swings and the resulting unnecessary boiler cycling.

12. Stop All Boilers

All boilers are stopped without delay if the Call for Heat input is removed, or, if the header temperature is higher than 195°F (90.6°C) (field adjustable).

X. Operation E. Boiler Sequence Of Operation (continued)

E. Boiler Sequence of Operation

1. Normal Operation

Table 27: Boiler Sequence of Operation

Status Screen Display	Description
	<p>(burner Off, circulator(s) Off)</p> <p>Boiler is not firing and there is no call for heat, priority equals standby. The boiler is ready to respond to a call for heat.</p>
	<p>(burner Off, circulator(s) On)</p> <p>Boiler is not firing. There is a Central Heat call for heat and the Supply temperature is greater than setpoint minus the "Diff Below".</p>
	<p>When supply temperature drops burner demand continues with following Status shown:</p> <p>Safe Startup: Flame circuit is tested. Drive purge: The blower is driven to the fan purge speed. Prepurge: After the blower reaches the fan purge speed setting the 10 second combustion chamber purge is conducted.</p>
	<p>After purge time is complete the following Status is shown:</p> <p>Drive light-off: The blower is driven to light-off rate. Pre-Ignition Test: After the blower reaches light-off rate a safety relay test is conducted. Pre-ignition: Spark is energized and it is confirmed that no flame is present Direct Ignition: Spark and Main fuel valve are energized.</p>
	<p>(burner On, circulator(s) On)</p> <p>After flame is proven the sequence continues with run stabilization and low fire hold time. Once the field adjustable low fire hold time is completed normal boiler operation begins, modulation rate depending on temperature and setpoint selections.</p>
	<p>If the Central Heat call for heat is active and a Domestic Hot Water (DHW) call for heat received the DHW demand becomes the "priority" and the modulation rate, setpoint, "Diff Above" and "Diff Below" are based on DHW settings.</p>
	<p>(burner Off, circulator(s) Off)</p> <p>If there is no call for heat, the main fuel valve is closed and, the blower is driven to the fan post-purge speed. After the blower reaches the fan post-purge speed setting, the 30-second combustion chamber purge is conducted.</p>
	<p>Standby delay status is entered when a delay is needed, before allowing the burner control to be available. For example, when Anti-Short Cycle time is selected Standby delay is entered after the Central Heat call for heat ends. Select "Help" button from the "Home Screen" to determine the cause of the Standby Delay.</p>
	<p>A lockout Status is entered to prevent the boiler from running due to a detected problem. Select "Help" button from the "Home Screen" to determine the cause of the Lockout. The last 10 Lockouts are recorded in the Lockout History.</p>

X. Operation E. Boiler Sequence Of Operation (continued)

2. Using The Display

The Control includes a touch screen LCD display. The user monitors and adjusts boiler operation by selecting screen navigation “buttons” and symbols. The “Home Screen” and menu selections are shown below. When no selection is made, while viewing any screen, the display reverts to the “Home Screen” after 4 minutes. The “Home Screen” provides boiler temperature, firing rate in BTU/hr, boiler status, efficiency information and page links.

Menu Buttons

The Home Screen Menu Buttons connect the displays four main display groups:

Information Symbol

“Information” symbol links most screens to screen content explanations. New terminology used in status and adjustment screens are explained in plain words.

Fault Indication

In the event of a boiler fault the screen color turns red and the user is guided by “blinking” touch buttons to Help screens that explain the problem cause and corrective action.

Rate

Firing rate is displayed as kbtu/hr input.

Demand Status

The reason or cause of the boiler demand is displayed; Central Heat, Auxiliary Heat, Domestic Hot Water, Sequencer Control (peer-to-peer Demand) or Frost Protection. Warm Weather Shutdown status is shown. “Standby” is shown when no demand is present.

Energy Save On Indication

Outdoor Air Reset, DHW or setback have lowered boiler water setpoint.

High Efficiency On Indication

Return temperature is low enough to allow energy saving flue gas condensation.

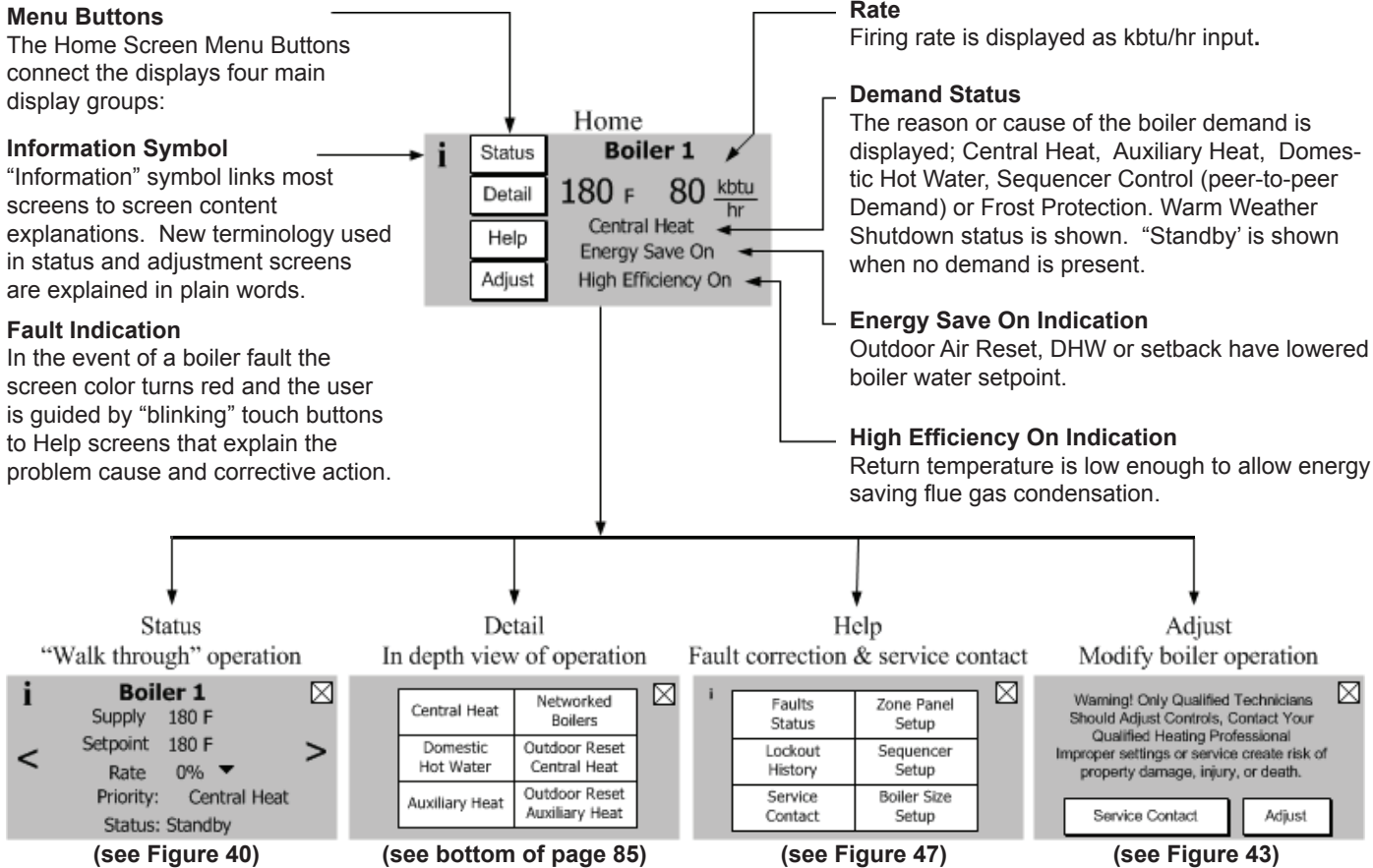

Figure 37: Home Screen Details

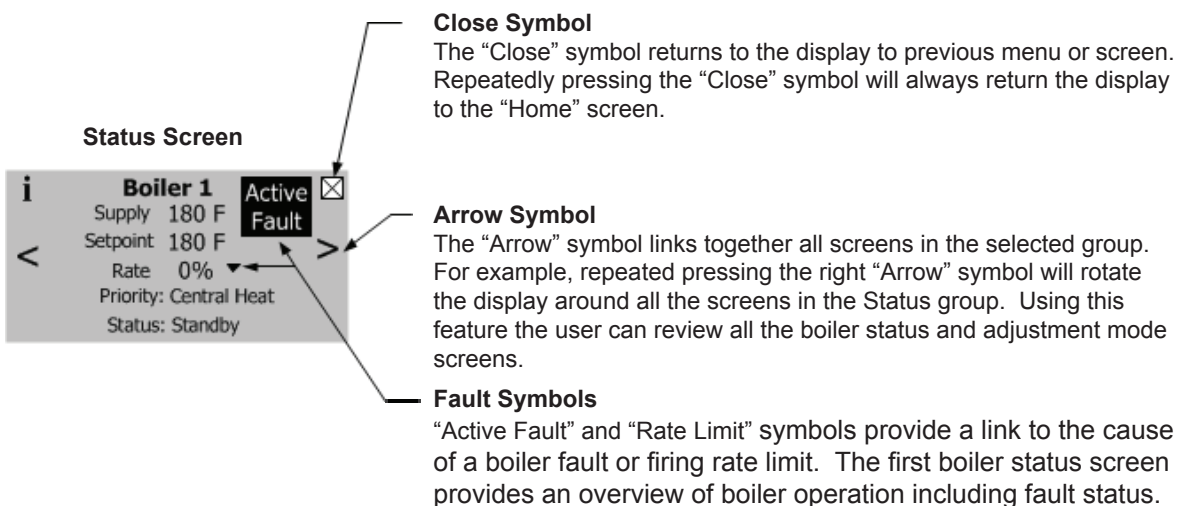

Figure 38: Screen Navigation

X. Operation E. Boiler Sequence Of Operation (continued)

3. Status Screens

Boiler Status screens are the primary boiler monitoring screens. The user may simply “walk” through boiler operation by repeatedly selecting the right or left “arrow” symbol. These screens are accessed by selected the “Status” button from the “Home” screen.

NOTE

Only visible if Zone Panel is connected. Zone Panel 1 and 2 shown typical for 1 through 4.

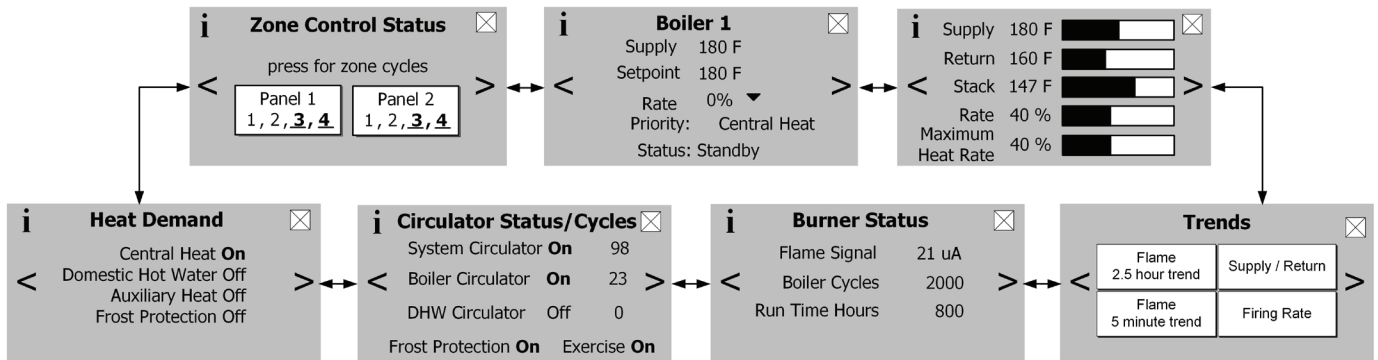

Figure 39: Status Screen Overview

Supply:

Measured supply water temperature. This is the temperature being used to start/stop and fire boiler when there is a call-for-heat. Header temperature is shown when selected.

Setpoint:

This is the active setpoint. This temperature setpoint determined based on active priority; Central Heat, Auxiliary Heat or Domestic Hot Water. The setpoint may be the result of Outdoor Air Reset and Setback selections.

Rate:

The rate % value is equal to the actual kbtu/hr input divided by the boiler rated input.

Priority:

The selected Priority is shown. Available Priorities are: Standby (no call for heat is present), Sequencer Control, Central Heat, Auxiliary Heat, Domestic Hot Water, Frost Protection or Warm Weather Shutdown.

Active fault:

A hard lockout will cause the active fault indication to appear. When visible the text becomes a screen link to the “Help” Menu.

Rate Limit:

The “▼” symbol appears to the right of the Rate % when firing rate is limited or overridden in any way. During the start-up and shutdown sequence it is normal for the rate to be overridden by the purge, light-off and low fire hold requirements. When a rate limit is the result of boiler protection logic the “▼” symbol blinks and becomes a screen link.

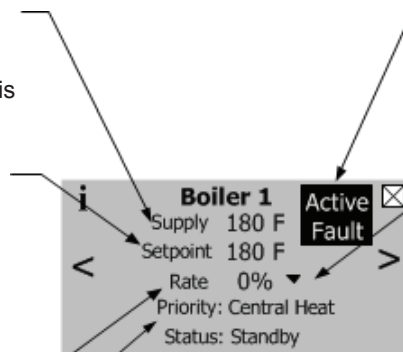

Status:

Information found at the bottom of the Status screen and on the Home screen. Table 27 shows each status and the action the control takes during the condition.

Figure 40: Boiler Status Screen Definitions

X. Operation E. Boiler Sequence Of Operation (continued)

3. Status Screens (continued)

Bargraph Screen

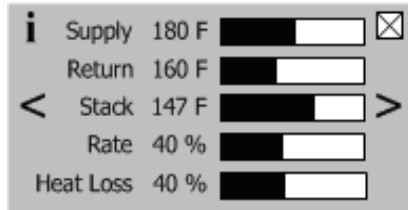

Bargraph Screen

The bargraph screen presents measured values for easy comparison. Included on this screen is firing rate and when the Zone Panel is connected the measure Heat Loss. Measured heat loss is the heat rate kbtu/hr sum of all active (call for heat) zones. This value represents the maximum required firing rate.

Trend Screens

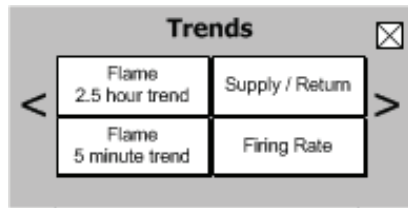

Data Logging

Real time graphic trends allow users to observe process changes over time providing valuable diagnostic information. For example, flame current performance over start up periods and varying loads can be an indication of gas supply issues. Additionally, supply and return temperature dual pen trends brings a focused look at heat exchanger and pump performance. For example, studying a differential temperature trend may indicate pump speed settings need to be changed.

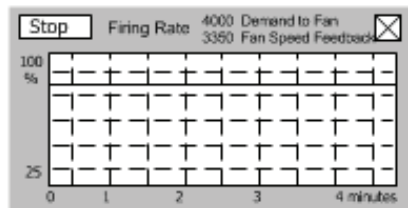
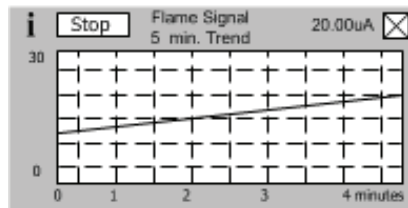
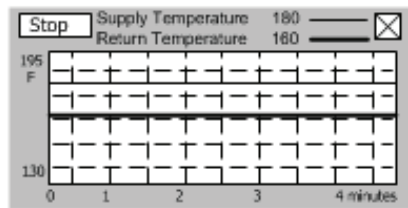
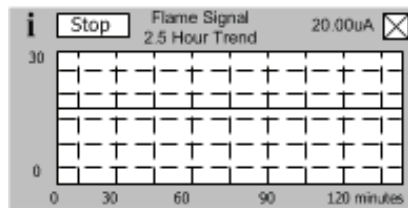

NOTE

Firing Rate Trend shows fan demand and feedback.

Burner Status Screen

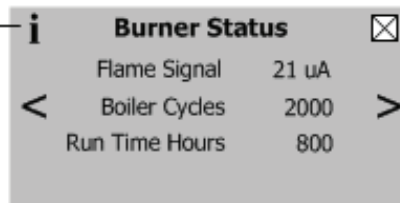
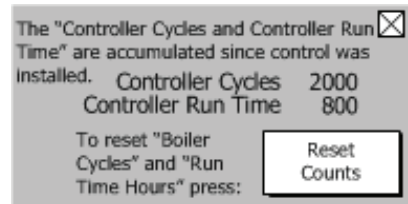

Cycles and Hours

Boiler cycles and hours are used to monitor the boilers overall compatibility to the heating load. Excessive cycling compared to run time house may be an indication of pumping, boiler sizing or adjustment issues.

NOTE

“Boiler Cycle” and “Run Time Hours” are resettable by selecting the “Reset Counts” button located on the information screen. The “Controller Cycles” and “Controller Run Time” data is not resettable and remains for the life of the control.

X. Operation E. Boiler Sequence Of Operation (continued)

Circulator Status Screen

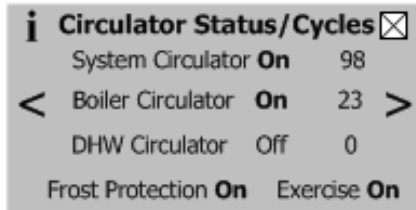

Pumping is a major part of any hydronic system. This screen provides the status of the boiler's demand to connected pumps as well as the status of Frost Protection and pump Exercise functions.

Head Demand Screen

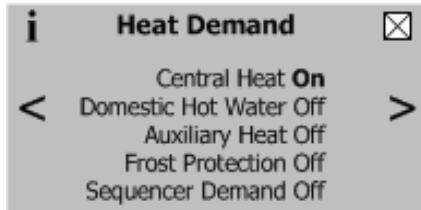

This screen provides the status of the boiler's five (5) possible heat demands. When demand is off the Control has not detected the call-for-heat. This screen allows the user to determine which demands are present when more than one demand is present.

Zone Control Status Screens

NOTE

Only visible if Zone Panel is connected. Zone Panel 1 and 2 shown typical for 1 through 4.

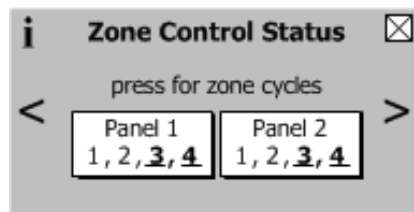

Zone Control Status

Screen provides status and a page links for up to four zone panels. Individual zone "on" status is shown by a bold zone number with a solid underscore. "Press" the zone control "button" to view individual zone.

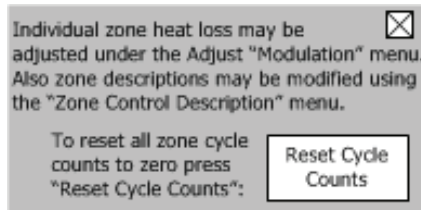

NOTE

Zone cycles are resettable by selecting the "Reset Cycle Counts" button located on the information screen.

Demand	Cycles	Size (kbtu/hr)
KITCHEN	OFF 500	15
KIDS BEDROOM	OFF 100	23
MASTER BEDROOM	ON 50	28
Domestic HW	ON 3500	40

Zone Panel 1 (typical for 2 through 4)

Zone panel screens show individual zone status, cycle counts and individual zone heat loss size in kbtu/hr. Individual zone heat loss may be adjusted under the Adjust "Modulation" menu. Also zone descriptions may be modified using the "Zone Control Description Setup" menu.

4. Detail Screens

Detail screens are accessed by selecting the "Detail" button from the "Home" screen. These screens provide in depth operating parameter status such as "On Point", "Off Point" and "Setpoint Source" information. Demand-specific details are provided for Central Heat, Auxiliary Heat, Domestic Hot Water and the Sequence Master demands. Detail screens also provide details on outdoor air reset and Sequencer network status. Sequencer screens are only shown when the Sequence Master is enabled and, Auxiliary Heat screen is only shown when a Zone Panel is connected.

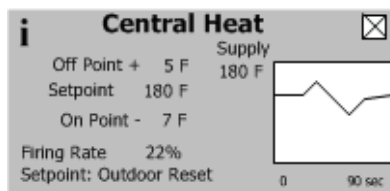

Demand Detail Display
(Central Heat shown, Typical for Auxiliary Heat, Domestic Hot Water and Sequencer Master)

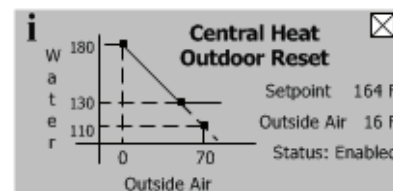

Outdoor Reset Display
(Central Heat shown, Typical for Auxiliary Heat)

X. Operation E. Boiler Sequence Of Operation (continued)

5. Multiple Boiler Sequencer Screens

When the Sequence Master is enabled the following screens are **available**:

The Sequencer Status screen is selected by “pressing” “Status” button from the “Home” screen when Sequence Master is enabled.

Header:

measured header water temperature. This is the temperature being used to start, stop and fire boiler when there is a call-for-heat.

Setpoint:

this is the active setpoint. This temperature is the result of Outdoor Air Reset, Setback and Domestic Hot Water (DHW) selections.

Networked Boiler Status:

Provides connected, start sequence and firing rate status information for all connected boiler addresses. The boiler number is underlined if the boiler is running and blinks if the boiler has the start sequence in progress. For example the status for boiler address 1 is provided as follows:

- 1 - Boiler 1 is connected to the network
- 1 - “Blinking underline” - boiler 1 is starting
- 1 - “Solid underline” - boiler 1 is running

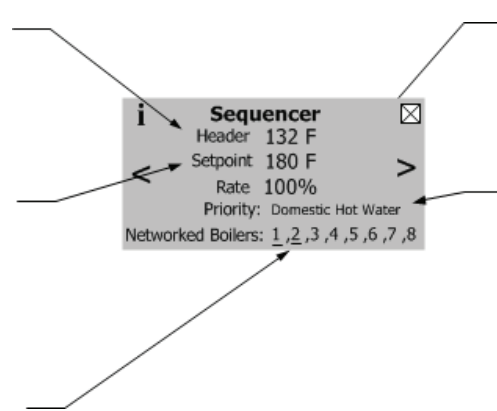

Rate:

The rate % value is equal to the Sequence Master demand to the individual boiler. Actual boiler firing rate is found on the individual boiler status pages.

Priority:

The selected Sequencer Priority is shown. Available Priorities are: Standby (no call for heat is present), Central Heat, Auxiliary Heat, Domestic Hot Water, Frost Protection or Warm Weather Shutdown.

The “Networked Boilers” screen is selected by “pressing” the “Detail” button from the “Home” screens and “pressing” Networked Boilers” from the “Detail” screen.

Boiler Number:

Up to eight (8) boiler’s status is shown

Lead Boiler:

Upon power up the lowest numbered boiler becomes the lead boiler. The lead boiler is the first to start and last to stop. The lead boiler is automatically rotated after 24 hours of run time. Additionally, the lead is rotated if there is a lead boiler fault.

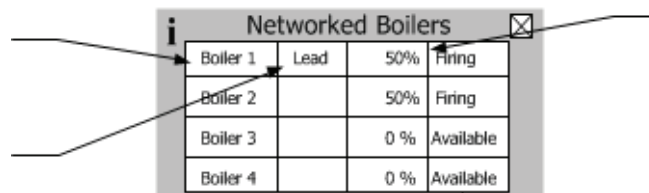

Firing Rate:

Demanded firing rate is provided.

Sequence Status:

Slave boiler status is provide as follows:

- Available:** Boiler is ready and waiting to be started by the Sequencer Master.
- Add Stage:** Master.
- Running:** Boiler has begun the start sequence but has not yet reached the boiler running status.
Boiler is running.
- On Leave:** Boiler has left the network to service a DHW demand.
- Recovering:** Boiler is in the process of returning to the network. For example, the slave boiler is in the Postpurge state.
Note: The recovery time is normally 30 seconds. However, if the slave boiler fails to start the recovery time increases from 30 seconds to 5, 10 and 15 minutes.
- Disabled:** Boiler has a lockout condition and is unable to become available to the Sequencer Master.

X. Operation F. Changing Adjustable Parameters (continued)

F. Changing Adjustable Parameters

1. Entering Adjust Mode

The Control is factory programmed to include basic modulating boiler functionality. These settings are password protected to discourage unauthorized or accidental changes to settings. User login is required to view or adjust these settings:

- Press the “Adjust” button on the “Home” screen.
- Press the “Adjust” button on the Adjust Mode screen or Press “Service Contact” for service provider contact information.
- Press “Login” button to access password screen.
- Press 5-digit display to open a keypad. Enter the password (Installer Password is 86) and press the return arrow to close the keypad. Press the “Save” button.
- Press the “Adjust” button to enter Adjustment mode.

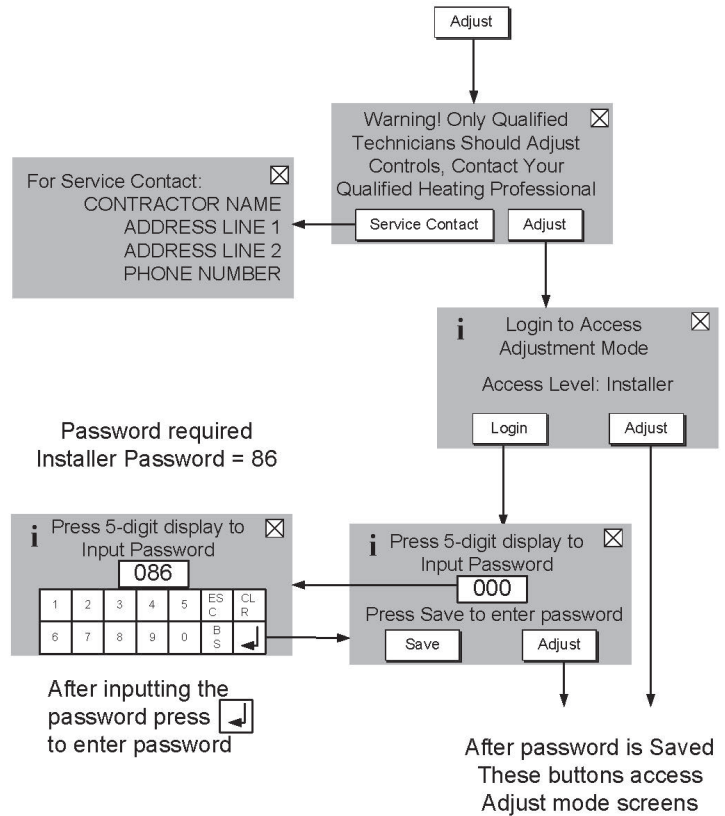
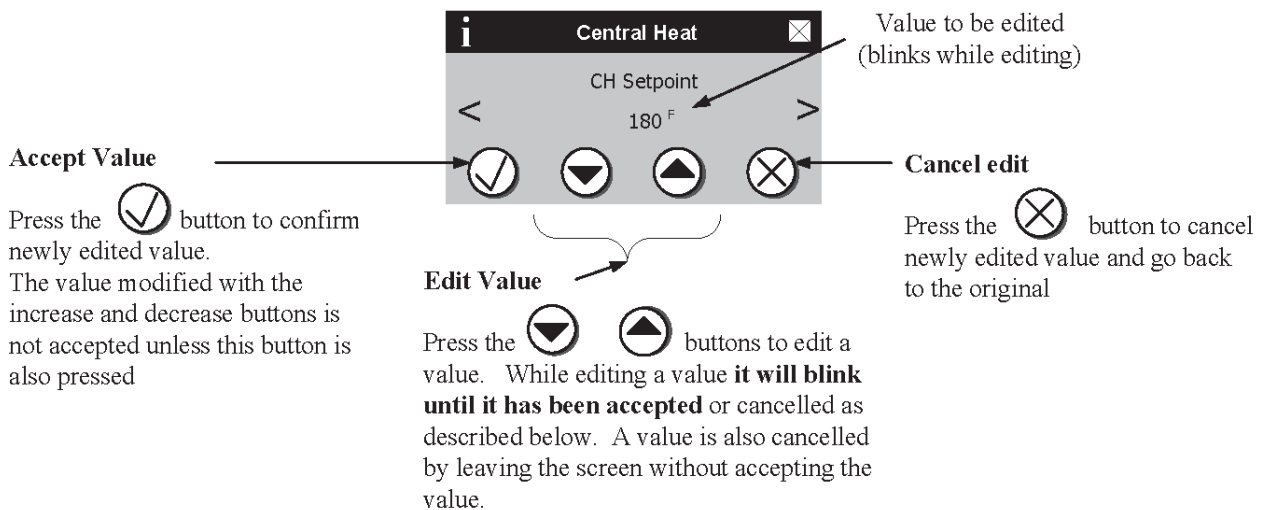

Figure 41: Adjust Mode Screens

2. Adjusting Parameters

Editing parameters is accomplished as follows:



X. Operation F. Changing Adjustable Parameters (continued)

2. Adjusting Parameters (continued)

The following pages describe the Control’s adjustable parameters. Parameters are presented in the order they appear on the Control’s Display, from top to bottom and, left to right. From the “Home” screen select the Adjust button to access the adjustment mode screens show below (if required, refer to the previous page to review how to enter Adjustment mode):

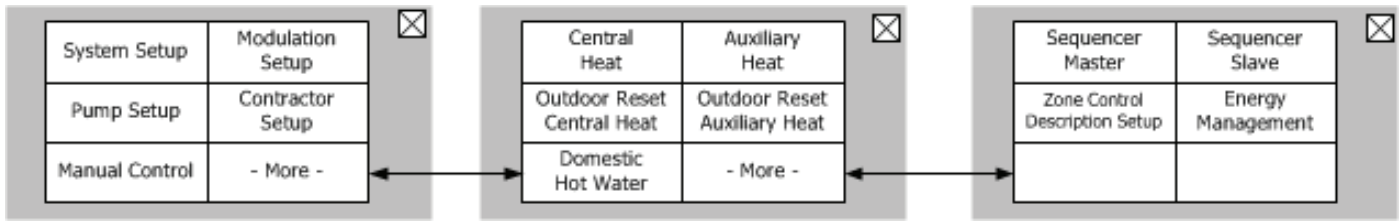

“Press” System Setup button to access the following parameters:

Factory Setting	Range / Choices	Parameter and Description						
Fahrenheit	Fahrenheit, Celsius	Temperature Units The Temperature Units parameter determines whether temperature is represented in units of Fahrenheit or Celsius degrees.						
4	0-14	Display Brightness Display brightness is adjustable from 0 to 14.						
8	0-14	Display Contrast Display contrast is adjustable from 0 to 14.						
Wired	Not Installed, Wired, Wireless	Outdoor Sensor Source Not Installed Outdoor Sensor is not connected to the boiler, the sensor is not monitored for faults. Wired Outdoor Sensor is installed directly on the boiler terminal Strip-TB2. Wireless Outdoor sensor is installed and wireless.						
0	-100 to 100 tenths of degree	Outdoor Air Sensor Calibration Outdoor Air Sensor Calibration offset allows a single point calibration. Using a reliable source (reference) for outdoor temperature measure outdoor air temperature. Set the offset equal to the difference between the controller reading and the reference. The result will be the Control's measurement matching the reference reading.						
Not Connected	Connected, Not Connected	Zone Control Status Connected When the Zone Control is connected adjustable settings are automatically shown under the Adjust “Modulation”, “Auxiliary Heat” and “Zone Control Description Setup” menus. This feature allows these adjustments to be made before the zone panel is connected. When the user selects “Show As If Connected” Zone Control related parameters are made visible and may be adjusted.						
Enabled	Enable/Disable	Frost Protection Disable Frost Protection is not used. Enable Boiler and system circulators start and boiler fires when low outside air, supply and return temperatures are sensed as follows: <table style="width: 100%; border: none;"> <tr> <td style="text-align: center;">Device Started</td> <td style="text-align: center;">Start Temperatures</td> <td style="text-align: center;">Stop Temperatures</td> </tr> <tr> <td style="text-align: center;">Boiler & System</td> <td style="text-align: center;">Outside Air < -22°F (-30°C)</td> <td style="text-align: center;">Outside Air > -18°F (-28°C)</td> </tr> </table>	Device Started	Start Temperatures	Stop Temperatures	Boiler & System	Outside Air < -22°F (-30°C)	Outside Air > -18°F (-28°C)
Device Started	Start Temperatures	Stop Temperatures						
Boiler & System	Outside Air < -22°F (-30°C)	Outside Air > -18°F (-28°C)						
0 Secs	0-900 Secs	Anti-Short Cycle Time Anti-short cycle is a tool that helps prevent excessive cy-cling resulting from a fast cycling Thermostat or Zone valves. It provides a minimum delay time before the next burner cycle. DHW demand is serviced immediately, without any delay.						
Disabled	Enable/Disable	Warm Weather Shutdown Enable Disable Warm Weather Shutdown (WWSD) is not used. Enable The boiler and pumps will not be allowed to start in response to a central heat call for heat if the outside temperature is greater than the WWSD setpoint. WWSD is initiated as soon as outside air temperature is above WWSD Setpoint. The control does not require call for heat to be satisfied. The boiler will still start in response to a Domestic Hot Water call for heat.						
70°F	0-100°F	Warm Weather Shutdown Setpoint The Warm Weather Shutdown (WWSD) Setpoint used to shutdown the boiler when enabled by the “WWSD Enable” parameter.						

X. Operation F. Changing Adjustable Parameters (continued)

2. Adjusting Parameters (continued)



WARNING

Asphyxiation Hazard. Boiler type is factory set and must match the boiler model. Only change the boiler type setting if you are installing a new or replacement Control. The boiler type setting determines minimum and maximum blower speeds. Incorrect boiler type can cause hazardous burner conditions and improper operation that may result in PROPERTY LOSS, PHYSICAL INJURY OR DEATH.

“Press” Modulation Setup button to access the following parameters:

Factory Setting	Range / Choices	Parameter and Description
See Table 28	See Table 28	<p>Boiler Type Boiler Size Setup To verify the boiler size selection, a qualified technician should do the following:</p> <ol style="list-style-type: none"> 1. Check boiler’s label for actual boiler size. 2. Set “Boiler Type” to match actual boiler size. 3. Select “Confirm”. <p>The Boiler Type parameter changes the minimum and maximum modulation settings. This parameter is intended to allow a user to set the parameters in a spare part Control to a particular boiler type.</p>

Table 28: Parameters Changed Using the Boiler Type Parameter Selections:

R7910 Control Repair Kit	106192-01	106192-02	106192-03	106192-04	106192-03	106192-04	106192-02	
Altitude	0 - 4500 ft.		0 - 2000 ft.				0 - 4500 ft.	
Boiler Type	425 -07	525 -07	625N -02	625P -02	725N -02	725P -02	825N -05	825P -05
Maximum Light-off Rate (RPM)	4000	4000	2500	4000	2500	4000	4000	4000
Maximum Modulation Rate (RPM)	7600	5900	5050	4800	4350	4400	5200	5150
Minimum Modulation Rate (RPM)	2100	1400	1600	1600	1400	1450	1200	1200
Absolute Maximum Modulation Rate (RPM)	8500	6550	5900	6300	5500	5850	5900	5600

NOTE: Maximum Modulation Rates are designed for 100% nameplate rate at 0°F (-18°C) combustion air. Contact factory before attempting to increase the Maximum Modulation Rate.

X. Operation F. Changing Adjustable Parameters (continued)

Expected Heat Rate Adjustment Screens (HeatMatch Software)

The Control is shipped with defaults that will provide improved operation. Adjustment is only required to optimize setup.

The expected heat rate adjustment is used to better match boiler output to the home heating needs. After receiving a "call for heat" the Control first uses the expected heat rate value to set a maximum heat rate. The maximum heat rate is the highest heat rate that the boiler can fire to at that moment. The maximum heat rate is the summation of the expected heat rates for the active (turned on) zones. After establishing the maximum heat rate the Control then measures water temperature and fires the boiler only as hard as required for the heat demand.

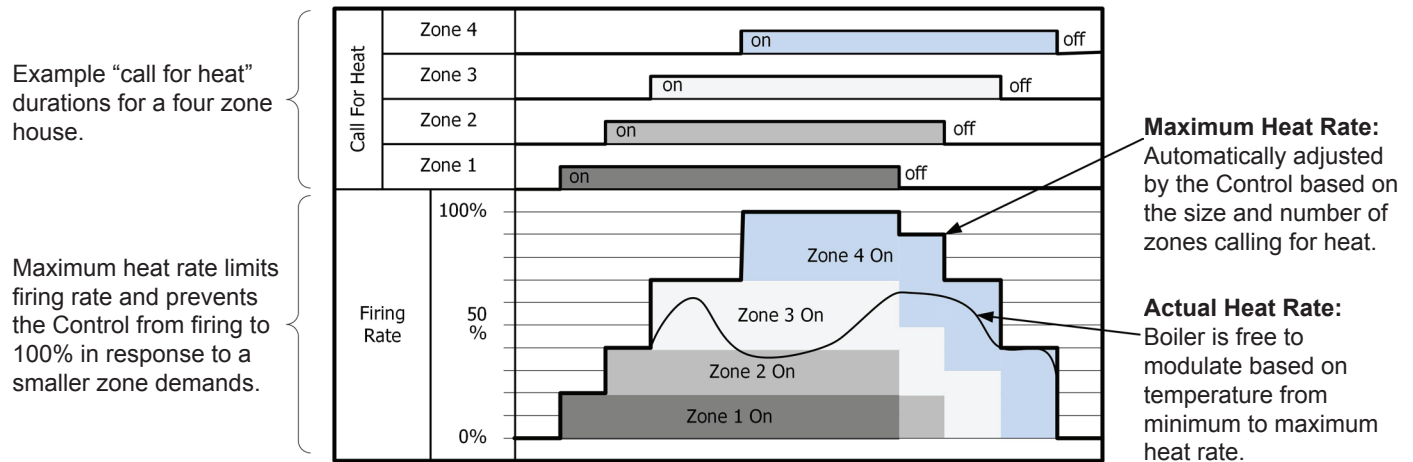
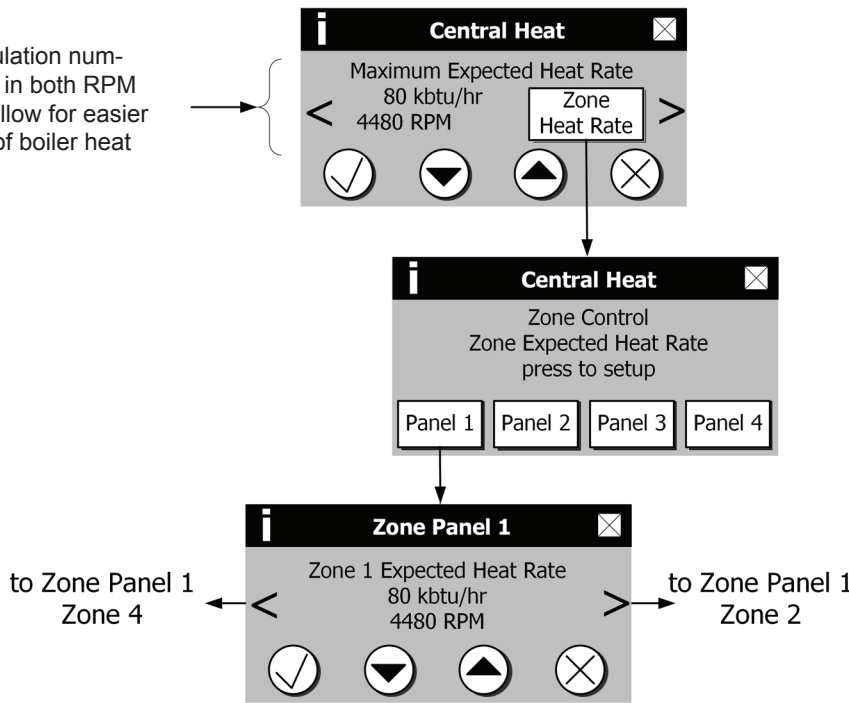

Figure 42: Four Zone House (with Zone Control Connected)

Maximum modulation numbers are shown in both RPM and kbtu/hr to allow for easier understanding of boiler heat rate.



NOTE

This feature requires Zone Control to be connected. Refer to Electrical section for Zone Control connection information.

The sum of Zone Expected Heat Rates plus DHW Maximum Expected Heat Rate (if DHW is active) is used to calculate the active maximum modulation rate.

Zone Panel 1, Zone 1 shown, (Typical for zones 1 through 16)

Figure 43: Expected Heat Rate Adjustment (with Zone Control Connected)

X. Operation F. Changing Adjustable Parameters (continued)

“Press” Modulation Setup button to access the following parameters:

Factory Setting	Range / Choices	Parameter and Description
100%	Minimum to Maximum Heat Rate	<p>Central Heat Maximum Expected Heat Rate This parameter defines the highest modulation rate the Control will go to during a central heat call for heat. If the rated input of the installed home radiation is less than the maximum output of the boiler, change the Central Heat Maximum Expected Heat Rate (fan speed) setting to limit the boiler output accordingly.</p>
80%	Minimum to Maximum Heat Rate	<p>Domestic Hot Water (DHW) Maximum Expected Heat Rate This parameter defines the highest modulation rate the Control will go to during a Domestic Hot Water call for heat. If the rated input of the indirect water heater is less than the maximum output of the boiler, change the DHW Maximum Expected Heat Rate (fan speed) setting to limit the boiler output accordingly.</p>
100%	Minimum to Maximum Heat Rate	<p>Auxiliary Maximum Expected Heat Rate This parameter defines the highest modulation rate the Control will go to during the auxiliary heat call for heat. If the rated input of the Auxiliary Heat Zones is less than the maximum output of the boiler, change the Auxiliary Heat Maximum Expected Heat Rate (fan speed) setting to limit the boiler output accordingly.</p>
40%	Minimum to Maximum Heat Rate	<p>Zone 1 Expected Heat Rate (typical for zone 1 through 16) This parameter defines the highest modulation rate the Control will go to during the Zone 1 call for heat. If the rated input of the installed home radiation in zone 1 is less than the maximum output of the boiler, change the Zone 1 Expected Heat Rate (fan speed) setting to limit the boiler output accordingly.</p>
30 Minutes	0 to 60 Minutes	<p>Zone Release Time After the Zone Release Time minutes and a zone has not been satisfied (thermostat opens) the measured heat loss will be released to increase to the Central Heat Maximum Heat Rate.</p>
See Table 28	Minimum - 100 to Maximum	<p>Minimum Heat Rate This parameter is the lowest modulation rate the Control will go to during any call for heat.</p>
See Table 28	See Table 28	<p>Lightoff Heat Rate This is the blower speed during ignition and flame stabilization periods.</p>

X. Operation F Changing Adjustable Parameters (continued)

“Press” Pump Setup button to access the following parameters:

Factory Setting	Range / Choices	Parameter and Description
Any Demand	Never, Any Demand, Central Heat, No Priority, Central Heat, Optional Priority	System Pump run pump for: Activates the system pump output according to selected function. Never: Pump is disabled and not shown on status screen. Any Demand: Pump Runs during any call for heat. Central Heat, No Priority: Pump Runs during central heat and frost protection call for heat. Pump <u>does not start</u> for a DHW call for heat and continues to run during Domestic Hot Water Priority. Central heat, Optional Priority: Pump Runs during central heat and frost protection call for heat. Pump <u>does not start</u> for a DHW call for heat and will be forced off if there is a DHW call for heat and Domestic Hot Water Priority is active.
Any Demand	Any Demand, Central Heat, off DHW demand	Boiler Pump run pump for: Activates the boiler pump output according to selected function. Any Demand: Pump Runs during any call for heat. Central Heat, off DHW demand: <u>Make sure indirect water heater and DHW circulator are sized to maintain flow through boiler within limits shown in Table 12.</u> Pump Runs during central heat and frost protection call for heat. Pump does not start for a DHW call for heat and will be forced off if there is a DHW call for heat and Domestic Hot Water Priority is active.
Primary Loop Pipe IWH	Never, Primary Loop Piped IWH, Boiler Piped IWH	Domestic Pump run pump for: Activates the Domestic pump output according to selected function. Never: Pump is disabled and not shown on status screen. Primary Loop Piped IWH: Pump Runs during domestic hot water call for heat. Domestic Hot Water Priority enable/disable does not affect pump operation. Boiler Piped IWH: <u>Make sure indirect water heater and DHW circulator are sized to maintain flow through boiler within limits shown in Table 12.</u> Pump Runs during domestic hot water call for heat. Pump is forced off during a central heat call for heat when Domestic Hot Water Priority “disabled” is selected and when Domestic Hot Water Priority “enable” has been selected and the DHW call for heat has remained on for longer than 1 hour (priority protection time).

Example Pump Parameter selections:

Single boiler with no Indirect Water Heater

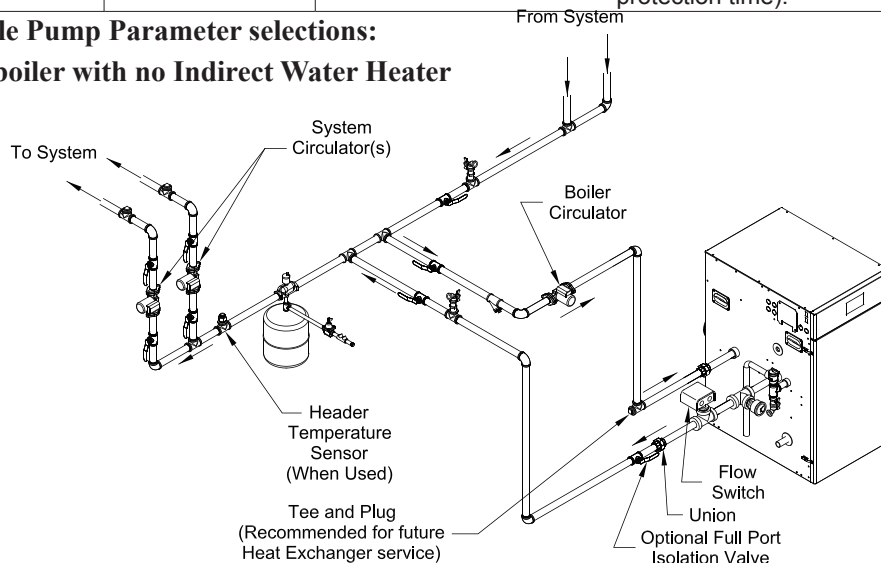

Parameter Selections:

System Pump= “any demand”
 Boiler Pump = “any demand”
 DHW Pump = “never”

Explanation:

This piping arrangement only services central heat. When there is any demand both boiler and system pumps turn on.

X. Operation G. Changing Adjustable Parameters (continued)

Example Pump Parameter selections (continued):

Single boiler Indirect Water Heater Piped to Primary, Optional Domestic Hot Water Priority.

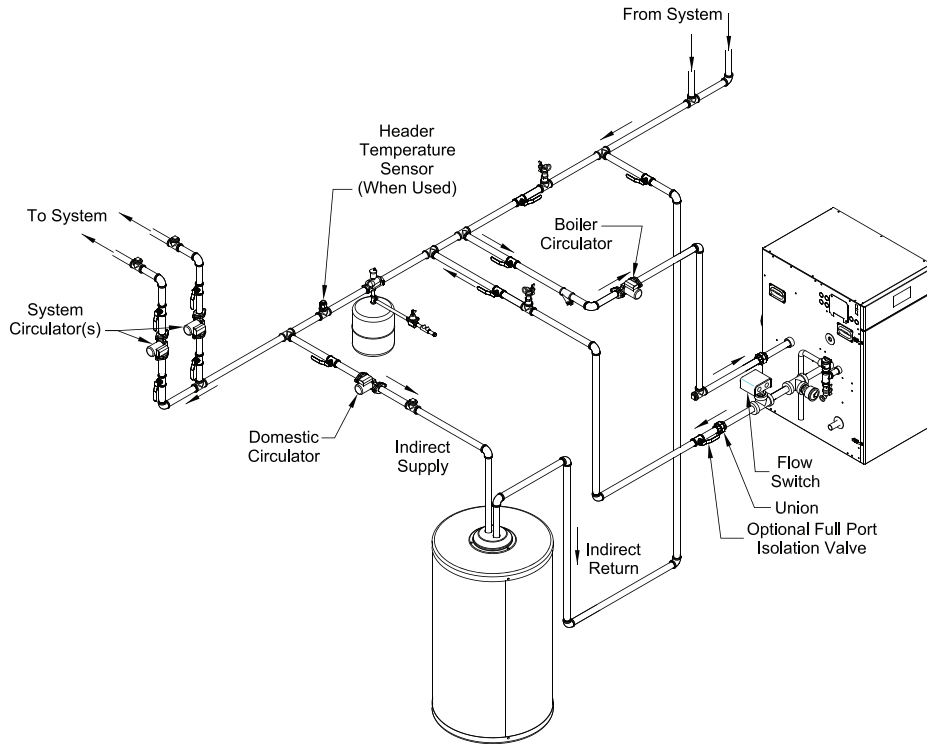

Parameter Selections:

System Pump = "Central Heat ,
Optional Priority"

Boiler Pump = "any demand"

DHW Pump = "Primary Loop Piped IWH"

DHW Priority Enable is optional

Explanation:

This piping arrangement permits the system pump to run or not run when there is a domestic hot water call for heat. Domestic hot water priority is optional. It is permissible for the domestic and system pumps to run at the same time. The boiler pump must run for every call for heat.

Multiple Boilers with Boiler Piped IWH, System and DHW Wired to Master

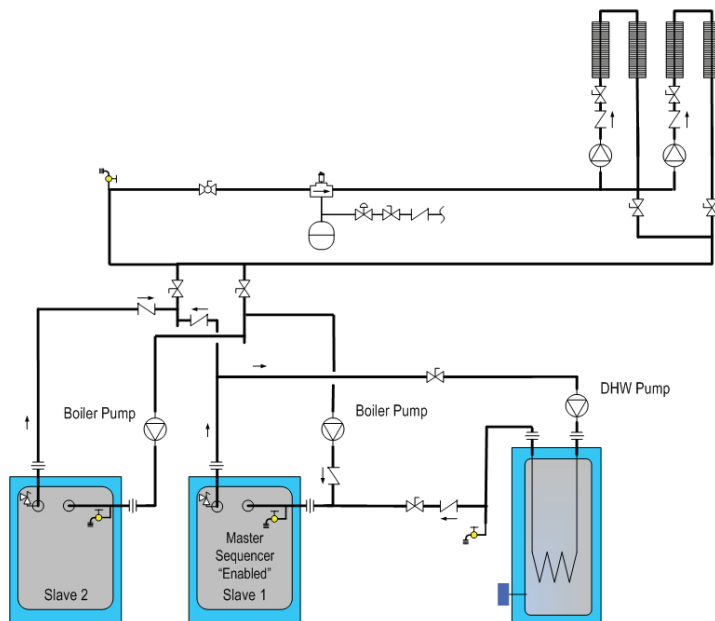

	Sequencer Master (Boiler 1)	Boiler 2
Wiring locations:		
Thermostat	X	
DHW call for heat	X	
System pump	X	
DHW pump	X	
Boiler Pump	X	X
Sequencer Master Parameter Selections:		
Sequencer Master	Enabled	
Indirect Water Heater	"Boiler Piped"	
Pump Parameter Selections:		
System Pump =	Central Heat, No Priority	Never
Boiler Pump =	Central Heat, Off DHW Priority	Any demand
DHW Pump =	Boiler Piped IWH	Never

Explanation:

Make sure indirect water heater and DHW pump are sized to maintain flow through boiler within limits shown in Table 12.

This piping arrangement does not allow both the Slave 1's boiler and domestic hot water pump to run at the same time.

When call for Domestic Hot Water is received the DHW pump is turned on and the boiler pump is turned off. However, the system pumps may run to satisfy a central heat demand that is being satisfied by a different slave. The central heat demand is ignored by Slave 1 until the domestic hot water demand is ended. If domestic hot water priority is enabled and priority protection time is exceeded the domestic hot water pump turns off to allow the boiler pump to run.

X. Operation F. Changing Adjustable Parameters (continued)

Example Pump Parameter selections (continued):

Multiple boilers IWH Piped to Primary, Optional Domestic Hot Water Priority

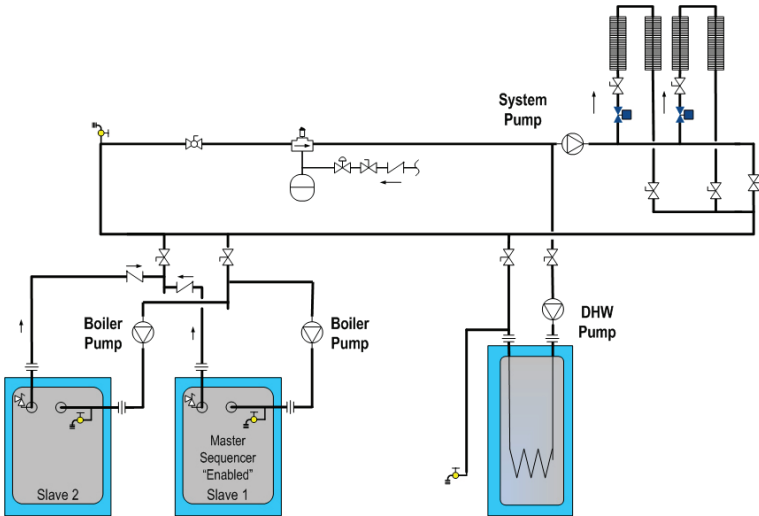

	Sequencer Master (Boiler 1)	Boiler 2
Wiring locations:		
Thermostat	X	
DHW call for heat	X	
System pump	X	
DHW pump	X	
Boiler Pump	X	X
Sequencer Master Parameter Selections:		
Sequencer Master	Enabled	
Indirect Water Heater	"Primary Piped"	
Pump Parameter Selections:		
System Pump =	Central Heat, Optional Priority	Never
Boiler Pump =	Any demand	Any demand
DHW Pump =	Primary Loop Piped IWH	Never

Explanation:

This piping arrangement permits the system pump to run or not run when there is a domestic hot water call for heat. Domestic hot water priority is optional. It is permissible for the domestic and system pumps to run at the same time. The boiler pump must run for every call for heat.

Multiple Boilers, IWH piped to primary, system pump required to run for any call for heat

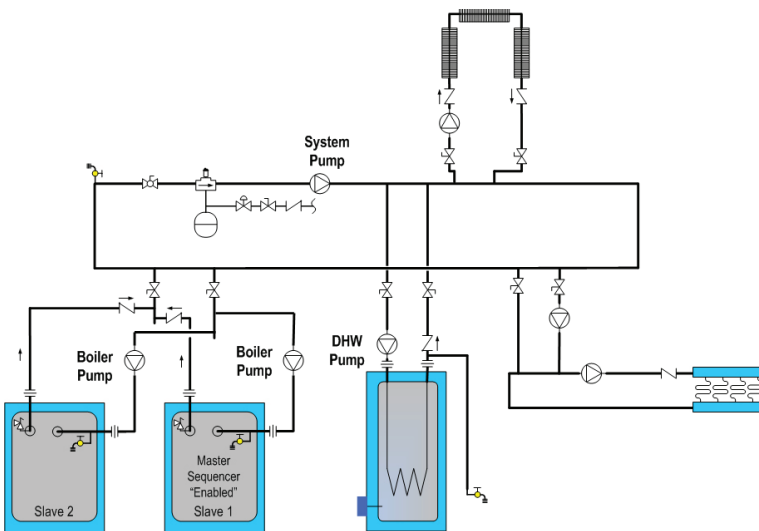

	Sequencer Master (Boiler 1)	Boiler 2
Wiring locations:		
Thermostat	X	
DHW call for heat	X	
System pump	X	
DHW pump	X	
Boiler Pump	X	X
Sequencer Master Parameter Selections:		
Sequencer Master	Enabled	
Indirect Water Heater	"Primary Piped"	
Pump Parameter Selections:		
System Pump =	Any demand	Never
Boiler Pump =	Any demand	Any demand
DHW Pump =	Primary Loop Piped IWH	Never

Explanation:

This piping arrangement requires the system pump to be running for any calls for heat. Also the boiler pump must run for any call for heat.

X. Operation F. Changing Adjustable Parameters (continued)

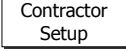
“Press”  button to access the following parameters:

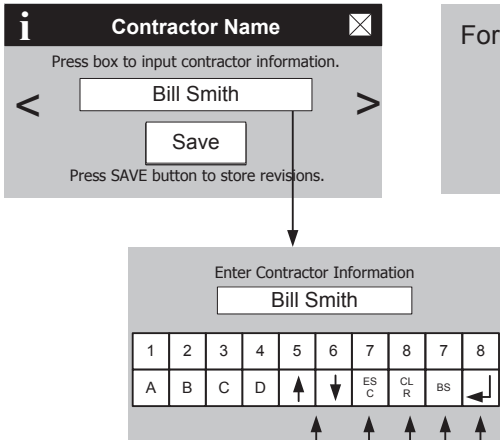

The Contractor Name screen shows a text input field with "Bill Smith" and a "Save" button. Below it is a detailed keypad with the following layout:

1	2	3	4	5	6	7	8	7	8
A	B	C	D	↑	↓	ES C	CL R	BS	↵

Use Up and DOWN Arrows for More
 Exit Screen without Saving
 Clear Entire Field
 Backspace
 Save Field and Exit

For Service Contact:
 Bill Smith
 12 Victory Lane
 Plainview, New York
 516 123-4567
 Example Screen

Factory Setting	Range / Choices	Parameter and Description
Contractor Name	User defined	Contractor Name
Address Line 1	User defined	Contractor Address Line 1
Address Line 2	User defined	Contractor Address Line 2
Phone	User defined	Contractor Phone

“Press”  button to access the following screen:

The Manual Speed Control speed screen allows the technician to set firing rate at low or high speed for combustion testing.

NOTE
 Rate % can only be set when the boiler has heat demand and is released to modulate.

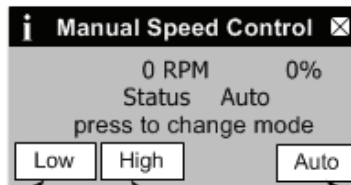

Manual Speed Control screen displays: 0 RPM, 0%, Status Auto, and buttons for Low, High, and Auto.

“Press” “Low” to select manual firing rate control and Minimum firing rate %

“Press” “High” to select manual firing rate control and Central Heat Maximum firing rate %

Press “Auto” to return firing rate to Automatic Mode

NOTE
 Selecting “Low” or “High” locks (manual mode) firing rate at min or max Rate %. After combustion testing select “Auto” to return the boiler to normal operation.

X. Operation F. Changing Adjustable Parameters (continued)

“Press” Central Heat button to access the following parameters:

Factory Setting	Range / Choices	Parameter and Description
180°F (82.2°C)	60°F to 190°F (16°C to 87.8°C)	Central Heat Setpoint Target temperature for the central heat priority. Value also used by the outdoor air reset function.
170°F (76.7°C)	80°F to 190°F (26.7°C to 87.8°C)	Central Heat Thermostat “Sleep” or “Away” Setback Setpoint Thermostat setback setpoint is used when the EnviraCOM thermostat is in “leave” or “sleep” modes and sensed at E-COM terminals D, R, and C. When setback is “on” the thermostat setback setpoint shifts the reset curve to save energy while home is in a reduced room temperature mode. The reset curve is shifted by the difference between the High Boiler Water Temperature and the Thermostat Setback Setpoint. Honeywell VisionPro IAQ part number TH9421C1004 is a “setback” EnviraCOM enabled thermostat. When connected, it allows boiler water setback cost savings.
7°F (3.9°C)	2°F to 10°F (1.1°C to 5.6°C)	Central Heat Diff Above The boiler stops when the water temperature rises ‘Diff Above’ degrees above the setpoint.
5°F (2.8°C)	2°F to 25°F (1.1°C to 14°C)	Central Heat Diff Below The boiler starts when the water temperature drops ‘Diff Below’ degrees below the setpoint.
3	1 to 5	Response Speed This parameter adjusts the Central Heat temperature controller Proportion Integral Derivative (PID) values. Higher values cause a larger firing rate change for each degree of temperature change. If set too high firing rate “overshoots” required value, increases to high fire causing the temperature to exceed the “Diff Above” setpoint and cycle the boiler unnecessarily. Lower values cause a smaller firing rate change for each degree of temperature change. If set too low, the firing rate response will be sluggish and temperature will wander away from setpoint.
120 seconds	0 to 300 seconds	Low Fire Hold Time “Low Fire Hold Time” is the number of seconds the control will wait at low fire modulation rate before being released to modulate. After ignition and flame stabilization periods the firing rate is held at low fire for “Low Fire Hold Time”. This delay allows heat to travel out to the system and provide system feedback prior to the control modulating firing rate.
Supply Sensor	Supply Sensor, Header Sensor	Modulation Sensor Heat Demand may respond to the boiler’s Supply Temperature or Header Temperature sensors. When Header Sensor is selected the boiler is fired in response to the sensor wired to Header Sensor Low Voltage Terminal Block Terminals.

X. Operation F. Changing Adjustable Parameters (continued)

“Press”

Auxiliary Heat

 button to access the following parameters:

Factory Setting	Range / Choices	Parameter and Description
180°F (82.2°C)	60°F to 190°F (16°C to 87.8°C)	Auxiliary Heat Setpoint Target temperature for the Auxiliary Heat priority. Value also used by the outdoor air reset function.
170°F (76.7°C)	80°F to 190°F (26.7°C to 87.8°C)	Auxiliary Heat Thermostat “Sleep” or “Away” Setback Setpoint Thermostat setback setpoint is used when the EnviraCOM thermostat is in “leave” or “sleep” modes and sensed at E-COM terminals D, R, and C. When setback is “on” the thermostat setback setpoint shifts the reset curve to save energy while home is in a reduced room temperature mode. The reset curve is shifted by the difference between the High Boiler Water Temperature and the Thermostat Setback Setpoint. Honeywell VisionPro IAQ part number TH9421C1004 is a “setback” EnviraCOM enabled thermostat. When connected, it allows boiler water setback cost savings.
7°F (3.9°C)	2°F to 10°F (1.1°C to 5.6°C)	Auxiliary Heat Diff Above The boiler stops when the water temperature rises ‘Diff Above’ degrees above the setpoint.
5°F (2.8°C)	2°F to 25°F (1.1°C to 14°C)	Auxiliary Heat Diff Below The boiler starts when the water temperature drops ‘Diff Below’ degrees below the setpoint.
3	1 to 5	Response Speed This parameter adjusts the Auxiliary Heat temperature controller Proportion Integral Derivative (PID) values. Higher values cause a larger firing rate change for each degree of temperature change. If set too high firing rate “overshoots” required value, increases to high fire causing the temperature to exceed the “Diff Above” setpoint and cycle the boiler unnecessarily. Lower values cause a smaller firing rate change for each degree of temperature change. If set too low, the firing rate response will be sluggish and temperature will wander away from setpoint.
Disable	Disable, Enable	Auxiliary Priority Over Central Heat This parameter allows the Auxiliary Heat demand to be higher or lower priority than Central Heat demand. When both demands are active at the same time the Control uses the Setpoint, Diff Above and Diff Below for the demand that has priority. Disabled Auxiliary Heat is lower priority than Central Heat demand. Enable Auxiliary Heat is higher priority than Central Heat demand.
Zone Control	Zone Control, DHW Terminal	Auxiliary Heat Demand Source The Control’s “DHW Temp Switch” input terminal may be used as a Domestic Hot Water (DHW) demand or Auxiliary Heat demand. When the Domestic Hot Water Demand Source is set to Zone Control and the Auxiliary Heat Demand Source is set to “DHW Terminal” an Auxiliary Heat Demand may be wired to the DHW Temp Switch terminals. This feature may be used even if a Zone Control is not installed. Zone Control Auxiliary Heat demand may only be wired to the Zone Control DHW Terminal Auxiliary Heat demand may be wired to the Zone Control or DHW Terminal.
Supply Sensor	Supply Sensor, Header Sensor	Modulation Sensor Heat Demand may respond to the boiler’s Supply Temperature or Header Temperature sensors. When Header Sensor is selected the boiler is fired in response to the sensor wired to Header Sensor Low Voltage Terminal Block Terminals.

X. Operation F. Changing Adjustable Parameters (continued)

“Press” Domestic Hot Water button to access the following parameters:

Factory Setting	Range / Choices	Parameter and Description
170°F (76.7°C)	60°F (16°C) to 190°F (26.7°C to 87.8°C)	Domestic Hot Water Setpoint The Domestic Hot Water (DHW) Setpoint parameter is used to create a minimum boiler water temperature setpoint that is used when DHW heat demand is “on”. When the DHW heat demand is not “on” (the contact is open or <u>not wired</u>) this setpoint is ignored.
160°F (71.1°C)	60°F (16°C) to 190°F (26.7°C to 87.8°C)	Domestic Hot Water Thermostat “Sleep” or “Away” Setback Setpoint Thermostat setback setpoint is used when the EnviraCOM thermostat is in “leave” or “sleep” modes and sensed at E-COM terminals D, R, and C. When setback is “on” the thermostat setback setpoint shifts the DHW setpoint to lower the DHW temperature and to save energy while home is in a reduced room temperature mode.
7°F (3.9°C)	2°F to 10°F (1.1°C to 5.6°C)	Domestic Hot Water Diff Above The boiler stops when the water temperature rises ‘Diff Above’ degrees above the setpoint.
5°F (2.8°C)	2°F to 25°F (1.1°C to 14°C)	Domestic Hot Water Diff Below The boiler starts when the water temperature drops ‘Diff Below’ degrees below the setpoint.
3	1 to 5	Response Speed This parameter adjusts the Domestic Hot Water temperature controller Proportion Integral Derivative (PID) values. Higher values cause a larger firing rate change for each degree of temperature change. If set too high firing rate “overshoots” required value, increases to high fire causing the temperature to exceed the “Diff Above” setpoint and cycle the boiler unnecessarily. Lower values cause a smaller firing rate change for each degree of temperature change. If set too low, the firing rate response will be sluggish and temperature will wander away from setpoint.
10 seconds	0 to 300 seconds	Low Fire Hold Time “Low Fire Hold Time” is the number of seconds the control will wait at low fire modulation rate before being released to modulate. After ignition and flame stabilization periods the firing rate is held at low fire for “Low Fire Hold Time”. This delay allows heat to travel out to the indirect water heater and provide feedback prior to the control modulating firing rate.
Enabled	Enable, Disable	Domestic Hot Water Priority (DHWP) When Domestic Hot Water Priority is Enabled and Domestic Hot Water (DHW) heat demand is “on” the DHW demand will take “Priority” over home heating demand. When the System and Boiler pumps are configured as “Central Heat (off DHW priority)” or “Central Heat, Optional Priority” then they will be forced “off” during DHW Priority. Priority protection time is provided to end DHWP in the event of a failed or excessive long DHW demand.
60	30 to 120 Minutes	Priority Time When DHWP is Enabled the Priority Time Parameter appears and is adjustable.
DHW Terminal	DHW Terminal, Zone Control	Domestic Demand Source The Control’s “DHW Temp Switch” input terminal may be used as a DHW demand or Auxiliary Heat demand. When “DHW Terminal” is selected the Control will accept a DHW input from either the “DHW Temp Switch” or the Zone Control (zone 4, set to priority). If “Zone Control” is selected the Control can only accept the DHW input from the Zone Control. This allows the Control to be set to accept an Auxiliary heat demand from the “DHW Temp Switch” input terminal. Refer to the Auxiliary heat menu for required selection to use this input. DHW Terminal DHW demand may be wired to the DHW Switch terminal or Zone Control. Zone Control DHW demand may only be wired to the Zone Control.

X. Operation F. Changing Adjustable Parameters (continued)

“Press” Outdoor Reset
Central Heat button to access the following parameters:

Factory Setting	Range / Choices	Parameter and Description
Enabled	Enable Disable	<p>Central Heat Outdoor Reset Enable If an outdoor sensor is installed and Outdoor Reset is Enabled, the boiler will automatically adjust the heating zone set point temperature based on the outdoor reset curve in Figure 45. The maximum set point is defined by the Central Heat Setpoint [factory set to 180°F (82.2°C)] when the outdoor temperature is 0°F (-18°C) or below. The minimum set point temperature shown is 130°F (54.4°C) [adjustable as low as 80°F (26.7°C)] when the outdoor temperature is 50°F (10°C) or above. As the outdoor temperature falls the supply water target temperature increases. For example, if the outdoor air temperature is 30°F, (-1.1°C) the set point temperature for the supply water is 150°F (65.6°C).</p> <p>Disable <u>Do Not</u> Calculate setpoint based on outdoor temperature Enable Calculate the temperature setpoint based on outdoor temperature using a reset curve defined by Low Outdoor Temp, High Outdoor Temp, Low Boiler Water Temp, Min Boiler Temp and Central Heat Setpoint and Boost Time parameters.</p>
0°F (-18°C)	-40°F to 100°F (-40°C to 37.8°C)	<p>Central Heat Low Outdoor Temperature The Low Outdoor Temperature parameter is also called “Outdoor Design Temperature”. This parameter is the outdoor temperature used in the heat loss calculation. It is typically set to the coldest outdoor temperature.</p>
70°F (21.1°C)	32°F to 100°F (0°C to 37.8°C)	<p>Central Heat High Outdoor Temperature The High Outdoor Temperature parameter is the outdoor temperature at which the Low Boiler Water Temperature is supplied. This parameter is typically set to the desired building temperature.</p>
110°F (43.3°C)	70°F to 190°F (21.1°C to 87.8°C)	<p>Central Heat Low Boiler Water Temperature The Low Boiler Water Temperature parameter is the operating setpoint when the High Outdoor Temperature is measured. If the home feels cool during warm outdoor conditions, the Low Boiler Water Temperature parameter should be increased.</p>
130°F (54.4°C)	80°F to 190°F (26.7°C to 87.8°C)	<p>Minimum Boiler Temperature (Central Heat and Auxiliary Heat) The Minimum Boiler Temperature parameter sets a low limit for the Reset setpoint. Set this parameter to the lowest supply water temperature that will provide enough heat for the type radiation used to function properly. Always consider the type of radiation when adjusting this parameter.</p>
0 Minutes	0-1800 Seconds (0-30 Minutes)	<p>Central Heat Boost Time When the Central Heat Setpoint is decreased by Outdoor Reset settings, the Boost Time parameter is used to increase the operating setpoint when the home heat demand is not satisfied after the Boost Time setting is exceeded. When heat demand has been “on” continuously for longer than the Boost Time parameter the operating setpoint is increased by 10°F (5.6°C). The highest operating setpoint from Boost Time is current Central Heat Setpoint minus the Central Heat “Diff Above” setting. A setting of 0 seconds disables this feature.</p>

X. Operation F. Changing Adjustable Parameters (continued)

“Press” Outdoor Reset
Auxiliary Heat button to access the following parameters:

Factory Setting	Range / Choices	Parameter and Description
Enabled	Enable Disable	<p>Auxiliary Heat Outdoor Reset Enable If an outdoor sensor is installed and Outdoor Reset is Enabled, the boiler will automatically adjust the heating zone set point temperature based on the outdoor reset curve in Figure 45. The maximum set point is defined by the Central Heat Setpoint [factory set to 180°F (82.2°C)] when the outdoor temperature is 0°F (-18°C) or below. The minimum set point temperature shown is 130°F (54.4°C) [adjustable as low as 80°F (26.7°C)] when the outdoor temperature is 50°F (10°C) or above. As the outdoor temperature falls the supply water target temperature increases. For example, if the outdoor air temperature is 30°F, (-1.1°C) the set point temperature for the supply water is 150°F (65.6°C).</p> <p>Disable <u>Do Not</u> Calculate setpoint based on outdoor temperature Enable Calculate the temperature setpoint based on outdoor temperature using a reset curve defined by Low Outdoor Temp, High Outdoor Temp, Low Boiler Water Temp, Min Boiler Temp and Central Heat Setpoint and Boost Time parameters.</p>
0°F (-18°C)	-40°F to 100°F (-40°C to 37.8°C)	<p>Auxiliary Heat Low Outdoor Temperature The Low Outdoor Temperature parameter is also called “Outdoor Design Temperature”. This parameter is the outdoor temperature used in the heat loss calculation. It is typically set to the coldest outdoor temperature.</p>
70°F (21.1°C)	32°F to 100°F (0°C to 37.8°C)	<p>Auxiliary Heat High Outdoor Temperature The High Outdoor Temperature parameter is the outdoor temperature at which the Low Boiler Water Temperature is supplied. This parameter is typically set to the desired building temperature.</p>
110°F (43.3°C)	70°F to 190°F (21.1°C to 87.8°C)	<p>Auxiliary Heat Low Boiler Water Temperature The Low Boiler Water Temperature parameter is the operating setpoint when the High Outdoor Temperature is measured. If the home feels cool during warm outdoor conditions, the Low Boiler Water Temperature parameter should be increased.</p>
0 Minutes	0-1800 Seconds (0-30 Minutes)	<p>Auxiliary Heat Boost Time When the Central Heat Setpoint is decreased by Outdoor Reset settings, the Boost Time parameter is used to increase the operating setpoint when the home heat demand is not satisfied after the Boost Time setting is exceeded. When heat demand has been “on” continuously for longer than the Boost Time parameter the operating setpoint is increased by 10°F (5.6°C). The highest operating setpoint from Boost Time is current Central Heat Setpoint minus the Central Heat “Diff Above” setting. A setting of 0 seconds disables this feature.</p>

X. Operation G. Changing Adjustable Parameters (continued)

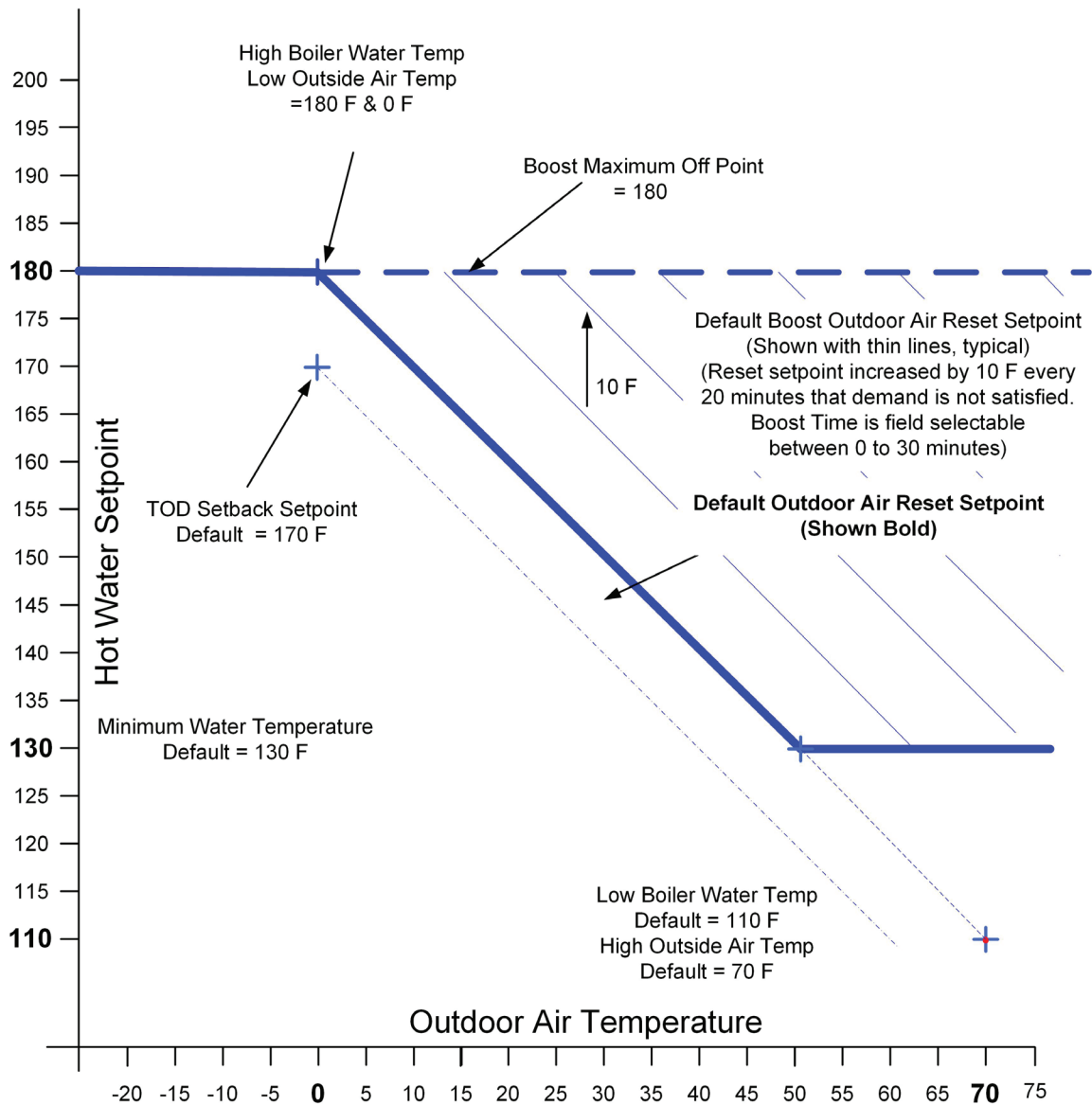
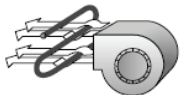
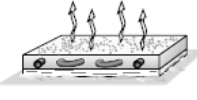
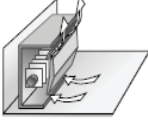
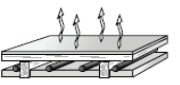



Figure 44: Outdoor Reset Curve

Central Heat Setpoint	Heating Element Type		Central Heat Setpoint	Heating Element Type	
180°F to 190°F (82.2°C to 87.8°C)	Fan Coil		100°F to 140°F (37.8°C to 60°C)	In Slab Radiant High Mass Radiant	
160°F to 190°F (71.1°C to 87.8°C)	Convection Baseboard Fin Tube Convective		130°F to 160°F (54.4°C to 71.1°C)	Staple-up Radiant Low Mass Radiant	
130°F to 160°F (54.4°C to 71.1°C)	Radiant Baseboard		140°F to 160°F (60°C to 71.1°C)	Radiators	

X. Operation F. Changing Adjustable Parameters (continued)

“Press” Sequence Master button to access the following parameters:

Factory Setting	Range / Choices	Parameter and Description
Disable	Enable, Disable	Master Enable/Disable The Sequencer Master Enable/Disable is used to “turn on” the Multiple Boiler Controller. Warning! enable ONLY one Sequence Master.
Boiler Piped	Boiler Piped, Primary Piped	Indirect Water Heater (IWH) Boiler Piped Sequencer to respond to an Isolated DHW demand that is piped to a single boiler. The individual boiler goes on “Leave” from the Sequencer Master and goes to DHW Service. Primary Piped The Sequence Master responds to the DHW Call For Heat. This allows one or more boilers to provide heat to the IWH.
Disabled	Enable, Disable	DHW Two Boiler Start The Sequencer to immediately start two boilers for a DHW call for heat. Used when DHW is the largest demand. Only visible when primary piped IWH is selected.
180 Secs	120 - 1200 Secs	Boiler Start Delay Slave boiler time delay after header temperature has dropped below the setpoint minus “Diff below” setpoint. Longer time delay will prevent nuisance starts due to short temperature swings.
195°F (90.6°C)	Central Heat Setpoint, 195°F (90.6°C)	Stop All Boilers Setpoint When this temperature is reached all boilers are stopped. This setpoint allows the Sequencer to respond to rapid load increases.
70%	50% - 100%	Base Load Common Rate To maximize condensing boiler efficiency, the firing rate is limited to an adjustable value. Boilers are kept at or below this firing rate as long as the boilers can handle the load. After last available boiler has started, the modulation rate limit is released up to 100%.
3	1-5	Response Speed This parameter adjusts the Sequence Master temperature controller Proportion Integral Derivative (PID) values. Higher values cause a larger firing rate change for each degree of temperature change. If set too high firing rate “overshoots” required value, increases to high fire causing the temperature to exceed the “Diff Above” setpoint and cycle the boiler unnecessarily. Lower values cause a smaller firing rate change for each degree of temperature change. If set too low, the firing rate response will be sluggish and temperature will wander away from setpoint.

“Press” Sequence Slave button to access the following parameters:

Factory Setting	Range / Choices	Parameter and Description
None	1-8	Boiler Address Each boiler must be given a unique address. When “Normal” slave selection order is used, the boiler address is used by the Master Sequencer as the boiler start order. The boiler address is also the Modbus Address when a Energy Management System is connected.
Normal	Use Boiler First, Normal, Use Boiler Last	Slave Selection Order “Use Boiler First”; places the Slave in the lead permanently. “Normal”; firing order follows boiler number (1,2,3,...) order. “Use Boiler Last”; places the slave last in the firing order.

X. Operation F. Changing Adjustable Parameters (continued)

“Press” Zone Control Description Setup button to access the following parameters:

NOTE
Zone Control Description Setup shown for 2 panels, typical for up to 4.

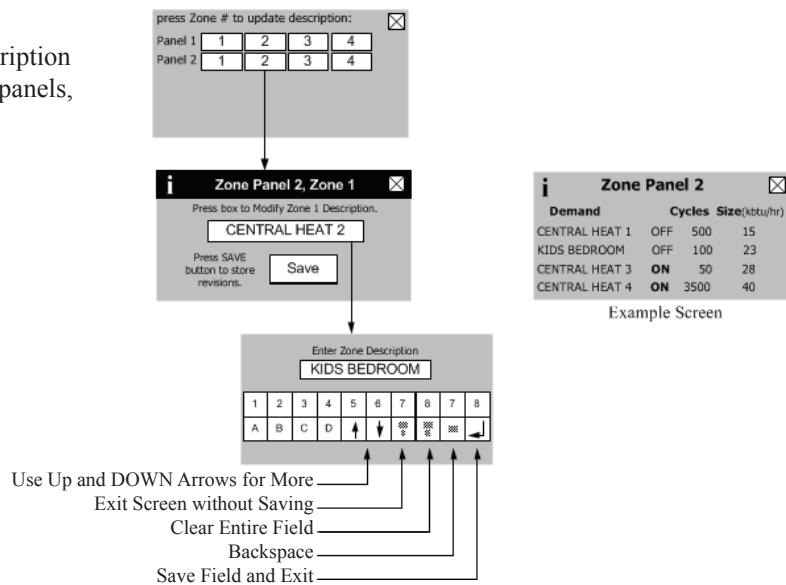

Factory Setting	Range / Choices	Parameter and Description	
Central Heat 1	User defined	Zone Control 1	Zone 1
Central Heat 2	User defined	Zone Control 1	Zone 2
Central Heat 3	User defined	Zone Control 1	Zone 3
Central Heat 4	User defined	Zone Control 1	Zone 4
Central Heat 1	User defined	Zone Control 2	Zone 1
Central Heat 2	User defined	Zone Control 2	Zone 2
Central Heat 3	User defined	Zone Control 2	Zone 3
Central Heat 4	User defined	Zone Control 2	Zone 4
Central Heat 1	User defined	Zone Control 3	Zone 1
Central Heat 2	User defined	Zone Control 3	Zone 2
Central Heat 3	User defined	Zone Control 3	Zone 3
Central Heat 4	User defined	Zone Control 3	Zone 4
Central Heat 1	User defined	Zone Control 4	Zone 1
Central Heat 2	User defined	Zone Control 4	Zone 2
Central Heat 3	User defined	Zone Control 4	Zone 3
Central Heat 4	User defined	Zone Control 4	Zone 4

X. Operation F. Changing Adjustable Parameters (continued)

Factory Setting	Range / Choices	Parameter and Description
Local	Local, 4-20mA	<p>Central Heat Modulation Source This parameter enables the 4-20mA input to control firing rate and the thermostat input to control boiler on/off demand directly without using the internal setpoint. The 4-20mA selection is used to enable a remote multiple boiler controller to control the R7910 Control:</p> <p>Local: 4-20mA Input on Terminal 9 & 10 is ignored. 4-20mA 4-20mA Input on Terminal 9 & 10 is used to control firing Rate % directly. Modbus Modbus input used to control firing Rate % directly.</p>
Local	Local, 4-20mA	<p>Central Heat Setpoint Source Sets the remote (Energy Management System) control mode as follows:</p> <p>Local: Local setpoint and modulation rate is used. 4-20mA input on Terminal 9 & 10 is ignored. 4-20mA 4-20mA Input on Terminal 9 & 10 is used as the temperature setpoint. The following two parameters may be used to adjust the signal range. Modbus Modbus is used as the temperature setpoint.</p>
130°F (54.4°C)	80°F (26.7°C) - Central Heat Setpoint	<p>Central Heat 4-20mAdc Setup, 4 mA Water Temperature* Sets the Central Heat Temperature Setpoint corresponding to 4mA for signal input on terminal 9 & 10. Current below 4mA is considered invalid, (failed or incorrect wired input).</p>
180°F (82.2°C)	80°F (26.7°C) - Central Heat Setpoint	<p>Central Heat 4-20mAdc Setup, 20 mA Water Temperature* Sets the Central Heat Temperature Setpoint corresponding to 20mA for signal input on terminal 9 & 10. Current above 20mA is considered invalid, (failed or incorrect wired input).</p>
Local	Local, Modbus	<p>Central Heat Demand Source This parameter enables a Modbus input to be take the place of the Heating Thermostat Input:</p> <p>Local Local Heating Thermostat input is used for Central Heat demand. Modbus Modbus input is used for Central Heat demand.</p>

* Only visible when Central Heat Setpoint Source is set to 4-20mA.

Important Product Safety Information **Refractory Ceramic Fiber Product**

Warning:

The Repair Parts list designates parts that contain refractory ceramic fibers (RCF). RCF has been classified as a possible human carcinogen. When exposed to temperatures above 1805°F, such as during direct flame contact, RCF changes into crystalline silica, a known carcinogen. When disturbed as a result of servicing or repair, these substances become airborne and, if inhaled, may be hazardous to your health.

AVOID Breathing Fiber Particulates and Dust

Precautionary Measures:

Do not remove or replace RCF parts or attempt any service or repair work involving RCF without wearing the following protective gear:

1. A National Institute for Occupational Safety and Health (NIOSH) approved respirator
 2. Long sleeved, loose fitting clothing
 3. Gloves
 4. Eye Protection
- Take steps to assure adequate ventilation.
 - Wash all exposed body areas gently with soap and water after contact.
 - Wash work clothes separately from other laundry and rinse washing machine after use to avoid contaminating other clothes.
 - Discard used RCF components by sealing in an airtight plastic bag. RCF and crystalline silica are not classified as hazardous wastes in the United States and Canada.

First Aid Procedures:

- If contact with eyes: Flush with water for at least 15 minutes. Seek immediate medical attention if irritation persists.
- If contact with skin: Wash affected area gently with soap and water. Seek immediate medical attention if irritation persists.
- If breathing difficulty develops: Leave the area and move to a location with clean fresh air. Seek immediate medical attention if breathing difficulties persist.
- Ingestion: Do not induce vomiting. Drink plenty of water. Seek immediate medical attention.

XI. Service and Maintenance (continued)



WARNING

Asphyxiation Hazard. This boiler requires regular maintenance and service to operate safely. Follow the instructions contained in this manual.

Improper installation, adjustment, alteration, service or maintenance can cause property damage, personal injury or loss of life. Read and understand the entire manual before attempting installation, start-up operation, or service. Installation and service must be performed only by an experienced, skilled, and knowledgeable installer or service agency

This boiler must be properly vented.

This boiler needs fresh air for safe operation and must be installed so there are provisions for adequate combustion and ventilation air.

Asphyxiation Hazard. The interior of the venting system must be inspected and cleaned before the start of the heating season and should be inspected periodically throughout the heating season for any obstructions. A clean and unobstructed venting system is necessary to allow noxious fumes that could cause injury or loss of life to vent safely and will contribute toward maintaining the boiler's efficiency.

Installation is not complete unless a safety relief valve is installed into the tapping located on left side of appliance or the supply piping. - See the Water Piping and Trim Section of this manual for details.

This boiler is supplied with safety devices which may cause the boiler to shut down and not re-start without service. If damage due to frozen pipes is a possibility, the heating system should not be left unattended in cold weather; or appropriate safeguards and alarms should be installed on the heating system to prevent damage if the boiler is inoperative.

Burn Hazard. This boiler contains very hot water under high pressure. Do not unscrew any pipe fittings nor attempt to disconnect any components of this boiler without positively assuring the water is cool and has no pressure. Always wear protective clothing and equipment when installing, starting up or servicing this boiler to prevent scald injuries. Do not rely on the pressure and temperature gauges to determine the temperature and pressure of the boiler. This boiler contains components which become very hot when the boiler is operating. Do not touch any components unless they are cool.

Respiratory Hazard. Boiler materials of construction, products of combustion and the fuel contain alumina, silica, heavy metals, carbon monoxide, nitrogen oxides, aldehydes and/or other toxic or harmful substances which can cause death or serious injury and which are known to the state of California to cause cancer, birth defects and other reproductive harm. Always use proper safety clothing, respirators and equipment when servicing or working nearby the appliance.

Failure to follow all instructions in the proper order can cause personal injury or death. Read all instructions, including all those contained in component manufacturers manuals which are provided with the boiler before installing, starting up, operating, maintaining or servicing.

All cover plates, enclosures and guards must be in place at all times.

NOTICE

This boiler has a limited warranty, a copy of which is printed on the back of this manual. It is the responsibility of the installing contractor to see that all controls are correctly installed and are operating properly when the installation is complete.

XI. Service and Maintenance (continued)



DANGER

Explosion Hazard. Electrical Shock Hazard. Burn Hazard. This boiler uses flammable gas, high voltage electricity, moving parts, and very hot water under high pressure. Assure that all gas and electric power supplies are off and that the water temperature is cool before attempting any disassembly or service.

Do not attempt any service work if gas is present in the air in the vicinity of the boiler. Never modify, remove or tamper with any control device.



WARNING

This boiler must only be serviced and repaired by skilled and experienced service technicians.

If any controls are replaced, they must be replaced with identical models.

Read, understand and follow all the instructions and warnings contained in all the sections of this manual.

If any electrical wires are disconnected during service, clearly label the wires and assure that the wires are reconnected properly.

Never jump out or bypass any safety or operating control or component of this boiler.

Read, understand and follow all the instructions and warnings contained in ALL of the component instruction manuals.

Assure that all safety and operating controls and components are operating properly before placing the boiler back in service.

Annually inspect all vent gaskets and replace any exhibiting damage or deterioration.

NOTICE

Warranty does not cover boiler damage or malfunction if the following steps are not performed at the intervals specified.

A. Continuously:

1. Keep the area around the boiler free from combustible materials, gasoline and other flammable vapors and liquids.
2. Keep the area around the combustion air inlet terminal free from contaminants.
3. Keep the boiler room ventilation openings open and unobstructed.

B. Monthly Inspections:

1. Inspect the vent piping and outside air intake piping to verify they are open, unobstructed and free from leakage or deterioration. Check rodent screens in vent and air intake terminations to verify they are clean and free of debris. Call the service technician to make repairs if needed.
2. Inspect the condensate drain system to verify it is leak tight, open and unobstructed. Call the service technician if the condensate drain system requires maintenance.

3. Inspect the flue temperature sensor cap to verify that it is free from leakage and deterioration. Call the service technician to make repairs, if needed.
4. Inspect the water and gas lines to verify they are free from leaks. Call the service technician to make repairs if required.

NOTICE

Water leaks can cause severe corrosion damage to the boiler or other system components. Immediately repair any leaks found.

C. Annual Inspections and Service: In addition to the inspections listed above the following should be performed by a service technician once every year.

1. Test the flow switch by disabling the boiler primary loop circulator. The boiler must not start when there is not water flow.
2. Follow the procedure for turning the boiler off per Figure 34 “Operating Instructions”.
3. Inspect the wiring to verify the conductors are in good condition and attached securely.

XI. Service and Maintenance (continued)



CAUTION / ATTENTION

Electrical Shock Hazard. Label all wires prior to disconnection when servicing controls. Wiring errors can cause improper and dangerous operation. Verify proper operation after servicing.

Au moment de l'entretien des commandes, étiquetez tous les fils avant de les débrancher. Les erreurs de câblage peuvent nuire au bon fonctionnement et être dangereuses.

S'assurer que l'appareil fonctionne adéquatement une fois l'entretien terminé.

4. Remove the igniter assembly and flame sensor and inspect them for oxide deposits. Clean the oxide deposits from the igniter electrodes and flame sensor rod with steel wool. Do not use sandpaper for the cleaning. Inspect the ceramic insulators for cracks and replace the igniter assembly and/or flame sensor if necessary. Check the igniter electrode spacing gap. Refer to Figure 45 "Igniter Electrode Gap" for details.

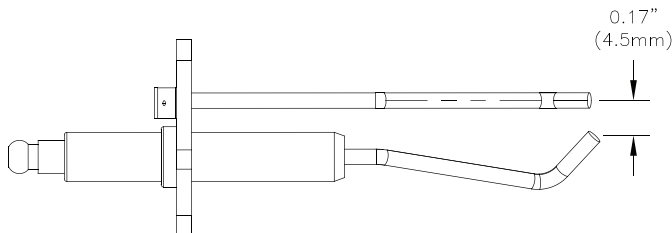

Figure 45: Igniter Electrode Gap

5. To gain access to boiler burner and combustion chamber, first disconnect and remove gas inlet piping from gas valve. Then, remove six M6X1 hex flange nuts and take out the burner/blower/gas valve assembly from the boiler. To prevent stud breakage, apply a generous amount of good quality penetrating oil to nuts and let it soak in prior to attempting nut removal.
6. Inspect the assembly for lint and dust presence. If significant lint and dust accumulations are found, disassemble the blower/gas valve assembly to expose the swirl plate and blower inlet. For parts identification, refer to Section XIII "Repair Parts". Vacuum these parts as required, being careful not to damage the vanes on the swirl plate.
7. Vacuum any dust or lint from the burner if present. If the burner shows any visual deterioration or corrosion signs, replace it immediately. Inspect the burner gasket and replace if necessary.
8. Inspect the heat exchanger combustion chamber, clean and vacuum any debris found on the surfaces. If required, brush the coils of the heat exchanger using a non-abrasive, non-metal bristle brush. Any cleaning of the combustion chamber with acid or alkali products is

prohibited. Do not use any cleaning agents or solvents. If insulation disc has signs of damage, it must be replaced.

9. Inspect the condensate trap to verify it is open and free from debris. Inspect condensate line integrity between boiler and condensate neutralizer (if used), condensate neutralizer and the drain. Clean/repair if needed.
If the condensate neutralizer is used, check pH before and after the neutralizer to determine neutralizing effectiveness. Replace limestone chips and clean out the neutralizer if needed.
10. Inspect the flue temperature sensor cap to verify that it is free from leakage and deterioration. Replace if needed.
11. Inspect vent connections and vent connector to heat exchanger seals to verify that they are free from leakage and deterioration. Repair as needed. Follow all instructions in Section IV "Venting" when reassembling vent system.
12. Check for vent and air intake terminal for obstructions and clean as necessary. Check rodent screens in vent and air intake terminations to verify they are clean and free of debris.



WARNING

Failure to properly secure the burner/blower/gas valve assembly to the heat exchanger could lead to property damage, personal injury or loss of life.

13. Reinstall the burner/blower/gas valve assembly and secure with M6X1 hex flange nuts.
14. Reconnect any wiring which has been disconnected.
15. Verify that the system pH is between 7.5 and 9.5.
16. Inspect the heating system and correct any other deficiencies prior to restarting the boiler.
17. Follow Section IX "System Start-up" before leaving installation.
18. Perform the combustion test outlined in Section IX "System Start-up".

D. Recommended Heating System Water Treatment Products:

1. System Cleaning and Conditioning:

- a. The following heating system water treatment products are recommended for an initial existing heating system sludge removal, initial boiler cleaning from copper dust, flux residue and any boiler debris and for preventive treatment as corrosion/scale inhibitors:
 - i. Fernox™ Restorer (universal cleaner, sludge remover, scale remover, flux residue/debris remover, corrosion inhibitor)

XI. Service and Maintenance (continued)

- ii. Fernox™ Protector (Alphi 11, CH#, Copal) (sludge remover, corrosion inhibitor)

Follow manufacturer application procedure for proper heating system/boiler cleaning and preventive treatment.

Above referenced products are available from Alent plc, Consumer Products Division, 4100 6th Avenue, Altoona, PA 16602, Tel: (972) 547-6002 and/or selected HVAC distributors. Contact Thermal Solutions for specific details.

- iii. Equivalent system water treatment products may be used in lieu of products referenced above.

2. System Freeze Protection:

- a. The following heating system freeze protection products are recommended for Apex boilers:

- i. Fernox™ Protector Alphi 11 (combined antifreeze and inhibitor).

Follow manufacturer application procedure to insure proper antifreeze concentration and inhibitor level.

Above referenced product is available from Alent plc, Consumer Products Division, 4100 6th Avenue, Altoona, PA 16602, Tel: (972) 547-6002 and/or selected HVAC distributors. Contact Thermal Solutions for specific details.

- b. Equivalent system freeze protection products may be used in lieu of product referenced above. In general, freeze protection for new or existing systems must use specially formulated glycol, which contains inhibitors, preventing the glycol from attacking the metallic system components. Insure that system fluid contains proper glycol concentration and inhibitor level. The system should be tested at least once a year and as recommended by the manufacturer of the glycol solution. Allowance should be made for expansion of the glycol solution.



WARNING

Poison Hazard. Use only inhibited propylene glycol solutions specifically formulated for hydronic systems. Do not use ethylene glycol, which is toxic and can attack gaskets and seals used in hydronic systems. Use of ethylene glycol could result in property damage, personal injury or death.

E. Condensate Overflow Switch and Condensate Trap Removal and Replacement:

For removal or replacement of the condensate overflow switch and/or condensate trap follow the steps below. For parts identification, refer to Section XIII “Repair Parts”.

1. Condensate Overflow Switch Removal and Replacement:

- a. Disconnect power supply to boiler.
- b. Remove 2 wire nuts and disconnect overflow switch wire pigtails from boiler wiring.
- c. Using pliers, release spring clip securing the overflow switch to condensate trap body and remove the switch. Note that the switch has factory applied silicon adhesive seal, which may have to be carefully cut all around to facilitate the switch removal.
- d. Insure the trap overflow switch port is not obstructed with silicon seal debris, clean as needed.
- e. Apply silicon sealant to the replacement switch threads and install the switch into the trap body making sure it is properly oriented - the arrow molded into the switch hex end side must face down for proper switch operation. See Figure 46 “Condensate Overflow Switch Orientation” for details.
- f. Reconnect the switch wire pigtails to the boiler wiring and secure with wire nuts.

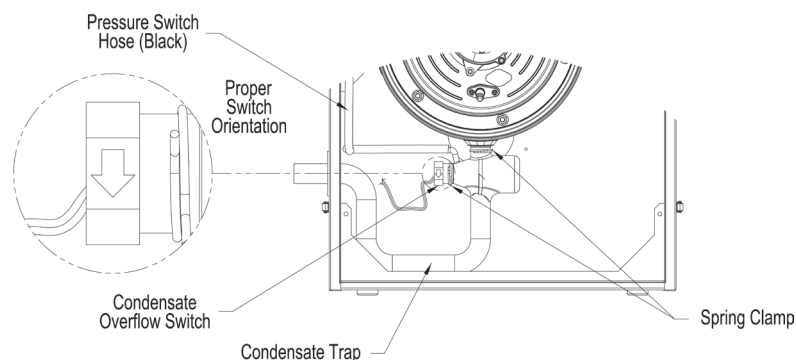

Figure 46: Condensate Overflow Switch Orientation

XI. Service and Maintenance (continued)

- g. Restore power supply to boiler. Fill up the trap (see Section V “Condensate Disposal”) and verify the switch operation.

2. Condensate Trap Removal and Reinstallation:

- Disconnect power supply to boiler.
- Remove 2 wire nuts and disconnect overflow switch wire pigtailed from boiler wiring.
- Disconnect pressure switch hose from condensate trap.
- Disconnect outside condensate compression fitting from condensate trap.
- Using pliers, release spring clip securing the overflow switch to condensate trap body and remove the switch. Note that the switch has factory applied silicon adhesive seal, which may have to be carefully cut all around to facilitate the switch removal.
- Using pliers, release spring clip securing condensate trap body to the heat exchanger bottom drain connection.
- First, pull the trap downwards to release from the heat exchanger. Second, pull the trap end from left side jacket panel sealing grommet and remove the trap from boiler.
- To reinstall the trap, reverse above steps.
- If the original condensate overflow switch is to be re-used, follow the appropriate switch removal steps from Condensate Overflow Switch Removal and Replacement procedure above.

Outdoor Air Temperature Sensor Temperature versus Resistance (P/N 102946-01)

(10kOhm NTC Sensor)

Outdoor Temperature		Ohms of Resistance
°F	°C	
-20	-28.9	106926
-10	-23.3	80485
0	-17.8	61246
10	-12.2	47092
20	-6.7	36519
30	-1.1	28558
40	4.4	22537
50	10.0	17926
60	15.6	14356
70	21.1	11578
76	24.4	10210
78	25.6	9795
80	26.7	9398
90	32.2	7672
100	37.8	6301
110	43.3	5203
120	48.9	4317

- Insure that fresh silicon sealant is applied to the overflow switch threads and the switch is properly oriented relative to the trap body - the arrow molded into the switch hex side end must face down for proper switch operation. See Figure 46 “Condensate Overflow Switch Orientation” for details.
- Insure that pressure switch hose is reconnected to the trap.
- Restore power supply to boiler. Fill up the trap (see Section V “Condensate Disposal”) and verify the switch operation.

Header Temperature Sensor Temperature versus Resistance (P/N 101935-01 or 103104-01)

(10kOhm NTC Sensor), Beta of 3950

Temperature		Ohms of Resistance
°F	°C	
32	0	32648
50	10	19898
68	20	12492
77	25	10000
86	30	8057
104	40	5327
122	50	3602
140	60	2488
158	70	1752
176	80	1256
194	90	916
212	100	697
248	120	386

Supply, Return and Stack Temperature Sensor Temperature versus Resistance

(12kOhm NTC Sensor), Beta of 3750

Temperature		Ohms of Resistance
°F	°C	
32	0	36100
50	10	22790
68	20	14770
77	25	12000
86	30	9810
104	40	6653
122	50	4610
140	60	3250
158	70	2340
176	80	1710
194	90	1270
212	100	950
230	110	730
248	120	560

XII. Troubleshooting



WARNING

Electrical Shock Hazard. Turn off power to boiler before working on wiring.

A. Troubleshooting problems where no error code is displayed.

Condition	Possible Cause
Boiler not responding to call for heat, "Status" and "Priority" show "Standby".	Boiler is not seeing call for heat. Check thermostat or zone wiring for loose connection, miswiring, or defective thermostat/zone control.
Boiler not responding to a call for heat, "Status" shows "Standby" and "Priority" shows Central Heat or Domestic Hot Water.	Boiler is not firing, temperature is greater than setpoint. Water flow through boiler primary loop non-existent or too low.
Boiler Running but System or Boiler Circulator is not running	<ul style="list-style-type: none"> Check wiring for loose connection, miswiring. Flow switch is defective and needs replacement. When there is a Domestic Hot Water Heat Request the System or Boiler pumps will be forced "off" when there "Run Pump for" parameter is set to "Central heat, off DHW demand" or "Central Heat, Optional Priority". This has been set to allow all of the heat to be provided for fast indirect water heater recovery. After one hour of "priority protection" or the end of the Domestic Hot Water Heat Request the system and boiler pumps will be free to run.
Home is cold during mild weather days	<ul style="list-style-type: none"> Increase Low Boiler Water Temperature parameter 5°F (2.8°C) per day.
Home is cold during cold weather days	<ul style="list-style-type: none"> Increase High Boiler Water Temperature parameter 5°F (2.8°C) per day

B. Display Faults:

Faults are investigated by selecting the "Help" button from the "Home" screen. When a fault is active the "Help" button flashes and the home screen turns a red color. Continue to select flashing buttons to be directed to the Fault cause.

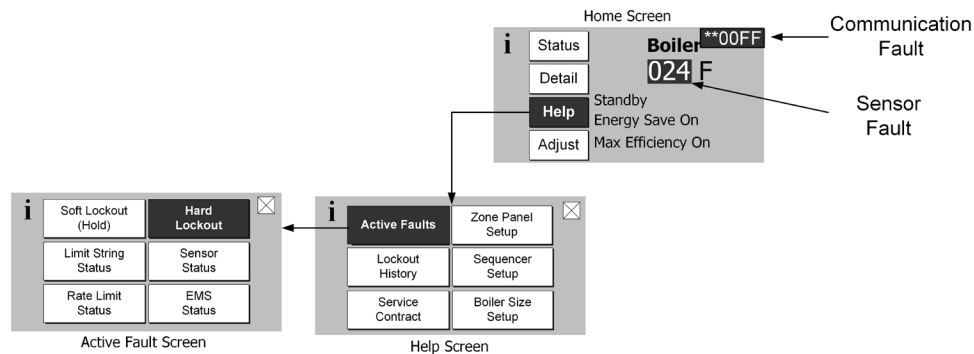

Figure 47: Help Menu

Indication	Condition	Possible Cause
Display Completely Dark Fan off, LWCO lights off, no green power light on Control	No 120Vac Power at Boiler	Check breaker and wiring between breaker panel and boiler.
Display Completely Dark, Fan running	No 24Vac Power to Control	<ul style="list-style-type: none"> Loose 120Vac connection wiring between boiler J-Box and transformer Loose 24 Vac connection wiring between transformer and Control.
Blinking Green power light on Control	Control Fault	<ul style="list-style-type: none"> The green light is connected to internal power supply. The power supply is repeatedly starting and stopping (not normal) making the light flash. The microprocessors are not running. Try disconnecting all terminals except 24VAC to power the Control. The green light should be steady. If it is not, then the control is defective. If steady, start plugging in all the connectors while watching the green light. When faulty wiring reconnected, green light will begin to flash.
Display Completely Dark but Boiler fires	No 5 Vdc Power to Display	<ul style="list-style-type: none"> Loose 5 Vdc connection wiring between display and Control Defective Display or Control.
**00FF or **ERFF	display lost communication with control	<ul style="list-style-type: none"> Loose or defective display harness Defective Display Defective Control
ER0011	Adjustment Mode Password Timeout	- The Control and Display are NOT defective. The password has timed out. Simply cycle power to the Display to restore operation.
ER0012	Control Failed	Defective Control. Replace Sage.

XII. Troubleshooting (continued)

C. Help Screen Faults

Indication	Condition	Possible Cause
<div style="background-color: black; color: white; padding: 5px; text-align: center;">Zone Panel Setup</div> Flashing	<div style="background-color: black; color: white; padding: 5px; text-align: center;">Zone Panel 1 Setup</div> Flashing	Zone Panel 1 communication lost, typical for Panel 1 through 4: The zone panel's communication was established and then lost. Check the following to correct the issue: <ul style="list-style-type: none"> • Wiring between panel and boiler. • Zone panel DIP switch settings have changed: <ul style="list-style-type: none"> - Set Master/Slave switch to "Master" - Set Zone Control switch ZC1 to "ON" - Cycle power
	<div style="background-color: black; color: white; padding: 5px; text-align: center;">Zone Panel Failure</div> Flashing	Zone Panel Electronics Failure: A Zone Panel
	<div style="background-color: black; color: white; padding: 5px; text-align: center;">Duplicate Zone</div> Flashing	Duplicate Zone: The Control has detected duplicate zone panel numbers. Check the following to correct: <ul style="list-style-type: none"> • Each Zone Control DIP Switch must be set to a Unique setting: <div style="text-align: center;"> </div> <p>Note that when multiple ZC switches are set on ON the Zone Panel is reported as Zone Panel 1.</p>
<div style="background-color: black; color: white; padding: 5px; text-align: center;">Sequencer Setup</div> Flashing	Sequencer Setup Fault	This alarm is active if the slave boiler has lost communication with the Sequence Master. Check the following: <ul style="list-style-type: none"> - RJ 45 peer-to-peer network disconnected - Sequencer Master was Enabled and then Disabled - Master's Boiler has been powered down. - To clear fault restore communication or cycle power
<div style="background-color: black; color: white; padding: 5px; text-align: center;">Boiler Size Setup</div> Flashing	Boiler Size Fault	<p style="text-align: center;">WARNING!</p> Boiler size setting may not match actual boiler size. The Boiler size setting determines min, max and light-off blower speeds. Incorrect boiler size can cause hazardous burner conditions and improper operation that may result in PROPERTY LOSS, PHYSICAL INJURY, OR DEATH. Refer to page 89 for boiler size setting instructions.

D. Help Screen Diagnostic Features

Indication	Possible Cause
	Lockout History is stored in a first-in, first-out basis. Each History file is stored with boiler run hour of when the lockout occurred. The "When happened" and "Current" provide: <ul style="list-style-type: none"> - "Current" is the run hour and status the boiler just finished. - "When happened" is the run hour and status when the lockout occurred.
For Service Contact: <input checked="" type="checkbox"/> CONTRACTOR NAME CONTRACTOR ADDRESS 1 CONTRACTOR ADDRESS 2 PHONE NUMBER	The user is given the contact information of the responsible service provider. Refer to page 95 for data entry instructions.

XII. Troubleshooting (continued)

E. Active Fault Screen Faults

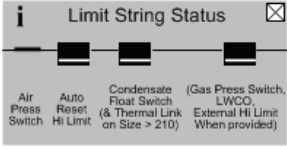
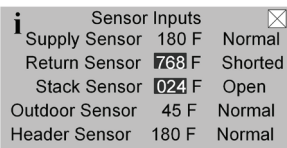
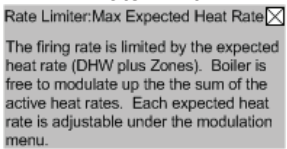
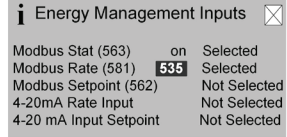
Indication	Condition	Possible Cause
<p>Limit String Status</p>  <p>Air Press Switch Auto Reset Hi Limit Condensate Float Switch (& Thermal Link on Size > 210) (Gas Press Switch, LWCO, External Hi Limit When provided)</p>	Limit String Fault	<p>The Limit String Status screen shows the faulty safety limit. A contact icon, either “open” or “closed”, graphically represents each safety limit. The “closed” contact icon is steady; the “open” contact icon is blinking. For example, the screen shown to the left illustrates a “closed” Air Pressure Switch contact and an “open” Auto Reset High Limit contact. The Auto Reset High Limit is causing the boiler to stop firing.</p> <p>NOTE: Since the limit string items are wired in series, all limits downstream of the “open” limit will also appear on the screen as “open” (blinking) icons regardless of whether or not they are actually open.</p>
<p>Sensor Status</p>  <p>Supply Sensor 180 F Normal Return Sensor 768 F Shorted Stack Sensor 024 F Open Outdoor Sensor 45 F Normal Header Sensor 180 F Normal</p>	Sensor Fault	<p>The Sensor Status screen shows the status of all sensors. Possible states include:</p> <p>None: Feature requiring this sensor has not been selected. Normal: Sensor is working normally. Shorted: Sensor is shorted or is defective. Open: There is a break in the wiring between the Control and the sensor or the sensor is defective Out of Range: Sensor is defective or is being subjected to electrical noise. Unreliable: Sensor is defective or is being subjected to electrical noise.</p> <p>When a sensor fails “opened” or “shorted” the value is changed to reverse video (background black and value white) “024” or “768” respectively to indicate that there is a fault with the sensor.</p>
<p>Rate Limit</p>  <p>The firing rate is limited by the expected heat rate (DHW plus Zones). Boiler is free to modulate up the the sum of the active heat rates. Each expected heat rate is adjustable under the modulation menu.</p>	Rate Limit	<p>The following messages appear when the firing rate is limited or reduced to help avoid a lockout or save energy.</p> <p>Refer to Hard Lockout section for corrective actions</p> <ul style="list-style-type: none"> - High Stack Temperature Limit - High Supply Temperature Limit - High Differential Temperature Limit <p>The following messages appear as part of normal start and stop sequences:</p> <ul style="list-style-type: none"> - Minimum Modulation (normal start/stop sequence) - Low Fire Hold Rate: Low fire hold rate is a normal start-up rate hold used to help ensure system temperature feedback prior to release to modulation. Low Fire Hold Time may be adjusted. Refer to the “Changing Adjustable Parameters”, Paragraph F, for additional information. - Maximum Expected Heat Rate: Maximum Expected Heat Rate limit is a normal start-up rate hold used to save energy. This limit helps reduce extra cycles and save energy. Boiler is free to modulate up to the sum of the active zones and domestic hot water expected heat rates. Each zone heat rate is adjustable and may be modified under the modulation menu. Refer to the “Changing Adjustable Parameters”, Paragraph F, for additional information.
<p>EMS Status</p>  <p>Modbus Stat (563) on Selected Modbus Rate (581) 535 Selected Modbus Setpoint (562) Not Selected 4-20mA Rate Input Not Selected 4-20 mA Input Setpoint Not Selected</p>	Energy Management System Fault	<p>The Energy Management System (EMS) fault screen provides input fault status. When an input is shown as “Not Selected” it is not required for this application or has not yet been selected. These options are selected under the “Energy Management” Adjust mode menu.</p> <p>Modbus Input Failure If a modbus input is selected and out of range or not present a “535” value is shown reverse video (background black and value white). To fix the problem check the input source and check that the input is properly connected.</p> <p>4-20mA Input Failure Failure status for the 4-20mA input is the same as shown under Sensor Fault.</p>

XII. Troubleshooting (continued)

F. Troubleshooting problems where a Soft Lockout Code is displayed. When a soft lockout occurs, the boiler will shut down, the display will turn red and the “Help” button will “blink”. Select the “blinking” “Help” button to determine the cause of the soft lockout. The boiler will automatically restart once the condition that caused the lockout is corrected.

Soft Lockout Codes Displayed

Lockout Number	Condition	Possible Cause
1 Anti Short Cycle	Minimum time between starts has not been reached. Normal delay used to avoid excessive cycles.	
2 Boiler Safety Limit Open	Boiler Safety Limit wired to terminals J6-1, 2 or 3 OPEN: <ul style="list-style-type: none"> Condensate Trap Float Switch contact open. Thermal Link Switch contact open. Burner Door Thermostat with manual reset contact open. Air Pressure Switch contact open. Auto Reset High Limit contact open. 	<ul style="list-style-type: none"> Loose wiring to limit device. Auto Reset Supply high limit sensor detected temperature in excess of 200°F. Defective Auto Reset Supply High Limit Switch. Plugged Condensate Trap - also check to ensure boiler is level. Thermal Link Switch blown due to temperature rise above 604°F (318°C). Burner Door Thermostat with manual reset contact open due to temperature rise above 500°F (260°C) - check the cause of overheating (burner door insulation, loose mounting, etc.). Air Pressure Switch contact open - check for blocked vent. See possible causes for “Hard Lockout 4”. <p style="text-align: center;">NOTE Block Vent Special Note</p> <p>Before a call for heat the air pressure switch is closed. When there is a call for heat with a blocked vent the air pressure switch will open (due to excessive pressure of the blower against a blocked flue pipe) after the blower starts. The control stops the start sequence and stops the blower. After the blower stops the pressure switch re-closes and the cycle continues. The displays shows the cause of trip for only the time the pressure switch is open.</p>
3 Boiler Safety Limit Open	Boiler Safety Limit, or External Limit wired to terminals J5-1 OPEN: <ul style="list-style-type: none"> Jumper for External Limit wired to terminals 11 and 12 or device connected to it open. Jumper for Flow Switch or device connected to it open. Jumper for Low Gas Pressure Switch or device connected to it open. 	<ul style="list-style-type: none"> See possible causes for “Hard Lockout 4”. Loose wiring to limit device. External Limit defective or jumper not installed. Low Gas Pressure Switch contact open (if installed). Flow switch not installed and jumper missing. No flow or insufficient flow through boiler loop or flow switch defective. If neither yellow or green light is on, check LWCO harness.
7 Return sensor fault	Shorted or open return temperature sensor.	<ul style="list-style-type: none"> Shorted or mis-wired return sensor wiring. Defective return sensor.
8 Supply sensor fault	Shorted or open supply temperature sensor.	<ul style="list-style-type: none"> Shorted or mis-wired supply sensor wiring. Defective supply sensor.
9 DHW sensor fault	Shorted or open Domestic Hot Water (DHW) temperature sensor.	<ul style="list-style-type: none"> Shorted or mis-wired DHW sensor wiring. Defective DHW sensor.
10 Stack sensor fault	Shorted or open flue gas (stack) temperature sensor.	<ul style="list-style-type: none"> Shorted or mis-wired stack sensor wiring. Defective stack sensor.
11 Ignition failure	Model APX425 flame failure after 5 tries to restart.	<ul style="list-style-type: none"> No gas pressure. Gas pressure under minimum value shown on rating plate. Gas line not completely purged of air. Defective Electrode. Loose burner ground connection. Defective Ignition Cable. Defective gas valve (check for 24 Vac at harness during trial for ignition before replacing valve). Air-fuel mixture out of adjustment - consult factory.
13 Flame rod shorted to ground	Flame rod shorted to ground	<ul style="list-style-type: none"> Shorted or mis-wired flame rod wiring. Defective flame rod.
14 ΔT inlet/outlet high	Temperature rise between supply and return is too high.	<ul style="list-style-type: none"> Inadequate boiler water flow. Verify that circulator is operating and that circulator and piping are sized per Section VI of this manual.
15 Return temp higher than supply	The Control is reading a return sensor temperature higher than the supply sensor temperature. Condition must be present for at least 75 seconds for this error code to appear.	<ul style="list-style-type: none"> Flow through boiler reversed. Verify correct piping and circulator orientation. No boiler water flow. Verify that system is purged of air and that appropriate valves are open. Sensor wiring reversed. Supply or return sensor defective.
16 Supply temp has risen too quickly	Supply water temperature has risen too quickly.	<ul style="list-style-type: none"> See possible causes for “Hard Lockout 4”. Inadequate boiler water flow. Verify that circulator is operating and that circulator and piping are sized per Section VI of this manual.
17 Blower speed not proved	Normal waiting for blower speed to match purge and light-off setpoint.	

XII. Troubleshooting (continued)

G. Troubleshooting problems where a Hard Lockout Code is displayed. When a hard lockout occurs, the boiler will shut down, the display will turn red and the “Help” button will “blink”. Select the “blinking” “Help” button to determine the cause of the Hard Lockout. Once the condition that caused the lockout is corrected, the boiler will need to be manually reset using the Reset button on the “Active Fault” display or located on the R7910 Control.

Alarm Output Contact

The Control includes an alarm output contact located on Control terminals J6 - 7 & 8. The alarm contact closes when the Control goes into a manual reset Hard Lockout. The list of Hard Lockouts is shown below.

Hard Lockout Codes Displayed

Lockout Number	Condition	Possible Cause
4 Supply high limit	R7910 supply sensor detected temperatures in excess of 210°F.	<ul style="list-style-type: none"> Heating load at time of error was far below the minimum firing rate of the boiler. Defective system circulator or no flow in primary loop. Defective boiler circulator, no flow or insufficient flow in boiler loop, or defective flow switch. Control system miswired so that the boiler operation is permitted when no zones are calling.
5 DHW high limit	R7910 DHW sensor detected temperatures in excess of Setpoint.	<ul style="list-style-type: none"> DHW load at time of error was far below the minimum firing rate of the boiler. Control system miswired so that boiler operation is permitted when no DHW are calling.
6 Stack High limit	R7910 Flue gas (Stack) sensor detected temperatures in excess of 204°F (95.6°C).	<ul style="list-style-type: none"> Heat exchanger needs to be cleaned. Boiler over-fired. Air-fuel mixture out of adjustment - consult factory.
12 Flame detected out of sequence	A flame signal was present when there should be no flame.	<ul style="list-style-type: none"> Defective gas valve - make sure inlet pressure is below maximum on rating plate before replacing valve.
18 Light off rate proving failed	Blower is not running at Light-off rate when it should or blower speed signal not being detected by R7910.	<ul style="list-style-type: none"> Loose connection in 120 VAC blower wiring. Loose or miswired blower speed harness. Defective blower
19 Purge rate proving failed	Blower is not running at Purge rate when it should or blower speed signal not being detected by R7910.	<ul style="list-style-type: none"> Loose connection in 120 VAC blower wiring. Loose or miswired blower speed harness. Defective blower
20 Invalid Safety Parameters	Unacceptable R7910 control Safety related parameter detected.	Parameters change was invalid. Check parameter selection and reset Control. Contact factory if problem persists.
21 Invalid Modulation Parameter	Unacceptable R7910 control Modulation related parameter detected.	Reset the control.
22 Safety data verification needed	Safety related parameter change has been detected and a verification has not been completed.	Safety related R7910 control parameter has been changed and verification has not been performed.
23 24VAC voltage low/high	R7910 control 24Vac control power is high or low.	<ul style="list-style-type: none"> Loose connection in 24Vac VAC power wiring. Loose or miswired 24Vac harness. Miswired wiring harness causing power supply short to ground. Defective transformer. Transformer frequency, voltage and VA do not meet specifications.
24 Fuel Valve Error	Power detected at fuel valve output when fuel valve should be off.	<ul style="list-style-type: none"> Loose or defective gas valve harness. Check electrical connections. Defective gas valve (check for 24 Vac at harness during trial for ignition before replacing valve).
25 Hardware Fault	Internal control failure.	<ul style="list-style-type: none"> Reset the control. If problem reoccurs, replace the Control.
26 Internal Fault	Internal control failure.	<ul style="list-style-type: none"> Reset the control. If problem reoccurs, replace the Control.
27 Ignition failure	Models APX525, APX625, APX725 and APX825: Flame failure after 1 try to restart.	<ul style="list-style-type: none"> No gas pressure. Gas pressure under minimum value shown on rating plate. Gas line not completely purged of air. Defective Electrode. Loose burner ground connection. Defective Ignition Cable. Defective gas valve (check for 24 Vac at harness during trial for ignition before replacing valve). Air-fuel mixture out of adjustment - consult factory.

XIII. Repair Parts

All Apex Repair Parts may be obtained through your local authorized Thermal Solutions representatives or outlets. Should you require assistance in locating a Thermal Solutions representative or outlet in your area, or have questions regarding the availability of Thermal Solutions products or repair parts, please contact Thermal Solutions Customer Service at (717) 239-7642 or Fax (877) 501-5212.

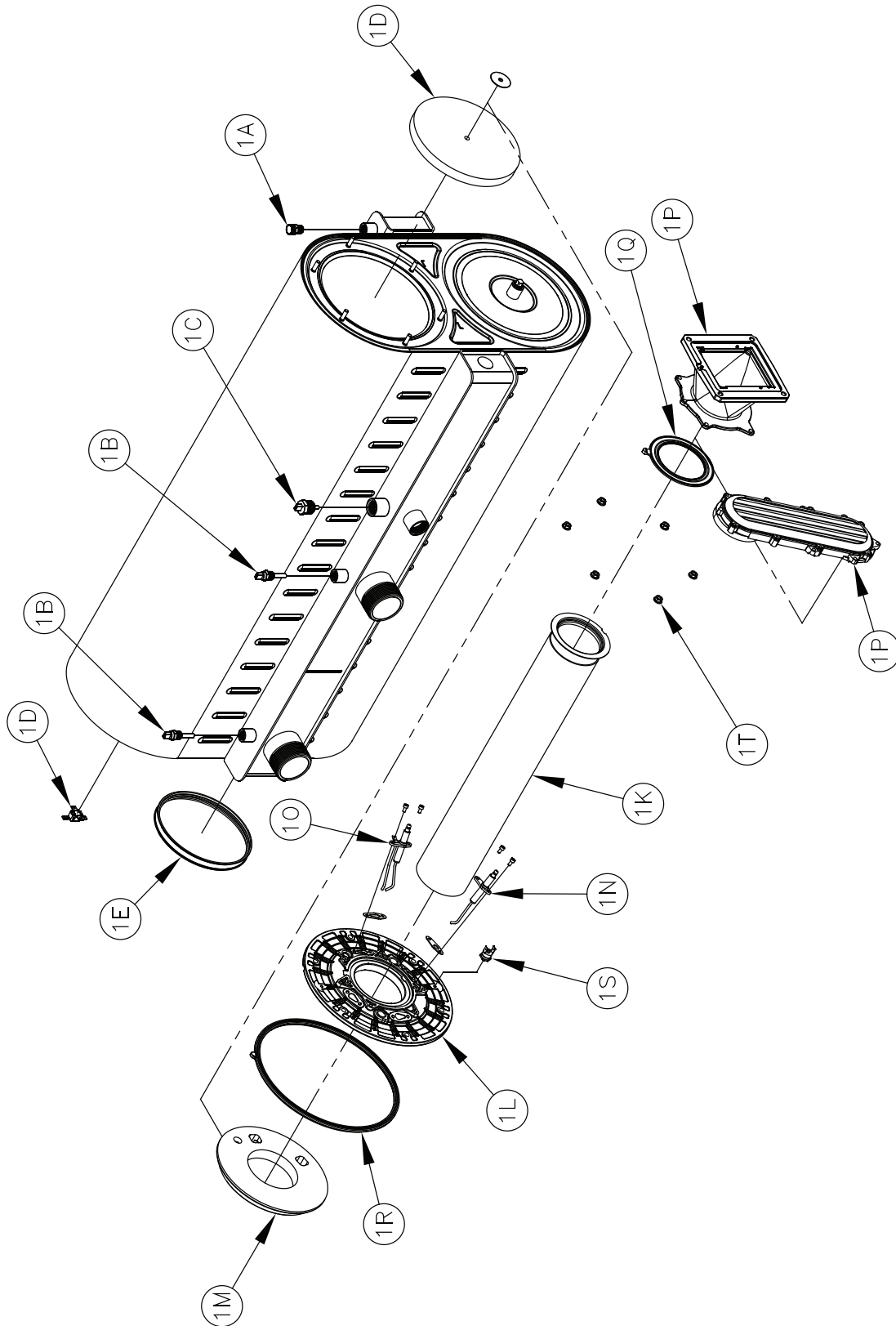

XIII. Repair Parts (continued)

Heat Exchanger Components						
Key No.	Description	Part Number				
		APX425	APX525	APX625	APX725	APX825
1A	Air Vent Valve	101586-01				
1B	Supply/Return Water Temperature Sensor (2 per boiler)	101685-01				
1C	High Limit Water Temperature Sensor	101653-01				
1D1	Replacement Rear Insulation Disc Kit (includes insulation, disc, thermal link switch and instructions) (Warning: Contains RCF)	104998-01				
1D2	Replacement Rear Insulation Disc Kit	105651-01				
1E	Flue Exit Gasket Replacement Kit (includes gasket and dielectric grease)	104501-01	104502-01			
1G	Temperature and Pressure Gauge (not shown)	100282-01	103470-02			
1H	Safety Relief Valve (not shown)	50 PSI: 103837-01	60 PSI: 81660375			
	Alternate Safety Relief Valve Kit (not shown, includes safety relief valve and temperature and pressure gage)	80 PSI: 104200-01 100 PSI: 104201-01				
1J	Boiler Drain Valve, 3/4 in. NPT (not shown)	806603061				

Burner Components						
Key No.	Description	Part Number				
		APX425	APX525	APX625	APX725	APX825
1K	Replacement Burner Kit (includes burner, burner head seal and hardware)	104988-01	104989-01	104990-01		104991-01
1L	Replacement Burner Door Kit (includes door, burner door inner and outer seals, gaskets for sensor and ignitor, insulation and thermostat; does not include igniter or flame sensor)	104992-01			104993-01	
1M	Burner Door Insulation Kit (Warning: Contains RCF)	105650-01			105674-01	
1N	Replacement Flame Sensor Kit (includes gasket and hardware)	103339-01	105798-01	103310-01		
1O	Replacement Igniter Kit (includes gasket and hardware)	103005-01	103005-02	103308-01		
1P	Replacement Gas/Air Duct Kit (includes duct gaskets and hardware)	104994-01	104995-01	104996-01		
1Q	Burner Gasket	102739-01			104986-01	
1R	Burner Door Outer Seal	101730-01			104985-01	
1S	Burner Door Thermostat with Manual Reset	104569-01				
1T	Burner Door Hex Flange Nut, M6 x 1.0 mm (6 per boiler)	101724-01				

XIII. Repair Parts (continued)

APX425 and APX525

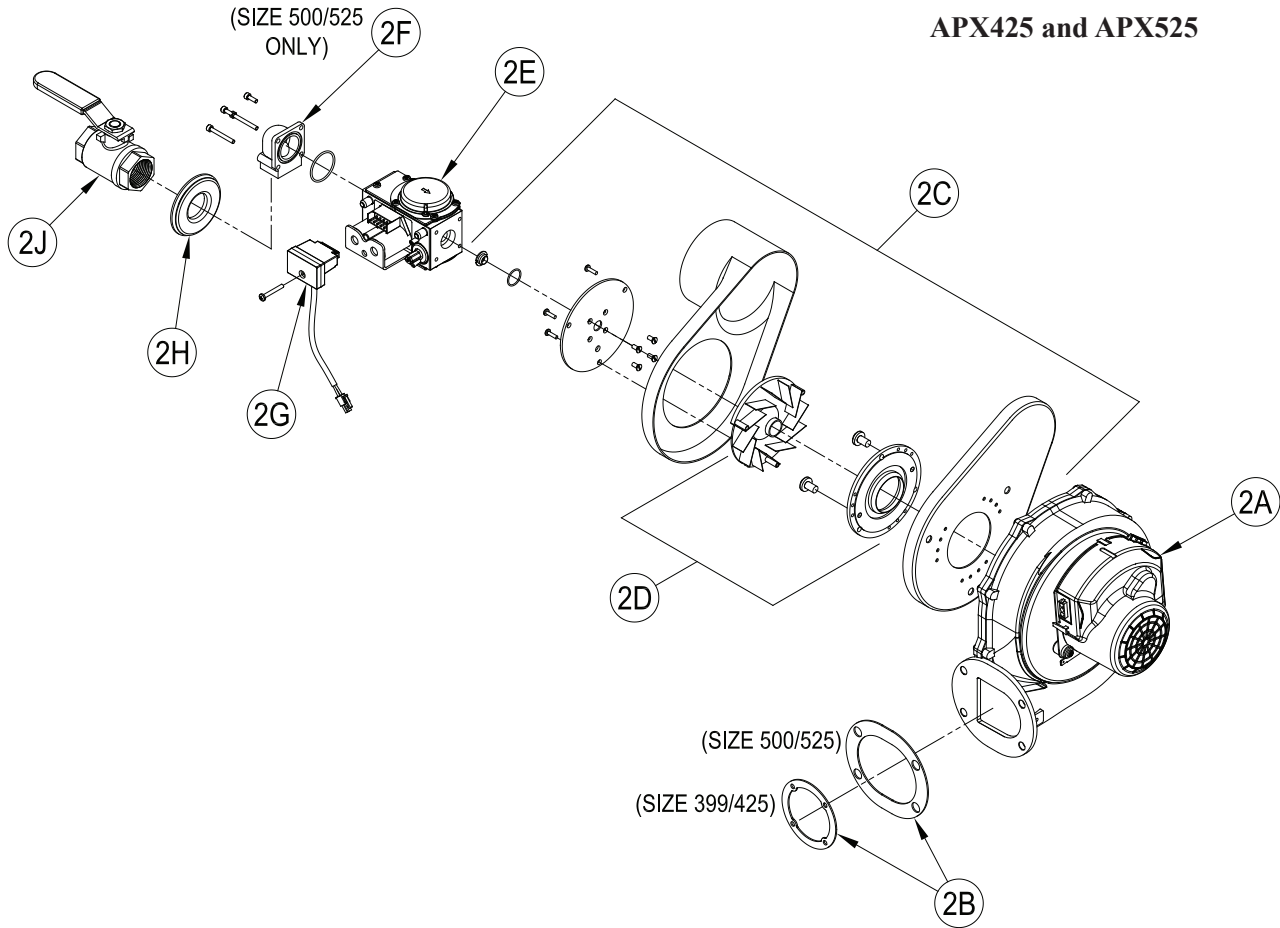

Blower / Gas Train Components						
Key No.	Description	Part Number				
		APX425	APX525	APX625	APX725	APX825
2A	Replacement Blower Kit (includes blower, blower outlet gasket and hardware)	104999-01	104999-02	104999-03		
2B	Blower Outlet Gasket	101345-01	102614-01	103263-01		
2C	Blower Inlet Assembly (includes gas orifice, injector flange, inlet shroud (425 and 525 only), swirl plate, blower adapter plate, and mounting hardware)	101704-04	101704-05	Natural Gas: 105001-01 LP Gas: 105000-01	Natural Gas: 105001-02 LP Gas: 105000-02	103223-01
2D	Blower Inlet Replacement Kit (includes swirl plate, blower adapter plate, and mounting hardware)	104620-04	104620-05	N/A	N/A	N/A
2E	Replacement Gas Valve Kit (includes one gas valve and o-rings)	105004-01	105004-02	Natural Gas: 105004-04 LP Gas: 105004-03		
2F	Gas Valve Flange Kit (includes one 90° gas valve flange, o-ring, and hardware)	N/A	102972-03			
2G	Gas Valve Wire Harness (includes harness with plug and M4 x 30 mm screw)	102971-01		Natural Gas: 103225-01 LP Gas: 103300-01		
2H	Gas Line Rubber Grommet	3/4 in. NPT: 101638-01		1 in. NPT: 103252-01		
2J	Gas Shutoff Valve	3/4 in. NPT: 101615-01		1 in. NPT: 816SOL0015		

XIII. Repair Parts (continued)

APX625, APX725 and APX825
(APX825 shown)

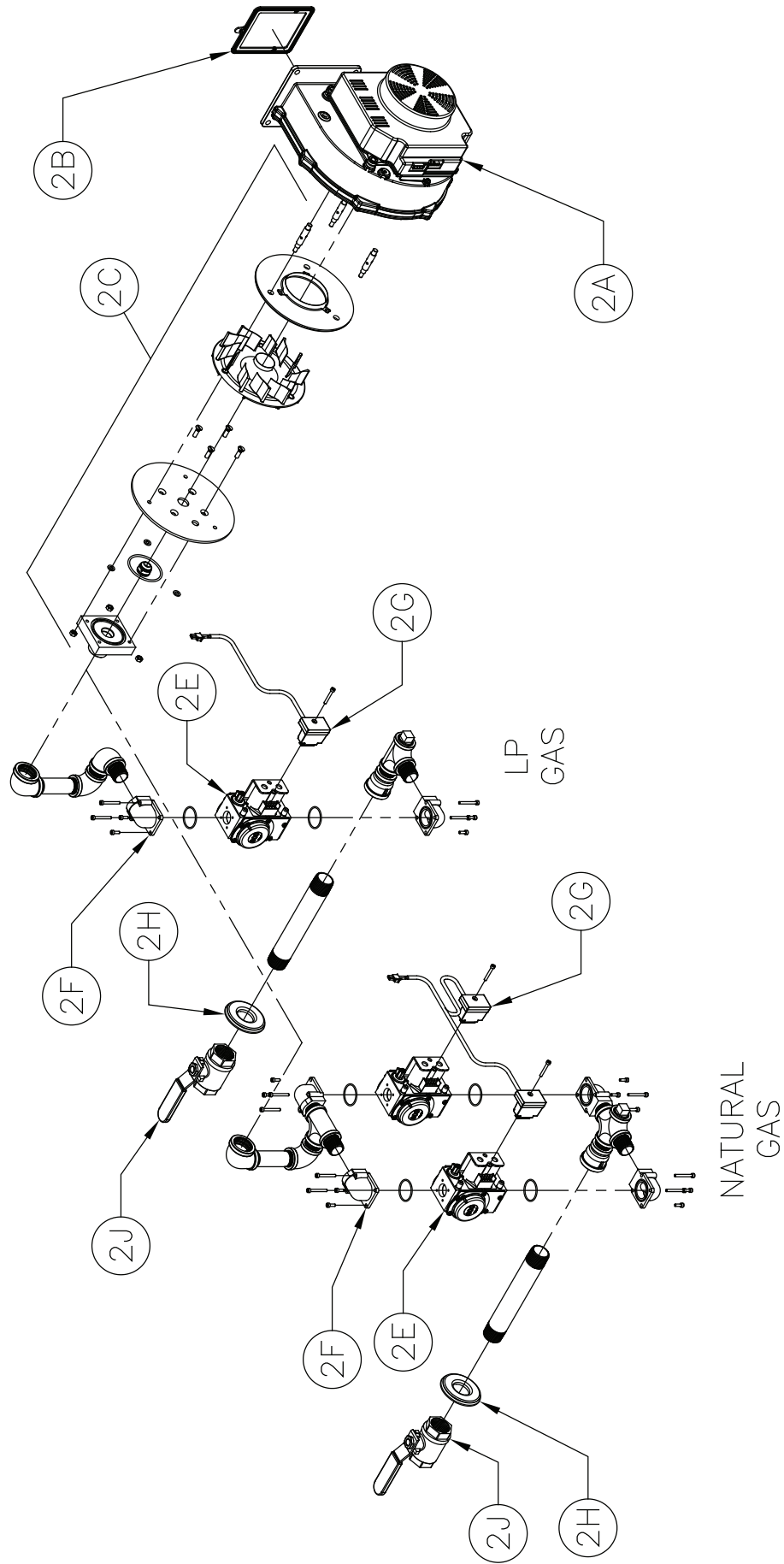

XIII. Repair Parts (continued)

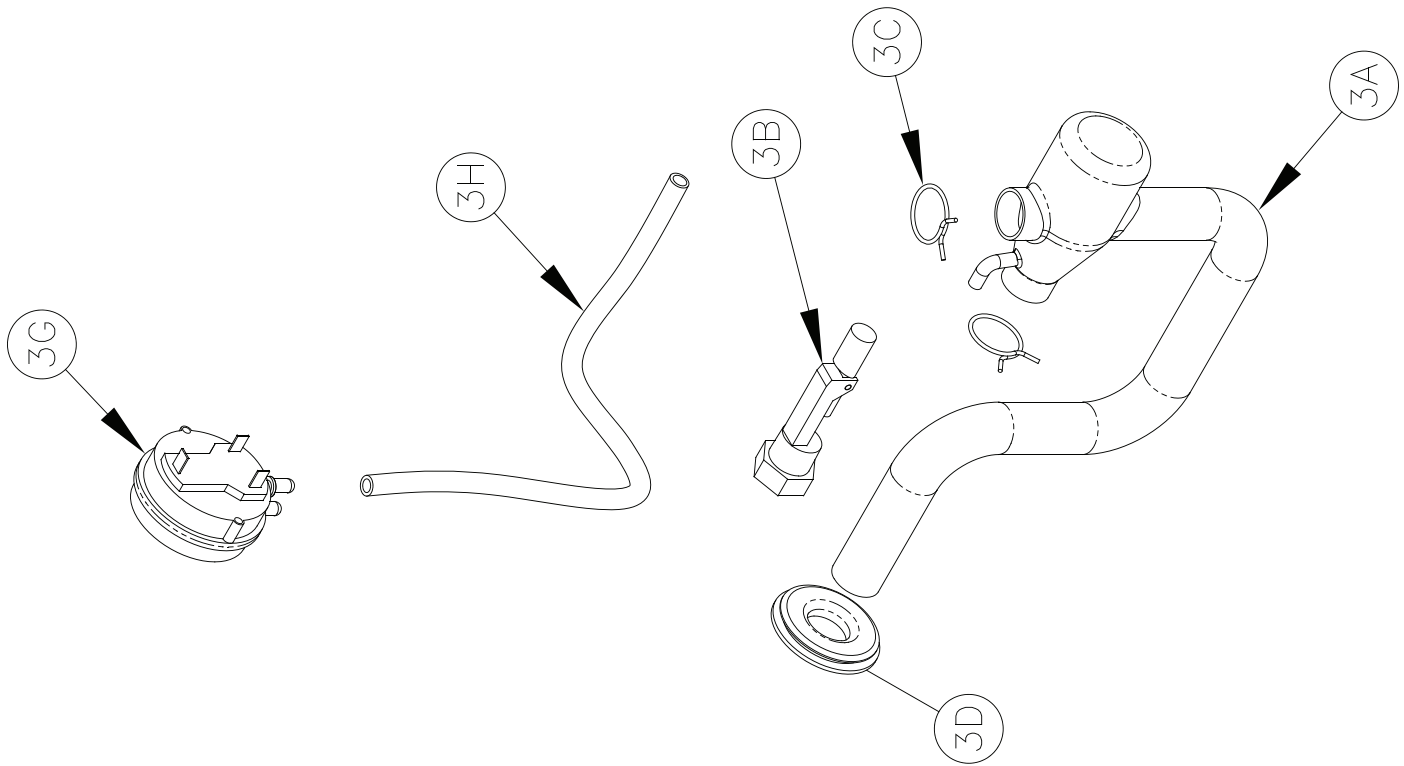

Condensate Trap and Related Components						
Key No.	Description	Part Number				
		APX425	APX525	APX625	APX725	APX825
3A	Replacement Condensate Trap Kit (includes trap, float switch, grommet, coupling, and clamps)	104704-01		105006-01		104704-01
3B	Replacement Condensate Float Switch Kit (includes float switch and clamp)	105005-01				
3C	Spring Hose Clamp, 15/16 in. OD hose	101632-01				
3D	Rubber Grommet, Condensate Trap	101595-01				
3E	Condensate Neutralizer Kit (not shown, includes limestone chips)	101867-01				
3F	Limestone Chips, 2 lb. bag (not shown)	101873-01				
3G	Air Pressure Switch	104426-01				
3H	Air Pressure Switch Tubing, Silicone, 3/16 in. ID x 0.07 in. Wall Thickness	13.5 in. 7016041	22 in. 102770-01	24 in. 104658-01		28 in. 103257-01

XIII. Repair Parts (continued)

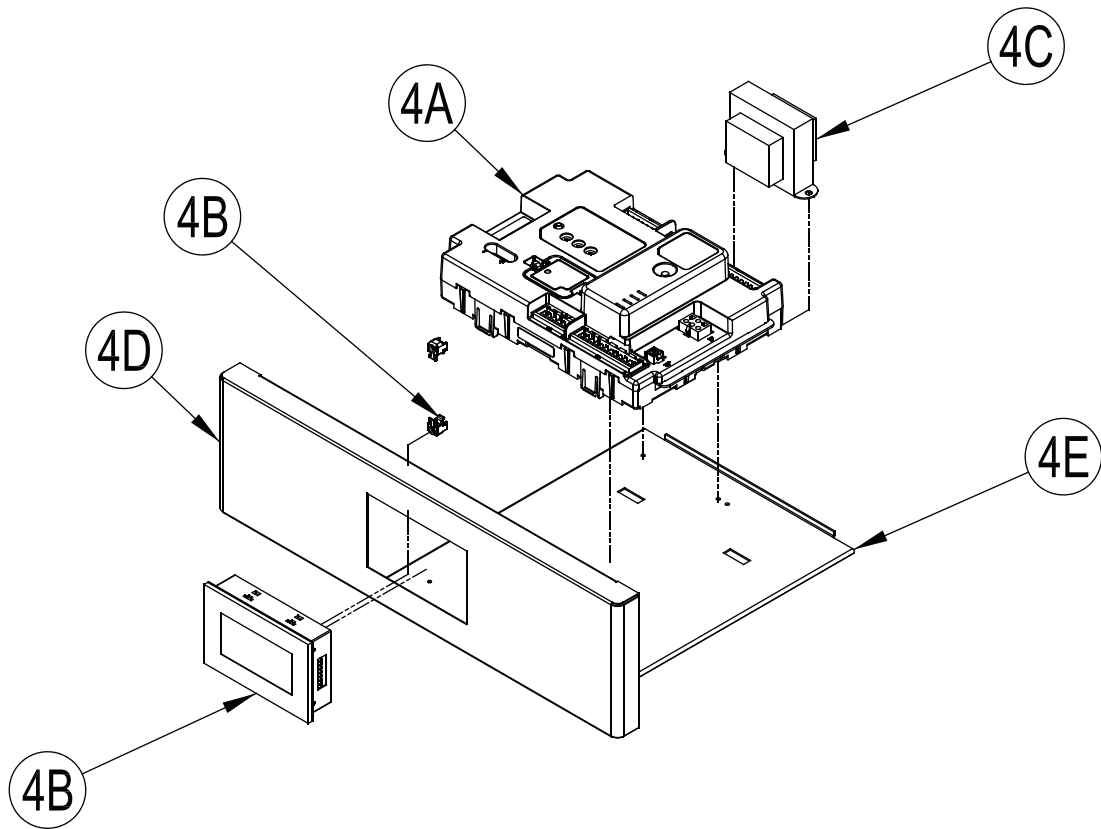

Control Components						
Key No.	Description	Part Number				
		APX425	APX525	APX625	APX725	APX825
4A	Replacement R7910 Control Kit (programmed)	106192-01	106192-02	Natural Gas: 106192-03 LP Gas: 106192-04		106192-02
4B	Replacement Display Kit (programmed, includes mounting hardware)	106217-01				
4C	Transformer (or, Kit)	106034-01		103193-01		
4D	Upper Front panel	102778-01				
4E	Control Slide Out Tray	103336-01				

122 XIII. Repair Parts (continued)

APX425 and APX525

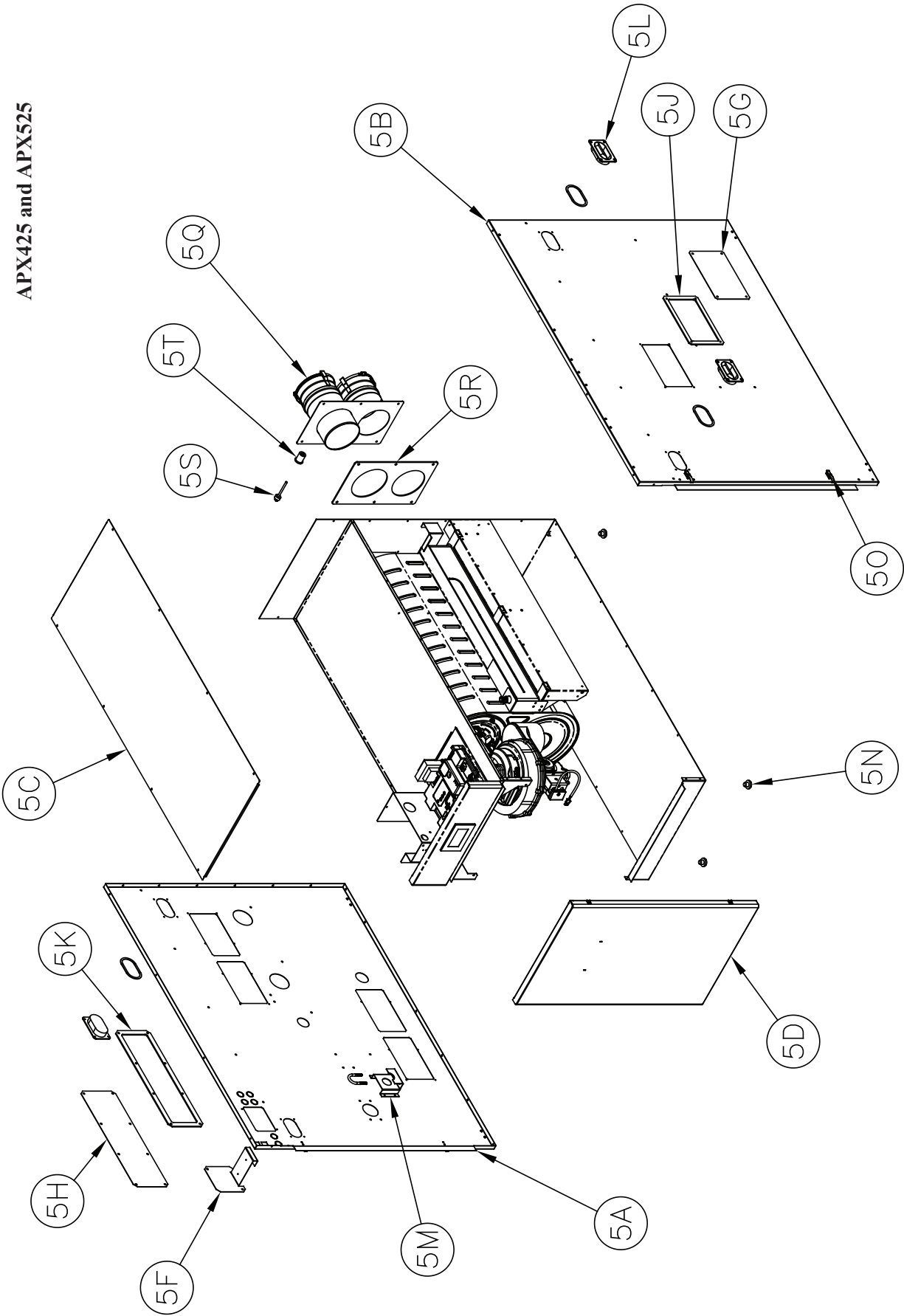

XIII. Repair Parts (continued)

Sheet Metal, APX425 and APX525			
Key No.	Description	Part Number	
		APX425	APX525
5A	Replacement Left Side Panel Kit (includes labels, access panels, grommets and header gaskets)	105017-01	105017-02
5B	Replacement Right Side Panel Kit (includes labels, access panels and gaskets)	105018-01	105018-02
5C	Replacement Top Panel Kit (includes labels)	105019-01	105019-02
5D	Replacement Front Door Kit (includes labels)	105016-01	105016-02
5E	Replacement Rear Panel Kit (includes access panel and gaskets)	N/A	
5F	High Voltage Terminal Bracket	102780-01	
5G	Replacement Access Panel Kit, 5 in. x 8 in. (includes gasket)	105010-01	
5H	Replacement Access Panel Kit, 5 in. x 16 in. (includes gasket)	N/A	105011-01
5J	Access Panel Gasket, 5 in. x 8 in.	102877-01	
5K	Access Panel Gasket, 5 in. x 16 in.	N/A	102613-01
5L	Replacement Handle Kit (includes gasket)	105015-01	
5M	Gas Train Bracket	N/A	102611-01
5N	Nylon Glide Replacement Kit (includes 6 glides)	105014-01	
5O	Replacement Door Latch Kit (includes rivets)	105012-01	
5P	Replacement Stacking Bracket Kit (not shown, includes 4 brackets and hardware)	105022-01	
5Q	CPVC/PVC Vent System Connector Replacement Kit (includes gasket and flue temperature sensor cap)	4 in. x 4 in. 105021-01	
5R	CPVC/PVC Vent System Connector Gasket	4 in. x 4 in. 102185-02	
5S	Flue Temperature Sensor	101687-01	
5T	Replacement Flue Temperature Sensor Cap Kit (includes cap, Molykot III grease and instructions)	105318-01	

XIII. Repair Parts (continued)

APX625, APX725 and APX825

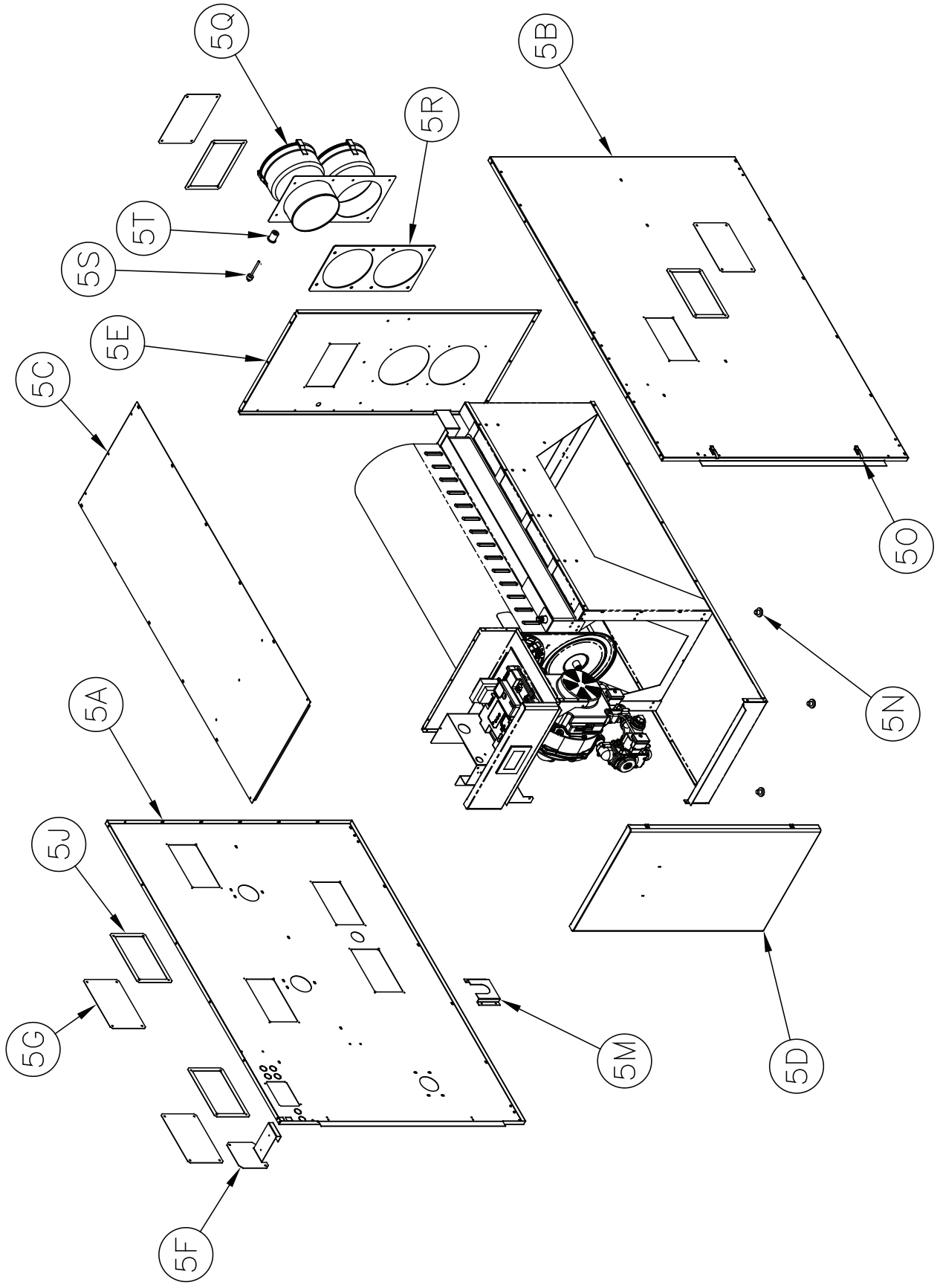

XIII. Repair Parts (continued)

Sheet Metal, APX625, APX725 and APX825				
Key No.	Description	Part Number		
		APX625	APX725	APX825
5A	Replacement Left Side Panel Kit (includes labels, access panels, grommets and header gaskets)	105017-03		105017-04
5B	Replacement Right Side Panel Kit (includes labels, access panels and gaskets)	105018-03		105018-04
5C	Replacement Top Panel Kit (includes labels)	105019-03		105019-04
5D	Replacement Front Door Kit (includes labels)	105016-02		
5E	Replacement Rear Panel Kit (includes access panel and gaskets)	105020-01	105020-02	
5F	High Voltage Terminal Bracket	102780-01		
5G	Replacement Access Panel Kit, 5 in. x 8 in. (includes gasket)	105010-01		
5H	Replacement Access Panel Kit, 5 in. x 16 in. (includes gasket)	N/A		
5J	Access Panel Gasket, 5 in. x 8 in.	102877-01		
5K	Access Panel Gasket 5 in. x 16 in.	N/A		
5L	Replacement Handle Kit (includes gasket)	N/A		
5M	Gas Train Bracket	103240-01		
5N	Nylon Glide Replacement Kit (includes 6 glides)	105014-01		
5O	Replacement Door Latch Kit (includes rivets)	105012-01		
5P	Replacement Stacking Bracket Kit (not shown, includes 4 brackets and hardware)	105022-01		
5Q	CPVC/PVC Vent System Connector Replacement Kit (includes gasket and flue temperature sensor cap)	6 in. x 6 in. 105021-02		
5R	CPVC/PVC Vent System Connector Gasket	6 in. x 6 in. 103248-01		
5S	Flue Temperature Sensor	101687-01		
5T	Replacement Flue Temperature Sensor Cap Kit (includes cap, Molykot III grease and instructions)	105318-01		

XIII. Repair Parts (continued)

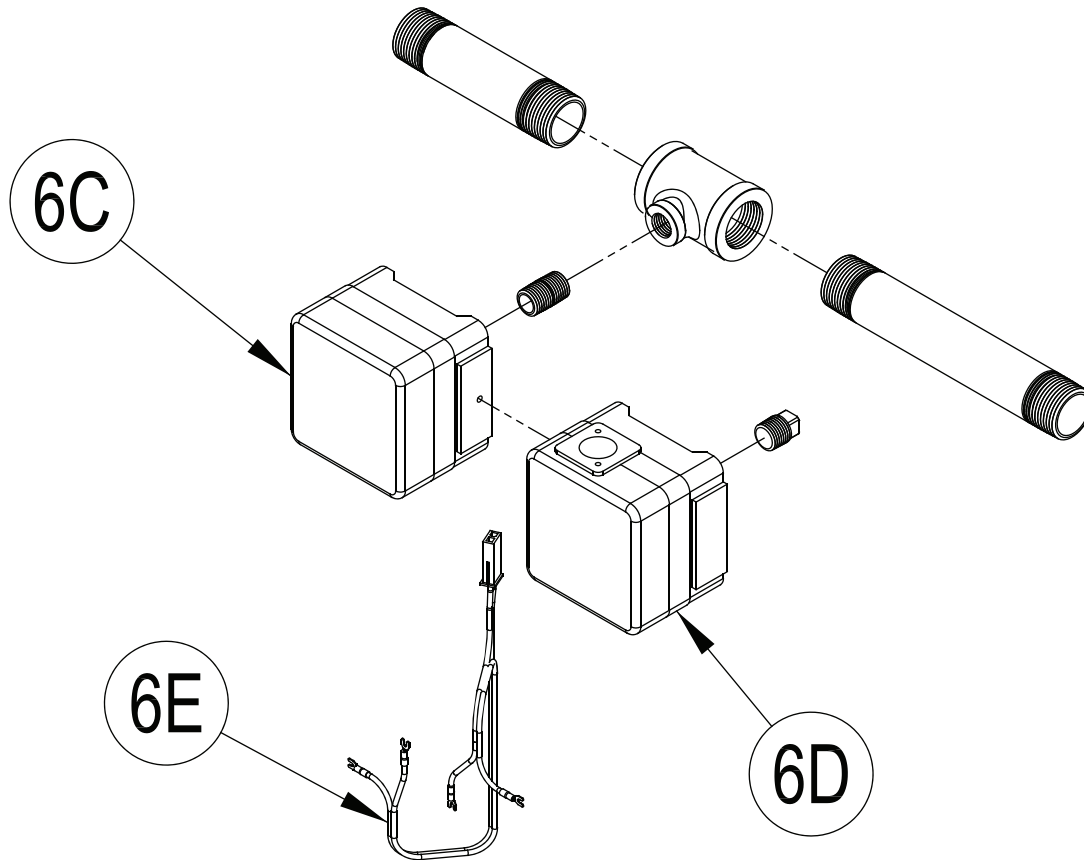

Additional Components						
Key No.	Description	Part Number				
		APX425	APX525	APX625	APX725	APX825
6A	CSD-1 Kit (not shown, includes manual reset high limit, immersion well, gas pressure switches, and hardware)			104780-01		
6B	Gas Pressure Switch Assembly	N/A		102670-01		
6C	Low Gas Pressure Switch	N/A		102702-01		
6D	High Gas Pressure Switch	N/A		102703-01		
6E	Gas Pressure Switch Wire Harness	N/A		102704-01		
6F	Flow Switch Kit (not shown, includes switch and paddles)			104927-01		
6G	Flow Switch Repair Paddle Kit (not shown, includes paddles and hardware)			104926-01		
6H	Outdoor Temperature Sensor (not shown)			102946-01		
6J	Header Sensor for Direct Immersion, 1/2 in. NPT (not shown)			101935-01		
6K	Header Sensor Kit (not shown, includes mounting hardware)			103104-01		
6L	30 in. Long Schedule 40 CPVC Pipe (not shown)	4 in. 102193-02			6 in. 103267-01	
6M	Schedule 80 CPVC 90° Elbow (not shown)	4 in. 102192-02			6 in. 103268-01	
6N	Rodent Screen (not shown)	4 in. 102191-02			6 in. 102191-03	

XIII. Repair Parts (continued)

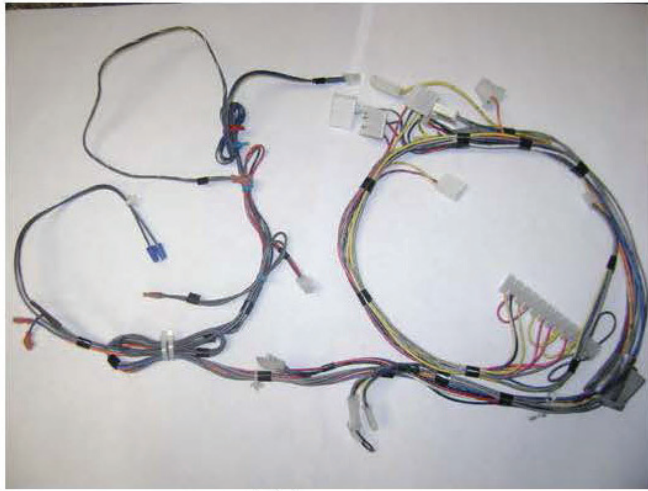

10A

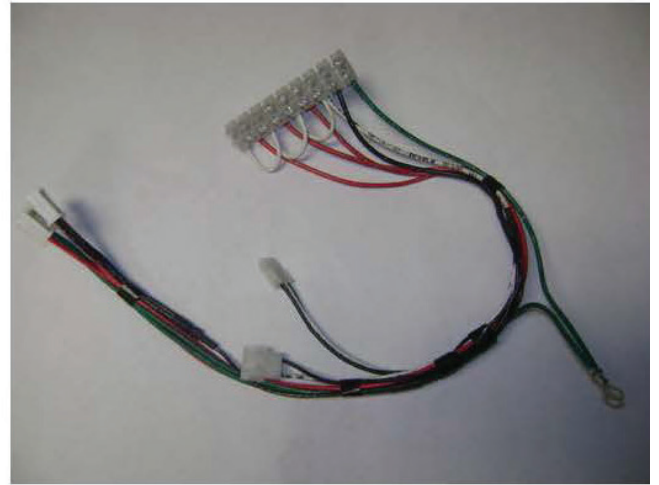

10B



10C

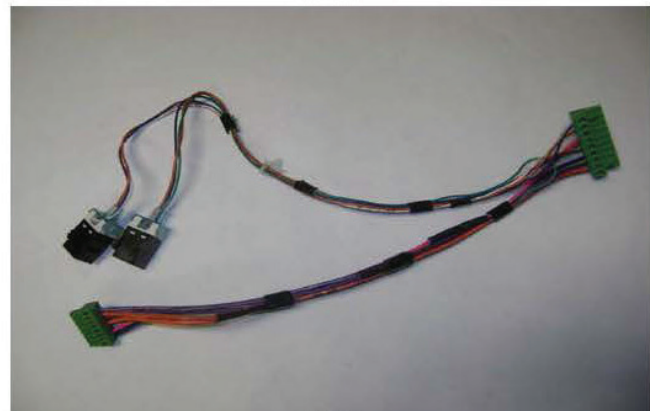

10D



10E



10F

		Wiring Harnesses				
Key No.	Description	Part Number				
		APX425	APX525	APX625	APX725	APX825
---	Complete Wiring Harness (includes 10A, 10B, 10C & 10D)			102701-03		
10A	Main (Low Voltage) Harness			103009-03		
10B	High Voltage Harness			103010-02		
10C	Blower Power Harness			103012-01		
10D	Communication Harness			103011-01		
10E	Igniter Harness			105752-01		
10F	Wiring Harness, Thermal Link and Burner Door Thermostat			104574-01		

Appendix A - Figures

Figure Number	Page Number	Description
Section I - Product Description, Specifications & Dimensional Data		
Figure 1A	6	Apex - Model APX425
Figure 1B	7	Apex - Model APX525
Figure 1C	8	Apex - Models APX625 and APX725
Figure 1D	9	Apex - Model APX825
Section III - Pre-Installation and Boiler Mounting		
Figure 2	12	Clearances To Combustible and Non-combustible Material
Figure 3	14	Stacking Boiler Attachment Bracket Placement
Section IV - Venting		
Figure 4	17	Location of Vent Terminal Relative to Windows, Doors, Grades, Overhangs, Meters and Forced Air Inlets - Two-Pipe System Vent Terminal (Shown), Two-Pipe System Air Intake Terminal (Not Shown)
Figure 5A	18	Direct Vent - Sidewall Tee Terminations
Figure 5B	19	Direct Vent - Sidewall Elbow Terminations, Size 625 through 825 only
Figure 6A	19	Direct Vent - Optional Vent Sidewall Snorkel Termination
Figure 6B	19	Direct Vent - Optional Vent & Combustion Air Sidewall Snorkel Terminations
Figure 7	20	Direct Vent - Vertical Terminations
Figure 8	20	Direct Vent - Vertical Terminations w/ Sloped Roof
Figure 9	22	Field Installation of CPVC/PVC Two-Pipe Vent System Connector with Factory Installed Flue Temperature Sensor and Sensor Cap
Figure 10	23	Near-Boiler Vent/Combustion Air Piping
Figure 11	24	CPVC/PVC Expansion Loop and Offset
Figure 12	24	Wall Penetration Clearances for PVC Vent Pipe
Figure 13	25	Rodent Screen Installation
Figure 14	28	Vent System Field Modification to Install PVC to PP Adapter (M&G/DuraVent Shown)
Figure 15	29	Flexible Vent in Masonry Chimney with Separate Combustion Air Intake
Figure 16	30	Field Installation of Two-Pipe Vent System Adapter for Stainless Steel
Figure 17	34	Multiple Boiler Direct Vent Termination
Section V - Condensate Disposal		
Figure 18	36	Condensate Trap and Drain Line
Section VI - Water Piping and Trim		
Figure 19A	37	Factory Supplied Piping & Trim Installation - APX425 and APX525
Figure 19B	38	Factory Supplied Piping & Trim Installation - APX625 and APX725
Figure 19C	39	Factory Supplied Piping & Trim Installation - APX825
Figure 20	45	Near Boiler Piping - Heating Only
Figure 21	46	Near Boiler Piping - Heating Plus Indirect Water Heater
Figure 22A	47	Isolation of the Boiler From Oxygenated Water with A Plate Heat Exchanger (IWH Piped as Part of Boiler Piping)
Figure 22B	48	Isolation of the Boiler From Oxygenated Water with A Plate Heat Exchanger (IWH Piped Off System Header)
Figure 23A	49	Multiple Boiler Water Piping w/Domestic Hot Water Heater (Page 1 of 2)
Figure 23B	50	Multiple Boiler Water Piping w/Domestic Hot Water Heater (Page 2 of 2)

Appendix A - Figures (continued)

Figure Number	Page Number	Description
Section VII - Gas Piping		
Figure 24	53	Recommended Gas Piping
Figure 25	54	Gas Inlet Pressure Tap and Pressure Switch Location
Section VIII - Electrical		
Figure 26	57	Ladder Diagram
Figure 27	58 & 59	Wiring Connections Diagram
Figure 28A	60	Modified Wiring For DHW Priority When Using Low Flow Circulator Piped Off System Header - Heating (with Central Heating Circulators) Plus Alternately Piped Indirect Water Heater
Figure 28B	61	DHW Priority/Circulators (with Zone Panel) Piped Off System Header Wiring Schematic for Heating Zone Circulators
Figure 28C	62	Modified Wiring For DHW Priority When Using Low Flow Circulator Piped Off System Header - Heating (with Central Heating Zone Valves) Plus Alternately Piped Indirect Water Heater
Figure 29A	63	Multiple Boiler Wiring Diagram, Internal R7910 Multiple Boiler Control Sequencer (Three Boilers Shown, Typical Connections for up to Eight Boilers)
Figure 29B	64	Boiler-to-Boiler Communication (with Zone Control Circulator Panel)
Figure 30A	65	Multiple Boiler Wiring Diagram w/Tekmar 265 Control
Figure 30B	66	Multiple Boiler Wiring Diagram w/Tekmar 264 Control
Figure 31	67	Recommended Direct Immersion Header Sensor Installation Detail
Figure 32	67	Alternate "Immersion" type Header Sensor Installation Detail
Figure 33	68	RJ45 Splitter Installation Detail
Section IX- System Start-Up		
Figure 34	70	Operating Instructions
Figure 35	72	Burner Flame
Figure 36	72	Gas Valve Detail
Section X - Operation		
Figure 37	82	Home Screen Details
Figure 38	82	Screen Navigation
Figure 39	83	Status Screen Overview
Figure 40	83	Boiler Status Screen Definitions
Figure 41	87	Adjust Mode Screens
Figure 42	90	Four Zone House (with Zone Control Connected)
Figure 43	90	Expected Heat Rate Adjustment (with Zone Control Connected)
Figure 44	101	Outdoor Reset Curve
Section XI - Service and Maintenance		
Figure 45	108	Igniter Electrode Gap
Figure 46	109	Condensate Overflow Switch Orientation
Section XII - Troubleshooting		
Figure 43	111	Help Menu
Section XIII - Repair Parts		
N/A	Pages 116 through 127	

Appendix B - Tables

Table Number	Page Number	Description
Section I - Product Description, Specifications & Dimensional Data		
Table 1A	5	Specifications
Table 1B	5	Dimensions (See Figures 1A, 1B, 1C and 1D)
Table 2	10	Ratings
Section III - Pre-Installation and Boiler Mounting		
Table 3	13	Apex Boiler Model Stacking Combinations
Section IV - Venting		
Table 4	16	Vent/Combustion Air System Options
Table 5	16	Vent/Combustion Air Pipe Length – Two-Pipe Direct Vent System Options CPVC/PVC Polypropylene (PP) or Polypropylene (PP)/PVC Stainless Steel/PVC or Galvanized Steel
Table 6A	16	Vent System and Combustion Air System Components Equivalent Length vs. Component Nominal Diameter
Table 6B	18	Vent Combustion Air Equivalent Length Calculation Work sheet
Table 7A	21	CPVC/PVC Vent & Air Intake Components Included With Boiler
Table 7B	21	CPVC/PVC Vent & Air Intake Components (Installer Provided) required for Optional Horizontal (Snorkel) Termination
Table 7C	22	CPVC/PVC Vent & Air Intake Components (Installer Provided) required for Optional Vertical (Roof) Termination
Table 8	24	Expansion Loop Lengths
Table 9	26	Listed Polypropylene Vent System Manufacturers
Table 10A	27	Listed Polypropylene Pipe, Fittings and Terminations - M&G/DuraVent
Table 10B	27	Listed Polypropylene Pipe, Fittings and Terminations - Centrotherm Eco
Table 11A	30	Thermal Solutions Vent System Components (Stainless Steel)
Table 11B	30	Alternate Vent Systems and Vent Components (Stainless Steel)
Section VI - Water Piping and Trim		
Table 11C	35	Maximum Condensate Flow
Table 12	40	Flow Range Requirement Through Boiler
Table 13A	42	Recommended Taco Circulators for 50 ft. Equivalent ft. Near Boiler Piping [Approximately 20 ft. Straight Pipe, (4) 90° Elbows, and (2) Full Port Ball Valves]
Table 13B	42	Recommended Grundfos Circulators for 50 Equivalent ft. Near Boiler Piping [Approximately 20 ft. Straight Pipe, (4) 90° Elbows, and (2) Full Port Ball Valves]
Table 14	43	Fitting & Valve Equivalent Length
Table 15	47	Multiple Boiler Water Manifold Sizing
Section VII - Gas Piping		
Table 16A	51	Maximum Capacity of Schedule 40 Black Pipe in CFH* (Natural Gas) For Gas Pressures of 13.8 in. w.c. or Less
Table 16B	52	Maximum Capacity of Schedule 40 Black Pipe in CFH* (LP Gas) For Gas Pressures of 0.5 psig or Less
Table 17	52	Equivalent Length of Standard Pipe Fittings & Valves
Table 18	53	Specific Gravity Correction Factors
Table 19	53	Min./Max. Pressure Ratings

Appendix B - Tables (continued)

Table Number	Page Number	Description
Section VIII - Electrical		
Table 20	56	Boiler Current Draw
Section IX - System Start-Up		
Table 21	71	Typical Combustion Settings, Natural Gas
Table 22	72	Typical Combustion Settings, LP Gas
Table 23	74	Approximate Number of Clockwise Throttle Screw Turns for LP Conversion
Table 24A	75	Approximate Throttle Screw Adjustment Values from Fully Closed Position, Natural Gas
Table 24B	75	Approximate Throttle Screw Adjustment Values from Fully Closed Position, LP Gas
Section X - Operation		
Table 25	78	Order of Priority
Table 26	79	Frost Protection
Table 27	81	Boiler Sequence of Operation
Table 28	89	Parameters Changed Using the Boiler Type Parameter Selections
Section XIII - Repair Parts		
N/A	Pages 116 through 127	

LIMITED WARRANTY FOR APEX COMMERCIAL GRADE BOILERS

Stainless Steel Heat Exchangers and Parts/Accessories

Subject to the terms and conditions set forth below, Thermal Solutions, Lancaster, Pennsylvania hereby extends the following limited warranties to the original owner of a commercial grade water boiler or Thermal Solutions supplied parts and/or accessories manufactured and shipped on or after January 1, 2014:

ONE YEAR LIMITED WARRANTY ON COMMERCIAL GRADE BOILERS AND PARTS / ACCESSORIES SUPPLIED BY THERMAL SOLUTIONS. Thermal Solutions warrants to the original owner that its commercial grade stainless steel water boilers and parts/accessories comply at the time of manufacture with recognized hydronic industry standards and requirements then in effect and will be free of defects in material and workmanship under normal usage for a period of one year from the date of original installation. If any part of a commercial grade boiler or any part or accessory provided by Thermal Solutions is found to be defective in material or workmanship during this one year period, Thermal Solutions will, at its option, repair or replace the defective part (not including labor).

HEAT EXCHANGER WARRANTIES

Thermal Solutions warrants to the original owner that the heat exchanger of its commercial grade stainless steel boilers will remain free from defects in material and workmanship under normal usage for the time period specified in the chart below to the original owner at the original place of installation. If a claim is made under this warranty during the "No Charge" period from the date of original installation, Thermal Solutions will, at its option, repair or replace the heat exchanger (not including labor). If a claim is made under this warranty after the expiration of the "No Charge" period from the date of original installation, Thermal Solutions will, at its option and upon payment of the pro-rated service charge set forth below, repair or replace the heat exchanger. The service charge applicable to a heat exchanger warranty claim is based upon the number of years the heat exchanger has been in service and will be determined as a percentage of the retail price of the heat exchanger model involved at the time the warranty claim is made as follows:

NOTE: If the heat exchanger involved is no longer available due to product obsolescence or redesign, the value used to establish the retail price will be the published price as set forth in Thermal Solutions Repair Parts Pricing where the heat exchanger last appeared or the current retail price of the then nearest equivalent heat exchanger, whichever is greater.

		Service Charge as a % of Retail Price										
Years of Service		1	2	3	4	5	6	7	8	9	10+	
Stainless Steel		No Charge					20	40	60	80	100	

ADDITIONAL TERMS AND CONDITIONS

1. **Applicability:** The limited warranties set forth above are extended only to the original owner at the original place of installation within the United States and Canada. These warranties are applicable only to boilers, parts, or accessories designated as commercial grade by Thermal Solutions and installed and used exclusively for purposes of commercial space heating or domestic hot water generation through a heat exchanger (or a combination for such purposes) and do not apply to residential grade products or industrial uses.
2. **Components Manufactured by Others:** Upon expiration of the one year limited warranty on commercial grade boilers, all boiler components other than heat exchangers manufactured by others but furnished by Thermal Solutions (such as circulator and controls) will be subject only to the manufacturer's warranty, if any.
3. **Proper Installation:** The warranties extended by Thermal Solutions are conditioned upon the installation of the commercial grade boiler, parts, and accessories in strict compliance with Thermal Solutions installation instructions. Thermal Solutions specifically disclaims liability of any kind caused by or relating to improper installation.
4. **Proper Use and Maintenance:** The warranties extended by Thermal Solutions conditioned upon the use of the commercial grade boiler, parts, and accessories for its intended purposes and its maintenance accordance with Thermal Solutions recommendations and hydronics industry standards. For proper installation, use, and maintenance, see all applicable sections of the Installation and Operating, and Service Instructions Manual furnished with the unit.
5. This warranty does not cover the following:
 - a. Expenses for removal or reinstallation. The owner will be responsible for the cost of removing and reinstalling the alleged defective part or its replacement and all labor and material connected therewith, and transportation to and from Thermal Solutions.
 - b. Components that are part of the heating system but were not furnished by Thermal Solutions as part of the commercial boiler.
 - c. Improper burner set-up or adjustment, control settings, care or maintenance.
 - d. This warranty cannot be considered as a guarantee of workmanship of an installer connected with the installation of the Thermal Solutions boiler, or as imposing on Thermal Solutions liability of any nature for unsatisfactory performance as a result of faulty workmanship in the installation, which liability is expressly disclaimed.
 - e. Boilers, parts, or accessories installed outside the 48 contiguous United States, the State of Alaska and Canada.
 - f. Damage to the boiler and/or property due to installation or operation of the boiler that is not in accordance with the boiler installation and operating instruction manual.
 - i. Any damage or failure of the boiler resulting from hard water, scale buildup or corrosion the heat exchanger. Any damage caused by improper fuels, fuel additives or contaminated combustion air that may cause fireside corrosion and/or c logging of the burner or heat exchanger.
 - j. Any damage resulting from combustion air contaminated with particulate which cause clogging of the burner or combustion chamber including but not limited to sheetrock or plasterboard particles, dirt, and dust particulate. Any damage, defects or malfunctions resulting from improper operation, maintenance, misuse, abuse, accident, negligence including but not limited to operation with insufficient water flow, improper water level, improper water chemistry, or damage from freezing.
 - k. Any damage caused by water side clogging due to dirty systems, corrosion products from the system, or improperly maintained water conditions.